



**STONEGATE 5.3**

# **SMC REFERENCE GUIDE**

STONEGATE MANAGEMENT CENTER

**STONESOFT**

Secure Information Flow

# Legal Information

## End-User License Agreement

The use of the products described in these materials is subject to the then current end-user license agreement, which can be found at the Stonesoft website:

[www.stonesoft.com/en/support/eula.html](http://www.stonesoft.com/en/support/eula.html)

## Third Party Licenses

The StoneGate software includes several open source or third-party software packages. The appropriate software licensing information for those products at the Stonesoft website:

[www.stonesoft.com/en/support/third\\_party\\_licenses.html](http://www.stonesoft.com/en/support/third_party_licenses.html)

## U.S. Government Acquisitions

If Licensee is acquiring the Software, including accompanying documentation on behalf of the U.S. Government, the following provisions apply. If the Software is supplied to the Department of Defense ("DoD"), the Software is subject to "Restricted Rights", as that term is defined in the DOD Supplement to the Federal Acquisition Regulations ("DFAR") in paragraph 252.227-7013(c) (1). If the Software is supplied to any unit or agency of the United States Government other than DOD, the Government's rights in the Software will be as defined in paragraph 52.227-19(c) (2) of the Federal Acquisition Regulations ("FAR"). Use, duplication, reproduction or disclosure by the Government is subject to such restrictions or successor provisions.

## Product Export Restrictions

The products described in this document are subject to export control under the laws of Finland and the European Council Regulation (EC) N:o 1334/2000 of 22 June 2000 setting up a Community regime for the control of exports of dual-use items and technology (as amended). Thus, the export of this Stonesoft software in any manner is restricted and requires a license by the relevant authorities.

## General Terms and Conditions of Support and Maintenance Services

The support and maintenance services for the products described in these materials are provided pursuant to the general terms for support and maintenance services and the related service description, which can be found at the Stonesoft website:

[www.stonesoft.com/en/support/view\\_support\\_offering/terms/](http://www.stonesoft.com/en/support/view_support_offering/terms/)

## Replacement Service

The instructions for replacement service can be found at the Stonesoft website:

[www.stonesoft.com/en/support/view\\_support\\_offering/return\\_material\\_authorization/](http://www.stonesoft.com/en/support/view_support_offering/return_material_authorization/)

## Hardware Warranty

The appliances described in these materials have a limited hardware warranty. The terms of the hardware warranty can be found at the Stonesoft website:

[www.stonesoft.com/en/support/view\\_support\\_offering/warranty\\_service/](http://www.stonesoft.com/en/support/view_support_offering/warranty_service/)

## Trademarks and Patents

The products described in these materials are protected by one or more of the following European and US patents: European Patent Nos. 1065844, 1189410, 1231538, 1259028, 1271283, 1289183, 1289202, 1304849, 1313290, 1326393, 1379046, 1330095, 131711, 1317937 and 1443729 and US Patent Nos. 6,650,621; 6,856,621; 6,885,633; 6,912,200; 6,996,573; 7,099,284; 7,127,739; 7,130,266; 7,130,305; 7,146,421; 7,162,737; 7,234,166; 7,260,843; 7,280,540; 7,302,480; 7,386,525; 7,406,534; 7,461,401; 7,721,084; and 7,739,727 and may be protected by other EU, US, or other patents, or pending applications. Stonesoft, the Stonesoft logo and StoneGate, are all trademarks or registered trademarks of Stonesoft Corporation. All other trademarks or registered trademarks are property of their respective owners.

## Disclaimer

Although every precaution has been taken to prepare these materials, THESE MATERIALS ARE PROVIDED "AS-IS" and Stonesoft makes no warranty to the correctness of information and assumes no responsibility for errors, omissions, or resulting damages from the use of the information contained herein. All IP addresses in these materials were chosen at random and are used for illustrative purposes only.

Copyright © 2011 Stonesoft Corporation. All rights reserved. All specifications are subject to change.

# TABLE OF CONTENTS

## INTRODUCTION

---

### CHAPTER 1

<b>Using StoneGate Documentation</b> . . . . .	9
How to Use This Guide . . . . .	10
Typographical Conventions . . . . .	10
Documentation Available . . . . .	11
Product Documentation . . . . .	11
Support Documentation . . . . .	11
System Requirements . . . . .	12
Supported Features . . . . .	12
Contact Information . . . . .	12
Licensing Issues . . . . .	12
Technical Support . . . . .	12
Your Comments . . . . .	12
Other Queries . . . . .	12

### CHAPTER 2

<b>Introduction to the Management Center</b> . . . . .	13
The StoneGate Security Platform . . . . .	14
StoneGate Components . . . . .	15
Management Clients . . . . .	16
Management Server . . . . .	16
Log Server . . . . .	16
Web Portal Server . . . . .	16
Authentication Server . . . . .	17
Main Benefits of the Management Center . . . . .	17
Centralized Remote Management . . . . .	17
Support for Large-Scale Installations . . . . .	18
High Availability . . . . .	18
Managing Licenses . . . . .	18

### CHAPTER 3

<b>Management Center Deployment</b> . . . . .	19
Overview to Management Center Deployment . . . . .	20
Supported Platforms . . . . .	20
General Deployment Guidelines . . . . .	20
Security Considerations . . . . .	20
Positioning the Management Server . . . . .	21
Positioning Log Servers . . . . .	21
Positioning Management Clients . . . . .	21
Example Deployment Scenario . . . . .	22

## CONFIGURATION TOOLS

---

### CHAPTER 4

<b>Management Client Basics</b> . . . . .	25
Introduction . . . . .	26
System Monitoring Tools . . . . .	26
The Domain Overview . . . . .	26
The System Status View . . . . .	27
The Info Panel . . . . .	28
Overviews . . . . .	28
The Logs View . . . . .	29
Reports . . . . .	30
Configuration Views . . . . .	30
The Policy Editing View . . . . .	31

### CHAPTER 5

<b>Introduction to StoneGate Elements</b> . . . . .	33
Introduction to Elements . . . . .	34
Administration . . . . .	34
Firewall Configuration . . . . .	35
IPS Configuration . . . . .	37
User Authentication Configuration . . . . .	38
Monitoring . . . . .	39
Network Elements . . . . .	40
Services . . . . .	41
Situations . . . . .	41
VPN Configuration . . . . .	43

### CHAPTER 6

<b>Expressions</b> . . . . .	45
Introduction to Expressions . . . . .	46
Operands . . . . .	46
Negation . . . . .	46
Intersection . . . . .	47
Union . . . . .	47
Expression Processing Order . . . . .	48
Grouping Operands Using Parenthesis . . . . .	48
Nesting Expressions . . . . .	49

## ADMINISTRATION TOOLS

---

### CHAPTER 7

<b>Administrator Accounts</b> . . . . .	53
Overview to Administrator Accounts . . . . .	54
Configuration of Administrator Accounts . . . . .	54

Default Elements . . . . .	55
Configuration Workflow . . . . .	56
Task 1: Create a New Administrator Role . . . . .	56
Task 2: Create a New Access Control List . . . . .	56
Task 4: Create a New Administrator Element . . . . .	56
Using Administrator Accounts . . . . .	57
Creating Web Portal User Accounts . . . . .	57
Using External Authentication for Administrators . . . . .	58
Customizing Log Color Settings . . . . .	58
Configuring the Administrator Password Policy . . . . .	59
<b>CHAPTER 8</b>	
<b>Domains . . . . .</b>	<b>61</b>
Overview to Domains . . . . .	62
Configuration of Domains . . . . .	62
Configuration Workflow . . . . .	62
Task 1: Create Domains . . . . .	62
Task 2: Associate Elements with Domains . . . . .	63
Task 3: Define the Administrator Permissions for the Domains . . . . .	63
Examples of Domains . . . . .	64
Creating Separate Domains for Different Customers . . . . .	64
Creating Separate Domains for Different Sites . . . . .	65
<b>CHAPTER 9</b>	
<b>Categories . . . . .</b>	<b>67</b>
Overview to Categories . . . . .	68
Configuration of Categories . . . . .	68
Default Elements . . . . .	68
Configuration Workflow . . . . .	68
Task 1: Create Categories . . . . .	68
Task 2: Associate Elements with Categories . . . . .	68
Task 3: Select a Category to Filter the Displayed Elements . . . . .	68
Examples of Categories . . . . .	69
Creating Separate Categories for a Firewall and an IPS Configuration . . . . .	69
Combining Categories . . . . .	69

## LOGS, ALERTS, AND REPORTS

---

<b>CHAPTER 10</b>	
<b>Filters . . . . .</b>	<b>73</b>
Overview to Filters . . . . .	74
Configuration of Filters . . . . .	74

Default Elements . . . . .	75
Configuration Workflow . . . . .	75
Task 1: Create a New Filter . . . . .	75
Task 2: Add Fields . . . . .	75
Task 3: Add Operations . . . . .	76
Task 4: Add Values to the Fields . . . . .	77
Task 5: Define Handling of Missing Values . . . . .	77
Task 6: Organize the Filters . . . . .	79
Examples of Filters . . . . .	80
Creating a Filter for Logs Concerning Authenticated Users . . . . .	80
Creating a Filter for Pings in a Network Excluding a Host . . . . .	80

<b>CHAPTER 11</b>	
<b>Log Management . . . . .</b>	<b>81</b>
Overview to Log Management . . . . .	82
Log Entries . . . . .	82
Alert Entries . . . . .	82
Audit Entries . . . . .	82
Domain Boundaries . . . . .	82
Configuration of Log Management . . . . .	83
Configuration Workflow . . . . .	84
Task 1: Define Logging Options . . . . .	84
Task 2: Define Log Tasks . . . . .	84
Task 3: Configure Log Pruning . . . . .	84
Using Log Management Tools . . . . .	85
About the Log Files . . . . .	85
Archive Directories . . . . .	85
Exporting Log Data to Syslog Servers . . . . .	85
Examples of Log Management . . . . .	86
Archiving Old Logs . . . . .	86
Filtering Out Irrelevant Logs . . . . .	86

<b>CHAPTER 12</b>	
<b>Alert Escalation . . . . .</b>	<b>89</b>
Overview to Alert Escalation . . . . .	90
Configuration of Alert Escalation . . . . .	90
Default Elements . . . . .	91
Configuration Workflow . . . . .	91
Task 1: Define Custom Alerts . . . . .	91
Task 2: Define Alert Chains . . . . .	91
Task 3: Define Alert Policies . . . . .	92
Task 4: Configure Alert Channels . . . . .	93
Using Alert Escalation . . . . .	93
Acknowledging Alerts . . . . .	93
Information Included in Alert Notifications . . . . .	94
Designing Alert Policies and Alert Chains . . . . .	94

Using a Custom Script for Alert Escalation . . .	94
Examples of Alert Escalation . . . . .	96
Disabling All Alert Escalation for a Specific Situation . . . . .	96
Escalating Alerts Based on Responsibilities . .	96
<b>CHAPTER 13</b>	
<b>Reports</b> . . . . .	99
Overview to Reports . . . . .	100
Configuration of Reports . . . . .	100
Filtering Data in Reporting. . . . .	101
Section Types. . . . .	102
Configuration Workflow . . . . .	103
Task 1: Create a New Report Design . . . . .	103
Task 2: Add a New Report Section . . . . .	103
Task 3: Add Items to the Section . . . . .	103
Using Reporting Tools . . . . .	104
Generating Reports . . . . .	104
Using the System Report . . . . .	105
Exporting Reports. . . . .	105
Tab-Delimited Text Report Files . . . . .	105
Post-Processing Report Files . . . . .	106
Examples of Reports. . . . .	107
Pinpointing a Disruptive Internal User. . . . .	107
<b>CHAPTER 14</b>	
<b>Incident Cases</b> . . . . .	109
Overview to Incident Cases . . . . .	110
Configuration of Incident Cases . . . . .	110
Configuration Workflow . . . . .	110
Task 1: Create an Incident Case . . . . .	110
Task 2: Set the Management Client to Incident Handling Mode . . . . .	111
Task 3: Attach Data . . . . .	111
Task 4: Attach Players . . . . .	111
Task 5: Write Journal Entries. . . . .	111
Task 6: Close the Incident Case . . . . .	111
Examples of Incident Cases . . . . .	112
Investigation by More Than One Administrator. . . . .	112
Investigation of a False Positive . . . . .	112
Investigation of Suspected Backdoor Traffic . .	112

## APPENDICES

---

<b>APPENDIX A</b>	
<b>Default Communication Ports</b> . . . . .	115
Management Center Ports. . . . .	116
Firewall/VPN Engine Ports . . . . .	118
IPS Engine Ports. . . . .	122

<b>APPENDIX B</b>	
<b>Command Line Tools</b> . . . . .	125
Management Center Commands . . . . .	126
Engine Commands . . . . .	135
Server Pool Monitoring Agent Commands. . . . .	141
<b>APPENDIX C</b>	
<b>Predefined Aliases</b> . . . . .	143
Pre-Defined User Aliases . . . . .	144
System Aliases . . . . .	144
<b>APPENDIX D</b>	
<b>Log Fields</b> . . . . .	147
Log Entry Fields . . . . .	148
Non-exportable Log Entry Fields . . . . .	148
Exportable Alert Log Entry Fields . . . . .	152
Exportable Alert Trace Log Entry Fields . . . . .	152
Exportable Audit Log Entry Fields . . . . .	153
Exportable Firewall Log Entry Fields. . . . .	154
Exportable IPS Log Entry Fields. . . . .	156
Exportable IPS Recording Log Entry Fields . . .	168
Exportable SSL VPN Log Entry Fields. . . . .	169
Facility Field Values . . . . .	169
Type Field Values . . . . .	171
Action Field Values. . . . .	172
Event Field Values . . . . .	172
IPsec VPN Log Messages . . . . .	177
VPN Notifications . . . . .	177
VPN Errors. . . . .	179
VPN Error Codes . . . . .	181
Audit Entry Types . . . . .	182
Syslog Entries . . . . .	187
Log Fields Controlled by the Additional Payload Option. . . . .	187
Connection States . . . . .	188
<b>APPENDIX E</b>	
<b>Schema Updates for External LDAP Servers</b> . . .	191
<b>Glossary</b> . . . . .	193
<b>Index</b> . . . . .	223



# INTRODUCTION

---

## **In this section:**

**[Using StoneGate Documentation](#) - 9**

**[Introduction to the Management Center](#) - 13**

**[Management Center Deployment](#) - 19**



## CHAPTER 1

# USING STONEGATE DOCUMENTATION

Welcome to StoneGate™ High Availability Firewall/VPN solution by Stonesoft Corporation. This chapter describes how to use this Guide and related documentation. It also provides directions for obtaining technical support and giving feedback about the documentation.

The following sections are included:

- ▶ [How to Use This Guide](#) (page 10)
- ▶ [Documentation Available](#) (page 11)
- ▶ [Contact Information](#) (page 12)

# How to Use This Guide

This *Reference Guide* provides information that helps administrators of StoneGate installations to understand the system and its features. This guide provides high-level descriptions and examples of the configuration workflows.

The chapters in the first section provide a general introduction to the StoneGate Management Center. The sections that follow each include the chapters related to one feature area. The last section provides detailed reference information in tabular form.

For other available documentation, see [Documentation Available](#) (page 11).

## Typographical Conventions

The following conventions are used throughout the documentation:

**Table 1.1** Typographical Conventions

Formatting	Informative Uses
<b>User interface text</b>	Text you see in the User Interface (buttons, menus, etc.) and any other interaction with the user interface are in <b>bold-face</b> .
<i>References, terms</i>	Cross-references and first use of acronyms and terms are in <i>italics</i> .
Command line	File names, directories, and text displayed on the screen are monospaced.
<b>User input</b>	User input on screen is in <b>monospaced bold-face</b> .
<i>Command parameters</i>	Command parameter names are in <i>monospaced italics</i> .

We use the following ways to indicate important or additional information:



**Note** – Notes prevent commonly-made mistakes by pointing out important points.



**Caution** – Cautions prevent breaches of security, information loss, or system downtime. Cautions always contain critical information that you must observe.

**Tip** – Tips provide additional helpful information, such as alternative ways to complete steps.

**Example** Examples present a concrete scenario that clarifies the points made in the adjacent text.

# Documentation Available

---

StoneGate technical documentation is divided into two main categories: [Product Documentation](#) and [Support Documentation](#). Each StoneGate product has a separate set of manuals.

## Product Documentation

The table below lists the available product documentation. PDF guides are available on the Management Center CD-ROM and at <http://www.stonesoft.com/support/>.

Table 1.2 Product Documentation

Guide	Description
Reference Guide	Explains the operation and features of StoneGate comprehensively. Demonstrates the general workflow and provides example scenarios for each feature area. Available for StoneGate Management Center, Firewall/VPN, and StoneGate IPS.
Installation Guide	Instructions for planning, installing, and upgrading a StoneGate system. Available for StoneGate Management Center, Firewall/VPN, and IPS.
Online Help	Describes how to configure and manage the system step-by-step. Accessible through the Help menu and by using the Help button or the F1 key in any window or dialog. Available in the StoneGate Management Client and the StoneGate Web Portal. An HTML-based system is available in the StoneGate SSL VPN Administrator through help links and icons.
Administrator's Guide	Describes how to configure and manage the system step-by-step. Available as a combined guide for both StoneGate Firewall/VPN and StoneGate IPS, and as separate guides for StoneGate SSL VPN and StoneGate IPsec VPN Client.
User's Guide	Instructions for end-users. Available for the StoneGate IPsec VPN Client and the StoneGate Web Portal.
Appliance Installation Guide	Instructions for physically installing and maintaining StoneGate appliances (rack mounting, cabling, etc.). Available for all StoneGate hardware appliances.

## Support Documentation

The StoneGate support documentation provides additional and late-breaking technical information. These technical documents support the StoneGate Guide books, for example, by giving further examples on specific configuration scenarios.

The latest StoneGate technical documentation is available on the Stonesoft website at <http://www.stonesoft.com/support/>.

## System Requirements

The system requirements for running the StoneGate Management Center can be found in the Management Center [Release Notes](#) available at the Stonesoft Support Documentation pages.

## Supported Features

Not all StoneGate features are supported on all platforms. See the [Appliance Software Support Table](#) at the Stonesoft Support Documentation pages for more information.

## Contact Information

---

For street addresses, phone numbers, and general information about StoneGate and Stonesoft Corporation, visit our website at <http://www.stonesoft.com/>.

## Licensing Issues

You can view your current licenses at the License Center section of the Stonesoft website at <https://my.stonesoft.com/managelicense.do>.

For license-related queries, e-mail [order@stonesoft.com](mailto:order@stonesoft.com).

## Technical Support

Stonesoft offers global technical support services for Stonesoft's product families. For more information on technical support, visit the Support section at the Stonesoft website at <http://www.stonesoft.com/support/>.

## Your Comments

We want to make our products fulfill your needs as well as possible. We are always pleased to receive any suggestions you may have for improvements.

- To comment on software and hardware products, e-mail [feedback@stonesoft.com](mailto:feedback@stonesoft.com).
- To comment on the documentation, e-mail [documentation@stonesoft.com](mailto:documentation@stonesoft.com).

## Other Queries

For queries regarding other matters, e-mail [info@stonesoft.com](mailto:info@stonesoft.com).

## CHAPTER 2

# INTRODUCTION TO THE MANAGEMENT CENTER

This chapter describes the StoneGate Management Center components and provides you an overview to this centralized management system's main benefits. This chapter also explains the basics of licensing your StoneGate system components.

The following sections are included:

- ▶ [The StoneGate Security Platform](#) (page 14)
- ▶ [StoneGate Components](#) (page 15)
- ▶ [Main Benefits of the Management Center](#) (page 17)
- ▶ [Managing Licenses](#) (page 18)

# The StoneGate Security Platform

---

The StoneGate Management Center (SMC) forms the core of the StoneGate security platform. The Management Center makes StoneGate especially well-suited to complex and distributed network environments. The Management Center configures and monitors all the components in the StoneGate Firewall/VPN and IPS systems.

The centralized management system provides a single point of contact for a large number of geographically dispersed administrators. The unified management platform provides major benefits for organizations of all sizes:

- Interaction between the firewall and IPS components in the same system creates real security benefits by allowing automatic coordinated responses when a security threat is detected, providing instant blocking of unwanted traffic, and reducing the need for immediate human intervention.
- Multiple administrators can log in at the same time to efficiently configure and monitor all StoneGate components. The system provides a single user interface that allows unified configuration, monitoring, and reporting of the whole StoneGate security platform with the same tools and within the same user session.
- The reuse of configuration information across components in the system allows you to avoid the laborious and error-prone duplicate work of configuring the same details for all components individually or exporting and importing the configurations between multiple separate systems.

The management system is designed to manage large installations and to be geographically distributed, so it is flexible and allows scaling up the existing components and adding new types of components to the system without sacrificing its ease-of-use.

# StoneGate Components

The StoneGate system components and their roles are illustrated below.

Illustration 2.1 StoneGate System Components

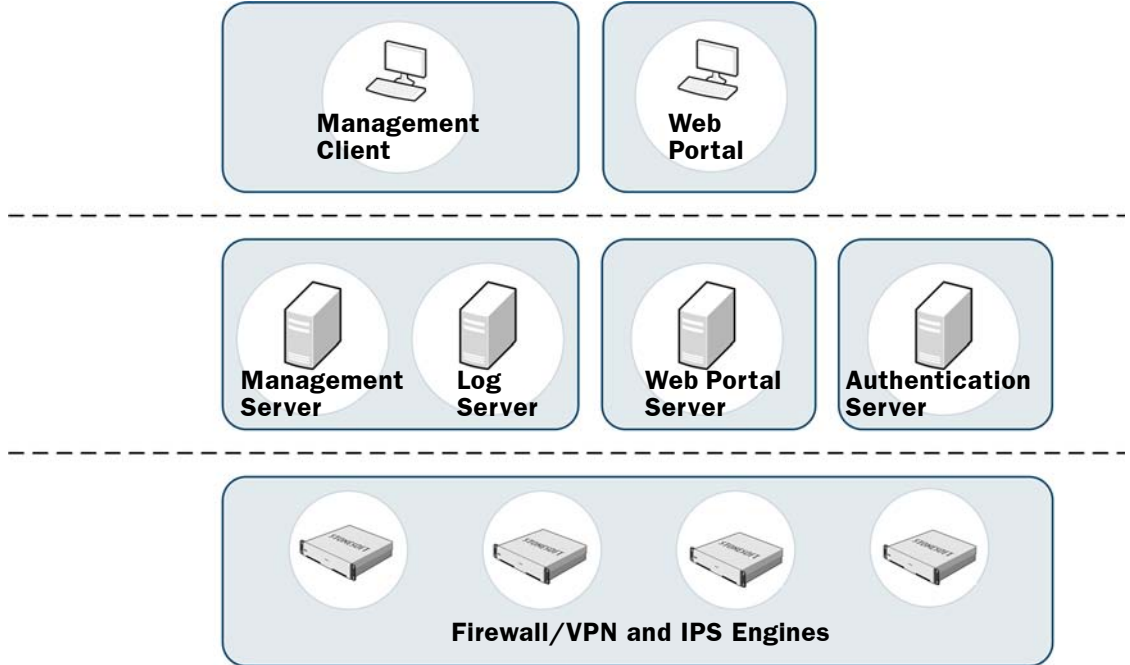

StoneGate's distributed architecture allows deploying the system components effectively in different network environments. You can flexibly add, remove, and reposition StoneGate system components according to your needs. One StoneGate Management Center can manage a large number of security engines.

The different components are described in [Table 2.1](#).

Table 2.1 StoneGate System Components

Component	Description
Management Clients	Provide a user interface for configuring, controlling, and monitoring the system. Connects to the Management Server.
Management Servers	Store all configuration data and relay commands to the engines.
Log Servers	Store logs and perform alert escalation.
Web Portal Servers	Provide restricted viewing of configuration information, reports, and logs.
Authentication Servers	Provide user linking and user authentication services for end-user and administrator authentication.
Engines	Inspect and filter the traffic.

All communications between system components are authenticated and encrypted. The traffic inspection engines work independently according to their installed configuration, so even if the connections to the Management Center are cut, traffic inspection continues without interruption.

## Management Clients

The Management Client is the tool for all day-to-day configuration and management tasks, including network interface configuration and remote upgrades. All commands and configuration changes are relayed through the Management Server, so the Management Clients never connect to the security engines directly. Management Clients also connect to Log Servers to fetch log entries for administrators to view. A large number of Management Clients can be deployed anywhere in the network.

## Management Server

The Management Server is the central component for system administration. One Management Server can manage a large number of different types of StoneGate security engines. The Management Server provides the following types of services:

- Administration and system commands: the Management Server is the central point of all administration tasks (accessed through the Management Client).
- Configuration database: the Management Server stores all configuration information for Firewall/VPN and IPS engines and other system components.
- Monitoring: the Management Server keeps track of the operating state of the system components and relays this information to the administrators.
- Certificate authorities (CAs): the Management Server installation includes two basic CAs: an Internal CA that issues all certificates that system components need for system communications, and a VPN CA that can be used to issue certificates for VPN authentication.

## Log Server

Multiple Log Servers can be deployed, which is particularly useful in geographically distributed systems. Log Servers provide the following types of services:

- Log data: Log Servers receive and store logs from other system components and make the data available for viewing and generating reports.
- Statistics and status data: Log Servers receive, relay, and store information about the operation of other system components and keep a record available for generating reports.
- Alert notifications: Log Servers can notify administrators about new alerts in the system, for example, by sending out an e-mail or an SMS text message.

## Web Portal Server

The Web Portal Server is an optional component (separate license required) that can be used to provide restricted access to log data, reports, and policy snapshots. The Web Portal Server provides a Web-based interface that users who have Web Portal user accounts can access with their Web browsers.

## Authentication Server

The Authentication Server is an optional component (separate license required) that can be used to provide user authentication services for end-user and administrator authentication. You must link users from an external directory server to the Authentication Server's internal user database if you want to authenticate users with the authentication methods offered by the Authentication Server. The Authentication Server license defines the maximum number of named users for user linking in the Authentication Server's user database. See the *StoneGate Firewall Reference Guide* for more information about directory services and user authentication.

The Authentication Server can be installed as a single Authentication Server or as a clustered pair of Authentication Servers. Only one single Authentication Server can be installed in each StoneGate system.

Additionally, the Authentication Server can provide user authentication services for StoneGate SSL VPN, and for third-party components. Each component that uses the authentication services provided by the Authentication Server must be defined as a RADIUS client in the Authentication Server properties. The Management Server and firewalls with static IP addresses are automatically defined as RADIUS clients of the Authentication Server. The Authentication Server license defines the maximum number of RADIUS clients (excluding other StoneGate components).

## Main Benefits of the Management Center

---

### Centralized Remote Management

A centralized point for managing all firewall, IPS, and VPN components simplifies the system administration significantly and allows combining information from different sources without having to integrate the components with an external system. The centralized management system is not an add-on in StoneGate, but the system has been designed from the start to be centrally managed.

The main centralized management features in StoneGate include the following:

- Sharing of configuration data in different configurations eliminates the need for duplicate work, which reduces the complexity of configurations and the amount of work required for making changes. For example, an IP address used in the configurations of several different security engines has to be changed only once in one place because it is defined as a reusable element in the system.
- Remote upgrades can be downloaded and pushed automatically to several components. A single remote upgrade operation updates all necessary details on the security engines, including operating system patches and updates.
- Fail-safe policy installation with automatic rollback to prevent policies that prevent management connections from being installed.
- The integrated backup feature allows saving all system configurations stored on the Management Server in one manually or automatically run backup.
- Central access point for administrators with centralized access control. The Management Client requires no separate installation, because it can be made available centrally and be launched through a Web browser. Several administrators can be logged in at the same time and simultaneously make changes to the system. Conflicting changes are automatically prevented. Administrator privileges can be easily adjusted in a highly granular way.

## Support for Large-Scale Installations

The StoneGate Management Center is scalable from managing a single security engine up to a system consisting of hundreds of components. Several Log Servers are usually required in larger systems, but a single Management Server can still effectively manage very large installations. The features that are specifically targeted at making large-scale installations easy to manage include the possibility to separate configurations into isolated Domains and to filter configuration definitions in and out of view based on user-defined categorizations.

## High Availability

Optionally, one or more backup Management Servers can be installed (depending on the type of license). A backup Management Server allows controlling the system without delays and without loss of configuration information if the primary Management Server is damaged, loses power, or becomes otherwise unusable.

Log Servers can also be used as backups for each other to allow continued operation when a Log Server is lost. When the primary Log Server becomes unavailable, engines can automatically start sending new logs and monitoring data to a pre-selected second Log Server. Log Servers do not automatically synchronize their data, but you can set up automatic tasks in the system for backing up important records.

## Managing Licenses

---

The Management Server maintains the license files, which provide your system a proof of purchase. You receive your licenses as POL (proof of license) codes from Stonesoft in a license delivery pack that is delivered via e-mail. The license code for StoneGate appliances is printed on a sticker attached to the appliances (the POS code). You can use your license code to log in to Stonesoft's license center accessible through [www.stonesoft.com/en/support/](http://www.stonesoft.com/en/support/) to view and manage the license information.

Generally, each Management Center server and each firewall and IPS engine must be separately licensed in your Management Center.

- The Management Center components must always be licensed by importing a license file that you create at the Stonesoft website.
- Licenses for StoneGate appliances may be generated automatically or you may have to generate also these licenses manually at the Stonesoft website, depending on the appliance model and Management Server connectivity.
- License files for StoneGate SSL VPN appliances can be imported and updated either through the appliances' own local administration console or through the Management Client.

The use of some individual features is also limited by license.

All licenses include a maximum version on which they are valid (licenses are valid on all previous software versions up to the version indicated). Licenses are by default automatically updated to the newest version possible for the component in question. If automatic license updates are not possible or disabled, you must generate new licenses manually before you upgrade to a new major release.

License upgrades are included in maintenance contracts. If the maintenance contract of a component expires, it is not possible to upgrade the license to any newer version. Evaluation licenses are valid for 30 days. Purchased licenses do not expire unless otherwise noted.

## CHAPTER 3

# MANAGEMENT CENTER DEPLOYMENT

This chapter provides general guidelines for the StoneGate Management Center deployment.

The following sections are included:

- ▶ [Overview to Management Center Deployment](#) (page 20)
- ▶ [Security Considerations](#) (page 20)
- ▶ [Positioning the Management Server](#) (page 21)
- ▶ [Positioning Log Servers](#) (page 21)
- ▶ [Positioning Management Clients](#) (page 21)
- ▶ [Example Deployment Scenario](#) (page 22).

# Overview to Management Center Deployment

## Supported Platforms

The StoneGate Management Center (SMC) can be installed on standard Intel-compatible servers. The hardware requirements can be found in the supplementary technical documentation database at Stonesoft's website at <http://www.stonesoft.com/en/support/index.html>. Although also the Web Start distribution of the Management Client is officially certified to run only on the listed official platforms, it has been found to run satisfactorily on other platforms as well (including Mac OS X and additional Linux distributions), providing that the required version of JRE (Java Runtime Environment) is installed.

## General Deployment Guidelines

The basic Management Center installation consists of a Management Server, a Log Server, and Management Clients. It is possible to run the Management Server and the Log Server on the same machine in low-traffic environments. In larger environments, the components are run on dedicated servers. Several Log Servers may be needed in large or geographically distributed organizations. The Management Clients connect to the Management Server for configuring and monitoring the system and to Log Servers for browsing the log entries.

**Table 3.1** General Guidelines for StoneGate Management Center Deployment

System Component	General Guidelines
Management Server	Position on a central site where it is physically accessible to the administrators responsible for maintaining its operation.
Log Servers	Place the Log Servers centrally and/or locally on sites as needed based on log data volume, administrative responsibilities, etc.
Web Portal Server	The Web Portal Server can be deployed in any location that has network access to the Management Server and the Log Servers.
Authentication Server	The Authentication Server can be deployed in any location that has network access to the Management Server and the Log Servers. Nodes belonging to the same Authentication Server can be deployed in separate locations.
Management Clients	Management Clients can be used from any location that has network access to the Management Server and the Log Servers.

## Security Considerations

The information stored in the Management Center is highly valuable to anyone conducting or planning malicious activities in your network. Someone who gains administrator access to the Management Server can alter the configurations to their liking. The most likely way someone could achieve this is by exploiting weaknesses in the operating system or other services running on the same computer to gain administrator privileges in the operating system.



**Caution** – Secure the Management Server computer. **Anyone who has administrator access to the operating system can potentially view and change any StoneGate configurations.**

Consider at least the following points to secure the Management Server and Log Server:

- Prevent any unauthorized access to the servers. Restrict access to the minimum required both physically and with operating system user accounts.
- Take all necessary steps to keep the operating system secure and up to date.
- We recommend that you do not run any non-StoneGate server software on the same computer with the StoneGate servers.
- We recommend that you place the servers in a separate, secure network segment that does not contain any non-StoneGate servers, and that you limit access to this network to specific authenticated users.

## Positioning the Management Server

---

The Management Server is usually positioned on a central site at the corporate headquarters or data center, from where it can reach all other system components. The Management Server does not need to be located close to the administrators, as the Management Clients connect to the Management Server and Log Servers over the network using an encrypted connection.

We recommend that you use the same Management Center to manage all your StoneGate security engines. This unified approach simplifies managing physically distributed network environments and allows closer integration, for example, sending blacklist requests from the IPS components to the firewalls. Also, the configuration information and log data can then be shared and used efficiently together. A single Management Server can manage a very large number of components efficiently. A disaster recovery setup with automatically-synchronized backup Management Servers is available as a separately licensed option.

## Positioning Log Servers

---

Log Servers store engine-generated logs and traffic captures. The transferred amounts of data can be substantial, so the primary concern for Log Server deployment is the number and throughput of the engine components that send data to the Log Server. Several Log Servers can be located both on a central site as well as at remote sites. A single shared Log Server can be sufficient for a number of remote sites with low traffic volumes, whereas a large office with very high volumes of network traffic may require even several Log Servers for efficient use.

Log Servers also handle alerts and alert escalation to inform the administrators on critical events. The alerts can be handled locally on each Log Server, or alternatively the alerts can be forwarded to a different Log Server. For example, all the alerts from different remote sites can be forwarded to a central Log Server at the corporate headquarters for alert escalation.

## Positioning Management Clients

---

The Management Client provides a graphical user interface for managing and monitoring the entire system. Management Clients can be used at any location from which there is access to the Management Server for system administration and the Log Servers for log and alert browsing. The Firewall/VPN and IPS engines are managed through the Management Server, so the Management Client never connects directly to the security engines.

The Management Clients can be installed locally or launched through Java Web Start. The main difference between the installations is that locally installed clients are also upgraded locally and individually, whereas the Web Start installation is updated centrally and the individual Management Client installations are then automatically upgraded without user intervention. Additionally, the local installation is possible only on officially supported Management Center platforms, whereas running the Web Start version is usually possible also on other platforms that have the required version of JRE (Java Runtime Environment) installed.

## Example Deployment Scenario

In this example deployment, a company has operations in three different locations. There are some StoneGate security engines and administrators who are responsible for managing the local equipment at each site.

**Illustration 3.1** Example of a Distributed Management Center Deployment

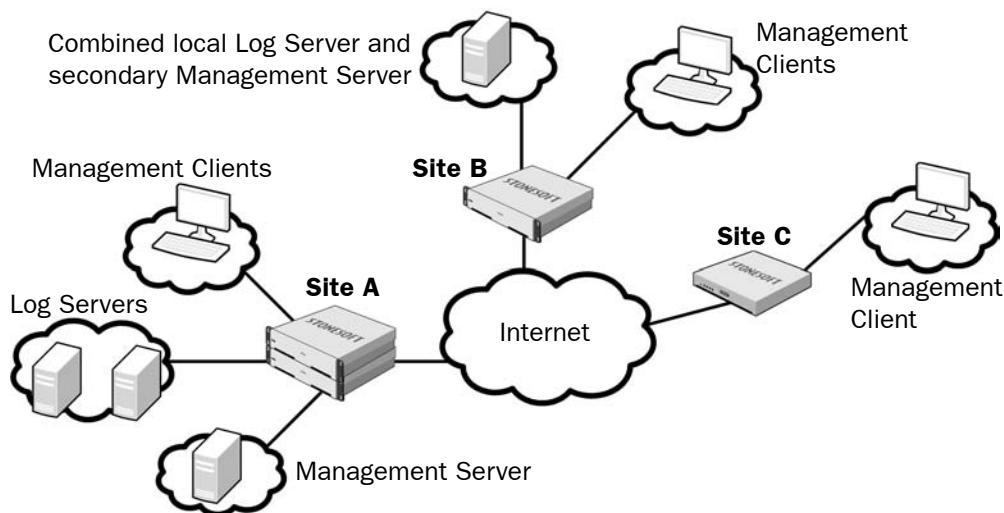

Site A is the main site of the company. The Management Server that manages all local and remote components is located at Site A, since the main administrators responsible for maintaining the server are stationed there. There are also two separate Log Servers at Site A, since there are a high number of security engines at this site, producing a high volume of logs. The Log Servers also work as backup servers for each other.

Site B is a large branch office that is also designated as the disaster recovery site for the main site, although just the most important services are duplicated. This site has a moderate number of security engines. A separate Log Server is installed at Site B to ensure swift log browsing for the local administrators. There is also a Management Server installed on the same server, but it is a secondary server that works as a backup for the Management Server at Site A; the server at Site B is only used for managing the system if there is a major incident at Site A that destroys the infrastructure.

Site C is a small branch office that has only a few security engines. There is a single local administrator who is an infrequent user of StoneGate. There are no Management Center components at Site C; the local security engines send their data to the Log Servers at Site A.

# CONFIGURATION TOOLS

---

## **In this section:**

**Management Client Basics - 25**

**Introduction to StoneGate Elements - 33**

**Expressions - 45**



## CHAPTER 4

# MANAGEMENT CLIENT BASICS

The Management Client is the single graphical tool that is used for setting up, managing, and monitoring all features in the StoneGate system.

The following sections are included:

- ▶ [Introduction](#) (page 26)
- ▶ [System Monitoring Tools](#) (page 26)
- ▶ [Configuration Views](#) (page 30)
- ▶ [The Policy Editing View](#) (page 31)

# Introduction

The Management Client is the tool for configuring, controlling, and monitoring your StoneGate system. The StoneGate Firewall/VPN and StoneGate IPS engines are fully managed through the Management Client. You can also monitor, license, upgrade, and change the operating status of StoneGate SSL VPN engines through the Management Client. Third-party devices can also be monitored through the Management Client.

This chapter gives an general overview to the different view in the Management Client, but does not contained detailed instructions for using the various tools. For detailed steps, see the Management Client's *Online Help* or the *StoneGate Administrator's Guide* PDF.

## System Monitoring Tools

### The Domain Overview

If the configurations are divided in different administrative Domains, the Domain Overview is displayed as the first view after login to administrators who have privileges to several domains. You can then select the Domain that you want to manage. See [Domains](#) (page 61) for more information.

Illustration 4.1 Domain Overviews and Domain Selection

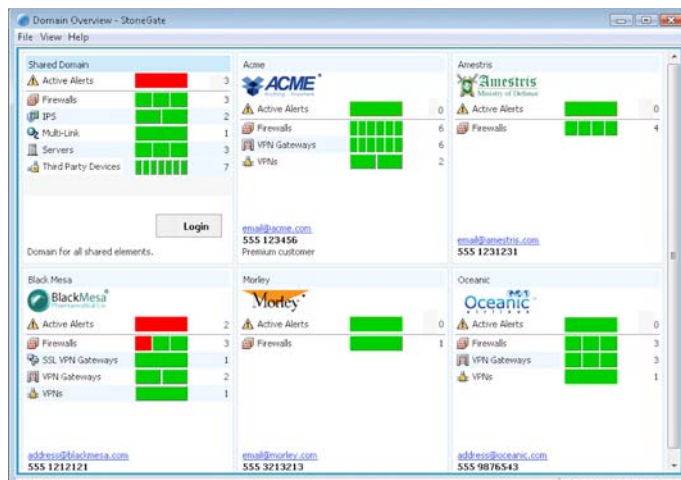

# The System Status View

The System Status view is where you can control and check the health of system components and monitored third party devices. The status information is stored on Log Servers. The Management Server compiles the System Status view based on data from all Log Servers.

Illustration 4.2 System Status View

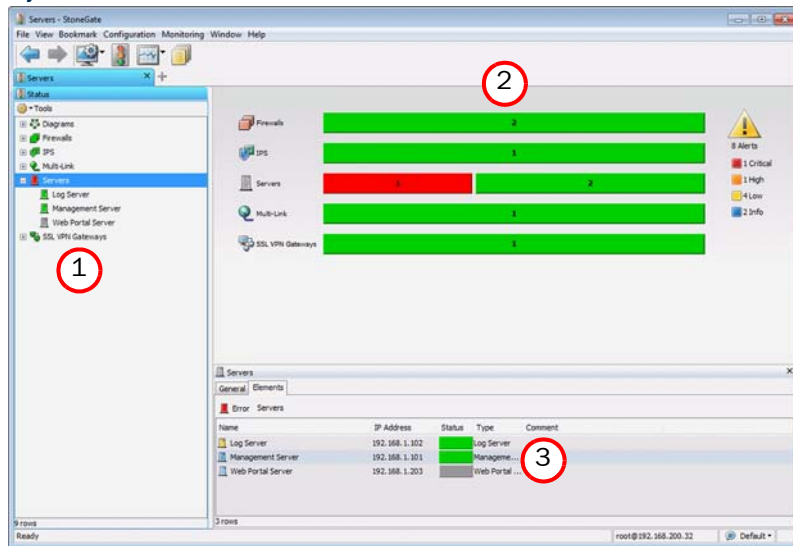

The illustration above shows the main parts of the view:

1. Status Tree
2. System Summary
3. Info Panel

The System Summary shows the status of the entire system at a glance. You can view more details by clicking the displayed status information. The alert summary displayed here refers to Active alerts (alerts that nobody has acknowledged).

The Status tree displays all components in your system that can be monitored, and also those Diagrams and Groups that contain monitored elements. Selecting an element in the Status Tree switches the main view to graphical monitoring.

Illustration 4.3 Graphical Monitoring



The automatic graphical monitoring diagram shows the selected component's status and the status of its connections with other system components.

When you select an individual engine node in the Status tree, the main view switches to hardware monitoring with details on the status of network ports.

Illustration 4.4 Hardware Monitoring



In this view, more detailed information is shown in the Info panel for network interfaces and hardware (appliance) status.

## The Info Panel

The Info panel is shown by default in most views. In addition to element details, the Info panel shows the most important status information regarding system components.

Node status on clusters

Cluster status

Connectivity status with other system components

## Overviews

Overviews are customizable system monitoring views. In addition to status information, you can add various statistics related to the traffic and the operating state of components. You can display information in various ways, such as tables, maps, and different types of charts. Statistics can trigger an alert when the value of a monitored item reaches a limit you set.

Illustration 4.5 Example Overview



# The Logs View

The Logs view can show entries generated by any system components and third-party components that send data to SMC. The logged data includes alert and audit entries (depending on administrator rights). You can filter the display by any combination of details that exist in the records. There are three different arrangements: *Records*, *Details*, and *Statistics*.

The records arrangement allows you to view selected details of many entries at a time. The columns in the table are fully customizable.

Illustration 4.6 Logs View in the Records Arrangement

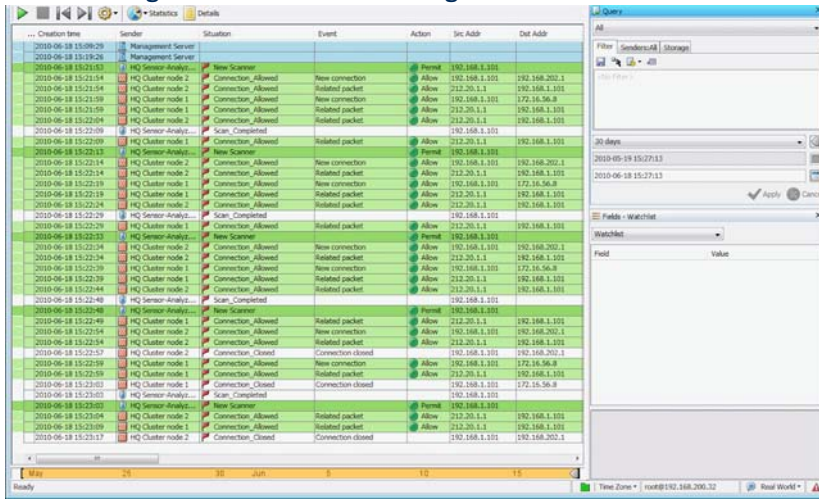

The Details arrangement gives an overview to an individual entry.

Illustration 4.7 Details Arrangement

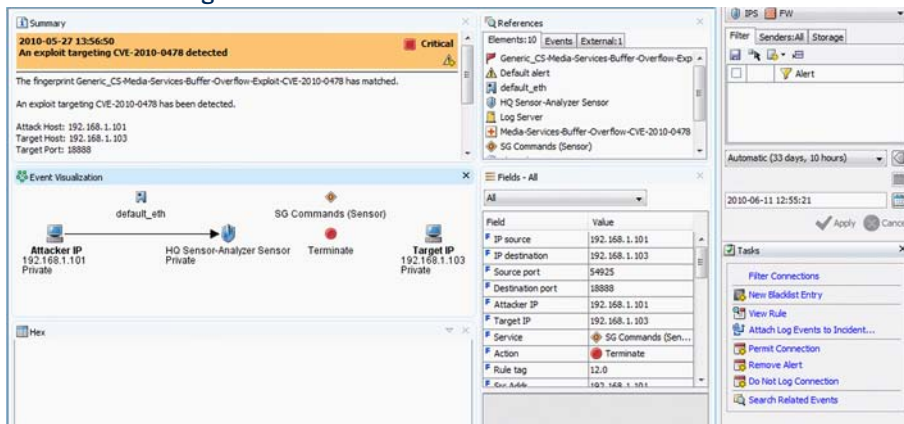

The Statistics arrangement allows you to generate basic summaries of the log data currently displayed in the Logs view similar to the charts in overviews, with a possibility to drill in to the logs through individual chart items.

# Reports

The reporting feature allows you to create statistical summaries based on logs and stored statistical information. The Reports can be viewed in the Management Client or exported automatically or manually. See [Reports](#) (page 99) for more information.

Illustration 4.8 An Example Report

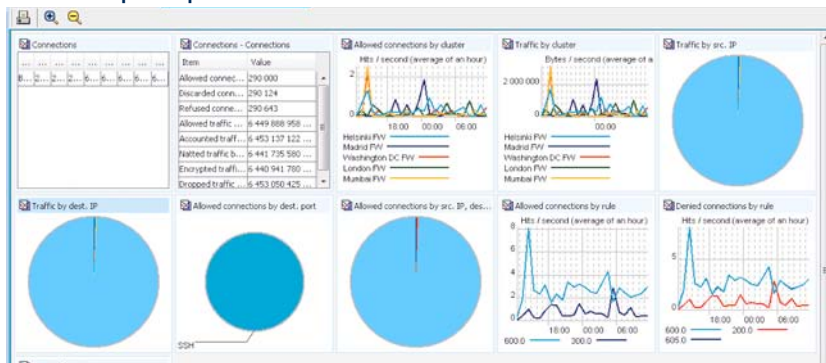

# Configuration Views

Configuration views allow you to view, modify, and add configuration information in the system.

Illustration 4.9 The Administration Configuration Views

Access to Configuration views.

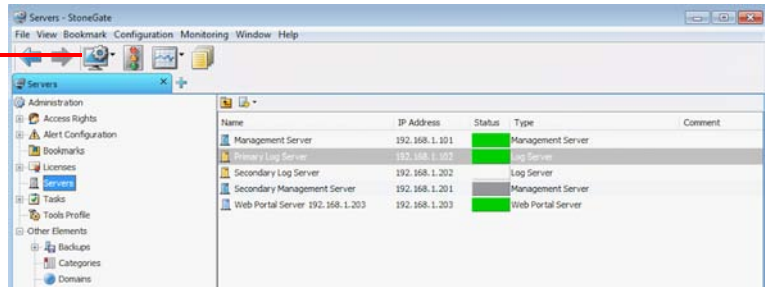

There are different Configuration views for different tasks. In all views, the main level of the tree contains the elements that need to be changed most often. Supporting and less frequently changed elements can be found under the Other Elements branch.

- The Firewall Configuration view allows you to manage Firewall elements, and configure firewall policies.
- The IPS Configuration view allows you to manage IPS elements and configure IPS policies.
- The User Authentication Configuration view allows you to configure user authentication and directory services, and manage user accounts.
- The VPN Configuration view allows you to configure IPsec VPN connections.
- The Administration Configuration view allows you to manage the StoneGate system, including updates, licenses, administrator accounts, alert escalation, etc.
- The Monitoring Configuration view allows you to create statistical reports, diagrams, configure additional monitoring related features (such as third party device monitoring) etc.

See [Introduction to StoneGate Elements](#) (page 33) for more information.

# The Policy Editing View

The instructions for traffic handling are stored as rules in Policy elements. You can open policies in two modes. Any number of administrators can simultaneously check the rules in the *Preview mode*. When you open the policy in the *Edit mode*, the policy is locked for you exclusively.

The Policy Editing View has tabs for the different types of rules in the policy and a side panel for selecting and creating elements that you use in the rules. The policy elements and the different types of rules are discussed in the *Firewall/VPN Reference Guide* and the *IPS Reference Guide*.

Illustration 4.10 Policy Editing View (IPv4 NAT rules in a Firewall Policy)

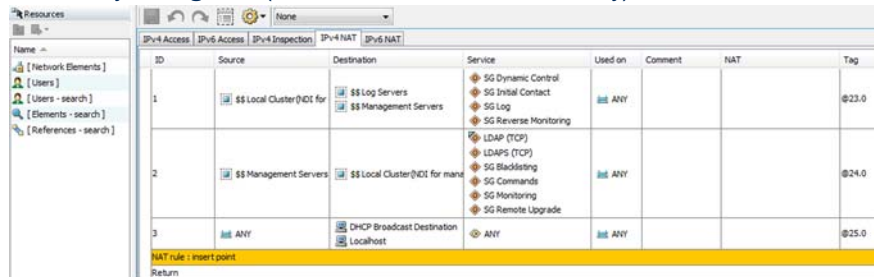



## CHAPTER 5

# INTRODUCTION TO STONEGATE ELEMENTS

The StoneGate Management Center stores configurations as reusable elements. All configuration data you enter into the system is stored in elements of different types.

The following sections are included:

- ▶ [Introduction to Elements](#) (page 34)
- ▶ [Administration](#) (page 34)
- ▶ [Firewall Configuration](#) (page 35)
- ▶ [IPS Configuration](#) (page 37)
- ▶ [User Authentication Configuration](#) (page 38)
- ▶ [Network Elements](#) (page 40)
- ▶ [Services](#) (page 41)
- ▶ [Situations](#) (page 41)
- ▶ [VPN Configuration](#) (page 43)

# Introduction to Elements

Apart from minor exceptions, all StoneGate configurations are created in the Management Client, where information is stored as reusable *elements*. For example, the security engines, traffic inspection policies, IP addresses, log filters, backups, and the licenses for the system components are all displayed as elements.

Different element types are provided for different concepts. The elements in the system define information both for adjusting the traffic inspection policies and for managing the StoneGate system. This chapter gives you a brief description of each type of element in the system. You can open either a full tree of all elements or just one of the task-specific sections through the Management Client's **Configuration** menu. Alternatively, the individual sections can be accessed through the Configuration icon in the main toolbar.

## Administration

The table below lists the types of elements that are used for system administration.

**Table 5.1** Types of Elements For System Administration

Element Type		Explanation
Access Rights	Access Control Lists	Sets of other elements that you can grant to one or more administrator accounts when assigning administrator privileges.
	Administrator Roles	Sets of actions that administrators are allowed to perform both globally and/or specifically on some set of elements.
	Administrators	StoneGate administrator accounts.
	Web Portal Users	User accounts for the StoneGate Web Portal.
Alert Configuration	Alert Chains	Lists of administrators and contact methods for escalating alerts.
	Alert Policies	Rules for choosing which alerts are escalated using which Alert Chain.
	Alert Senders	System components that can send alerts.
	Alerts	Labels for alerts that help in separating different alerts from each other in alert escalation.
	Policy Snapshots	Saved versions of the Log Server configuration. Created each time you install or refresh the Alert Policy on the Log Server.
Bookmarks	User-created shortcuts to views in the Management Client.	
Licenses	The StoneGate components' licenses (proof of purchase).	
Servers	The Management Center servers configured in your system.	
Tasks	System maintenance tasks, task scheduling, and information on running and executed tasks (both tasks launched by users and generated by the system).	

**Table 5.1 Types of Elements For System Administration (Continued)**

Element Type		Explanation
Tools Profiles		User-configured additional commands/tools for components.
Other Elements	Backups	Log Server and Management Server backups.
	Categories	Allow filtering the view in the Management Client to a subset of elements.
	Domains	Enforce separation of configurations based on administrator privileges.
	Engine Upgrades	Packages for remote upgrades that have been manually or automatically imported into the system.
	Geolocations	Used for illustrating the geographical location of IP addresses (for example, in logs and diagrams).
	Internal Certificate Authorities	Management Server's Internal Certificate Authority that issues all certificates that components need for system communications. A new Internal Certificate Authority is automatically generated before the old one expires.
	Internal Certificates	Certificates that are used in communications between the system components.
	Locations	Used for defining contact addresses when NAT (IP address translation) is applied to communications between system components.
	Updates	Dynamic update packages that update Stonesoft-supplied definitions in your installation. Most of the content is Situations (used in deep packet inspection).
Web Portal Localizations	Used for translating the Web Portal between languages.	

## Firewall Configuration

The table below introduces elements used for configuring firewalls. For more information on configuring firewall features, see the *Firewall Reference Guide*.

**Table 5.2 Types of Elements in the Firewall Configuration**

Element Type	Explanation
Firewalls	Configurations particular to individual StoneGate firewall/VPN engines, such as the interface configuration.
Firewall Policies	The rules for inspecting and handling network traffic.
Network Elements	Represent IP addresses. See <a href="#">Network Elements</a> (page 40).

**Table 5.2 Types of Elements in the Firewall Configuration (Continued)**

Element Type		Explanation	
Other Elements	Applications	Provide a way to dynamically identify traffic patterns related to the use of a particular application.	
	HTTPS Inspection Exceptions	Lists of domains that can be used to exclude some traffic from HTTPS decryption and inspection.	
	Policy Snapshots	Saved versions of the firewall configuration. Created each time you install or refresh a policy on a firewall.	
	Protocols	Supported network protocols. Can be used to define new Services for matching traffic in firewall policies. You cannot add, delete, or modify the Protocol elements.	
	QoS Classes	An identifier that can be assigned to network traffic to define QoS policies for the traffic.	
	QoS Policies	Rules for bandwidth use and priorities for the QoS Classes.	
	Services	Network protocols and ports. See <a href="#">Services</a> (page 41).	
	Situations	Patterns that deep inspection looks for in traffic. See <a href="#">Situations</a> (page 41).	
	TLS Matches	Define matching criteria for the use of the TLS (transport layer security) protocol in traffic, and specify whether TLS traffic is decrypted for inspection.	
	Firewall Properties	Anti-Spam	Settings for identifying and blocking e-mail messages as spam.
		Antispoofing	Rules for preventing IP address spoofing.
		HTML Pages Profiles	Define the look of the login page, challenge page, and status page shown to end-users who authenticate through a web browser.
Routing		Rules for routing traffic.	
SNMP Agents		Configuration information for sending SNMP traps to external components about firewall system events.	
User Agents		Represent a software component installed on a Windows server to associate users with IP addresses.	
User Responses		Settings for notifying end-users about different policy actions.	
Certificates		Client Protection Certificate Authorities, Server Protection Credentials, and Trusted Certificate Authorities used in HTTPS inspection.	

# IPS Configuration

The table below introduces elements used for configuring the StoneGate IPS engines. For more information on configuring IPS features, see the *IPS Reference Guide*.

**Table 5.3** Types of Elements in IPS Configuration

Element Type		Explanation
IPS Engines		Configurations particular to individual StoneGate IPS sensor and analyzer engines, such as the interface configuration.
IPS Policies		The rules for inspecting and handling network traffic.
Network Elements		Represent IP addresses. See <a href="#">Network Elements</a> (page 40).
Other Elements	Applications	Provide a way to dynamically identify traffic patterns related to the use of a particular application.
	Ethernet Services	Definitions for protocols that can be used for traffic filtering on the Ethernet level.
	HTTPS Inspection Exceptions	Lists of domains that can be used to exclude HTTPS traffic from decryption and inspection in policies.
	Logical Interfaces	Interface reference that can combine several physical interfaces into one logical entity. Used for defining traffic handling rules.
	MAC Addresses	Represent MAC addresses in Ethernet-level traffic filtering.
	Policy Snapshots	Saved versions of the IPS configuration. Created each time you install or refresh a policy on a sensor.
	Protocols	Supported network protocols. Can be used to define new Services for matching traffic in firewall policies. You cannot add, delete, or modify the Protocol elements.
	Services	Represent network protocols and ports. See <a href="#">Services</a> (page 41)
	Situations	Patterns that deep inspection looks for in traffic. See <a href="#">Situations</a> (page 41).
	TLS Matches	Define matching criteria for the use of the TLS (transport layer security) protocol in traffic, and specify whether TLS traffic is decrypted for inspection.
Vulnerabilities	References that link some Situations to publicly available databases of known vulnerabilities in various software.	

**Table 5.3 Types of Elements in IPS Configuration (Continued)**

Element Type		Explanation	
Other Elements (cont.)	IPS Properties	Antispoofing	Rules for preventing IP address spoofing.
		Routing	Rules for routing traffic.
		SNMP Agents	Configuration information for sending SNMP traps to external components about firewall system events.
		User Responses	Settings for notifying end-users about different policy actions.
		Certificates	Client Protection Certificate Authorities, Server Protection Credentials, and Trusted Certificate Authorities used in HTTPS inspection.

## User Authentication Configuration

The table below introduces elements used for configuring user authentication and directory services. For more information on configuring authentication features, see the *Firewall Reference Guide*.

**Table 5.4 Types of Elements in User Authentication Configuration**

Element Type	Explanation
Authentication Methods	Configured authentication methods for end-user and administrator authentication. Used in rules that require end-user authentication.
Servers	Configured Authentication Servers, RADIUS Authentication Servers, TACACS+ Authentication Servers, Active Directory Servers, and LDAP Servers for end-user and administrator authentication and directory services.
Users	End-users stored in the internal LDAP database, the Authentication Server's LDAP database, and/or an external LDAP database. Used in rules that require end-user authentication.

# Monitoring

Monitoring elements can be used to configure monitoring features in the Management Center (explained in more detail elsewhere in this guide).

**Table 5.5** Types of Elements in Monitoring

Element Type		Explanation	
Diagrams		Allow you to visualize your network environment and monitor the system graphically.	
Incident Cases		Facilitate data collection during security incidents.	
Overviews		Customizable views for system status monitoring, statistics, and shortcuts to configuration tools.	
Reports		Statistical presentations on network traffic and the system.	
Third Party Devices	Logging Profiles	Defines the logging characteristics for a third party device (what data from the third party device logs is shown).	
	MIBs	Allow you to import and browse management information bases to support third-party SNMP monitoring.	
	Probing Profiles	Defines how the Management Server tests if third party devices are running.	
Other Elements	Filters	Allow log data filtering in various tasks.	
	Geolocations	Allow to see on the world map where Hosts (for example, attackers) are located and see how much traffic they create.	
	Monitoring Snapshots	Blacklist	Saved version of blacklist entries for a firewall/VPN or IPS engine. Created when you save a blacklist snapshot in the Blacklist view.
		Connections	Saved version of connection entries for a firewall/VPN or IPS engine. Created when you save a connections snapshot in the Connections view.
		Logs	Saved version of log, alert and audit entries for a firewall/VPN or IPS engine. Created when you save a logs snapshot in the Logs view.
		Users	Saved version of active users for a firewall/VPN or IPS engine. Created when you save a user snapshot in the Users view.
		VPN SAs	Saved version of active VPN SAs for a firewall/VPN or IPS engine. Created when you save a VPN SA snapshot in the VPN SAs view.
	Network Elements	Represent IP addresses. See <a href="#">Network Elements</a> (page 40).	
	Overview Templates	Templates that allow you to create a statistical overview with predefined information selected for the view.	

# Network Elements

Network elements represent IP addresses in firewall/VPN and IPS configurations.

**Table 5.6** Types of Network Elements

Element Type	Explanation
Address Ranges	Define a set of consecutive IP addresses between a start address and end address that you define.
Aliases	Context-dependent elements with no fixed value. The value is defined per engine and is determined when a policy containing the Alias is installed. See the <i>Firewall/VPN Reference Guide</i> or the <i>IPS Reference Guide</i> for more information.
Domain Names	The name of an Internet domain that is automatically resolved by the firewall to all the IP addresses associated with the domain.
Expressions	Allow defining IP addresses using logical operators, which simplifies the definition of complex sets of addresses. See <a href="#">Expressions</a> (page 45).
Firewalls	Configurations particular to individual StoneGate firewall/VPN engines, such as the interface configuration.
Groups	Allows collecting together other Network Elements of any type. Represents all IP addresses defined in the included elements.
Hosts	Represent a single IP address.
IPS	Configurations particular to individual StoneGate IPS sensor and analyzer engines, such as the interface configuration.
Networks	Represent a complete (sub) network of addresses.
Routers	Represents a next-hop router in configurations where specifically required. In policies, represents a single IPv4 and/or IPv6 address.
Servers	Represents a StoneGate Management Center server or an external server that provides a service to the StoneGate system. In policies, represents a single IP address.
SSL VPN Gateways	Information required to integrate an individual SSL VPN appliance with the SMC for monitoring and basic commands.
Traffic Handlers	Configure outbound and inbound traffic management features (load-balancing and high availability).
Zones	Interface reference that can combine several network interfaces of firewall/VPN engines into one logical entity. Used for defining interface matching requirements in traffic handling rules in firewall policies.

# Services

Service elements are used in Access rules to match traffic and to set parameters for handling the traffic. There are predefined system Service elements for official (IANA-reserved) and well-known protocols and services (such as DNS, FTP, HTTP, etc.). You can also create your own custom Service elements to specify a port that is not predefined or to define custom options for handling some types of traffic. See the *Firewall Reference Guide* and the *IPS Reference Guide* for more information.

Table 5.7 Types of Services

Element Type	Explanation
Group	Groups of services that contain the Service elements that together fulfil a certain role, for example, the services needed to allow IPsec VPN connections.
ICMP	Identifies the message by the ICMP Type and Code fields.
IP-Proto	Identifies the protocol by the IP header Protocol field.
SUN-RPC	Identifies the Sun remote procedure call (RPC) service by the program identifier.
TCP	Identifies the service by the TCP header <i>Source Port</i> and/or <i>Destination Port</i> fields.
UDP	Identifies the service by the UDP header <i>Source Port</i> and/or <i>Destination Port</i> fields.
With Protocols	Default Services that contain Protocols that have default parameters set to typically used values.

# Situations

Situation Elements are used in Inspection rules to define patterns that deep packet inspection looks for in traffic. This tree is constructed differently compared to most other trees.

The Situations tree contains several alternative groupings, so most Situations are shown in several places. The groupings allow you to easily find Situations that are specific to the task at hand. For example, Situations specific to Web Browsers (some of which are specific to HTTP) are stored in Situations→By Tag→By Application and situations specific to the HTTP protocol (some of which are specific to particular Web Browsers) in Situations→By Context→Transport Protocols.

Some branches are groupings that you can add to yourself. You can use most of these branches in Inspection rules. The Situation Type groupings are used as the basis for the tree-based Inspection rules configuration in Firewall and IPS Policy elements.

Situations and their groupings are updated in dynamic update packages. The table below lists the default branches at the time of writing this document. See the *Firewall Reference Guide* and the *IPS Reference Guide* for more information.

**Table 5.8 Default Groupings of Situations at the Time of Publishing This Document**

<b>Tree Branch</b>		<b>Explanation</b>
All Situations		All Situations in the system without any grouping.
By Context	Anti-Virus	Events triggered in the virus scanning on StoneGate UTM.
	Application Protocols	Situations that are matched at application protocol level grouped by protocol (for example, HTTP or FTP).
	Correlations	Correlation Situations (Situations for IPS Analyzer engines).
	DoS Detection	Situations for detecting DoS (denial-of-service) attacks.
	Scan Detection	Situations for detecting network scans.
	System	System-internal events in StoneGate components.
	Transport Protocols	Situations that are matched at transport protocol level grouped by protocol (for example, IP or TCP).
By Tag	By Software	Situations that detect something specific to a particular software, grouped by brand or product name (for example, Adobe Acrobat or Microsoft Office).
	By Hardware	Situations that detect something specific to a particular hardware platform (for example, an attempt to exploit a known vulnerability that only works on a particular platform), grouped by platform (for example, x86 (32 bit) or x86-64 (64-bit)).
	By Operating System	Situations that detect something specific to a particular operating system, grouped by operating system (for example, Windows (for all Windows versions), or Windows 2000).
	By Situation Tag	Free-form grouping for some special use cases. The Recent Updates branch is especially useful, as the branches dynamically list Situations that have been recently added to the system in the 1-5 most recent dynamic update packages (helps in tuning your policies).
By Type		These Situations are shown as the main Rules tree in the Inspection rules.
By Vulnerability		Situations that detect attempts to exploit known vulnerabilities grouped by vulnerability name.
Custom Situations		Custom Situations administrators create. Note that custom-made Situations may also appear in the other branches.

# VPN Configuration

The table below introduces elements used for configuring VPNs. For more information on configuring VPNs, see the *Firewall Reference Guide*.

**Table 5.9** Types of Elements in the VPN Configuration

Element Type		Explanation	
Gateways		Configurations particular to individual VPN Gateways, such as the IP address information.	
VPNs		Configurations particular to a particular VPN between two or more VPN gateways.	
Other Elements	Certificates	Gateway Certificates	Information on certificates that StoneGate firewall/VPN engines use as identification in VPNs.
		VPN Certificate Authorities	Certificate issuers whose signature is accepted as proof of identity on certificates in one or more VPNs.
	Profiles	Gateway Profiles	Information on the capabilities of particular types and versions of VPN gateway devices. Allow automatic configuration validation.
		Gateway Settings	Advanced global Firewall/VPN engine settings mainly related to VPN performance tuning.
		VPN Profiles	The main authentication, encryption and integrity checking settings for VPNs.



## CHAPTER 6

# EXPRESSIONS

Expressions are elements that allow creating simple definitions for representing complex sets of IP addresses through the use of logical operands.

The following sections are included:

- ▶ [Introduction to Expressions](#) (page 46)
- ▶ [Operands](#) (page 46)
- ▶ [Expression Processing Order](#) (page 48)
- ▶ [Grouping Operands Using Parenthesis](#) (page 48)
- ▶ [Nesting Expressions](#) (page 49)

# Introduction to Expressions

---

*Expression* is an element that combines other network elements (IP addresses) with logical operands. Expressions make it easier to define complex sets of network resources, even though you can arrive at the same definitions without expressions. For example, a single, simple expression can include a whole network except for a few individual IP addresses scattered throughout the address space. Otherwise, several Address Range elements could be needed to define the same set of IP addresses.

The expressions consist of the following parts:

- *Parenthesis* group sets of elements and define the processing order in the same way as they do in mathematical equations. The parenthesis in expressions are always the basic curved type “(” and “)”.
- *Negation* operands take a set and form a new set that includes every possible element except the ones in the original set. Negations are expressed with “~”.
- *Intersection* operands take two sets and forms a new set that includes only those IP addresses that are found in both sets. Intersections are expressed with “ $\cap$ ”.
- *Union* operands combine two sets and form a new set that includes every IP address in both sets. Unions are expressed with “ $\cup$ ”.

Next, we explain these concepts and their use in more detail, starting with operands.

## Operands

---

### Negation

Illustration 6.1 Graphical Representation of a Negation

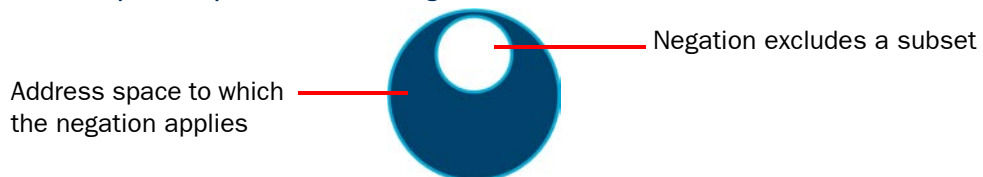

The negation operand can be understood just based on common language use: it corresponds to the word “NOT”. For example,  $\sim 1.2.3.4$  (negation of IP address 1.2.3.4) includes all other possible (IPv4) addresses except the IP address 1.2.3.4. As you see, negations are a good way to create a simple element that includes large IP address spaces with some exceptions.

Usually, the negation will appear in constructions such as this:  $192.168.10.0/24 \cap \sim 192.168.10.200$ . This basically means “include all addresses in network 192.168.10.0/24, except do not include address 192.168.10.200”. This definition utilizes the intersection operand, which is explained next. We will return to this same example to explain the intersection part of the equation. Also, the section explaining the union operand will return to this example once more to explain why a union operand is not appropriate here.

# Intersection

Illustration 6.2 Graphical Representation of an Intersection

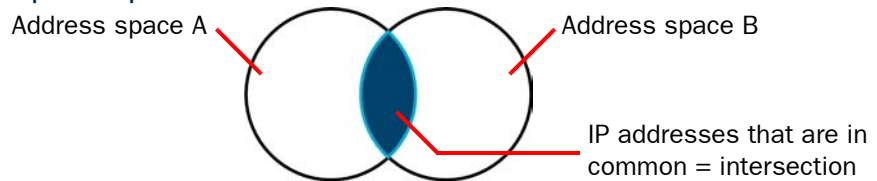

Intersection is perhaps the least intuitive of the operands used in expressions, but it is still quite simple in concept: it means “include only those IP addresses that are a part of both sets”. For example, we could intersect two address ranges, A (192.168.10.200 – 192.168.10.300) and B (192.168.10.250 – 192.168.10.350). The expression reads  $A \cap B$  and it resolves to the following IP addresses: 192.168.10.250 – 192.168.10.300 (the IP addresses that appear in both ranges).

We now return to the previous example on the negation operand, where an intersection was also used:  $192.168.10.0/24 \cap \sim 192.168.10.200$ . On the left side, there is a specific network that we intersect with the right side that contains all possible IP addresses except one IP address. The intersection resolves to the IP addresses that the left side and the right side have in common. These include the IP addresses in network 192.168.10.0/24 except the one IP address that is specifically excluded on the right side of the equation. As shown here, intersections allow us to make expressions more specific. The next operand we present does the opposite.

# Union

Illustration 6.3 Graphical Representation of a Union

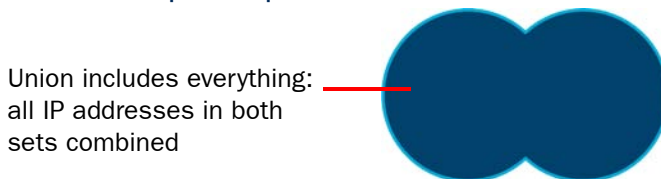

The common language equivalent for the union operand is the word “AND”. The union operand’s role is to widen the scope of the expression. For example, the expression  $1.2.3.0/24 \cup 2.3.4.0/24$  simply includes all of the IP addresses in the two networks. As evident from this example, using unions is basically the same as if you simply include the elements in the same Group element. For this reason, unions are usually not the only operand in an expression, and perhaps a better example would be:  $\sim 192.168.1.1 \cup \sim 192.168.1.255$  (include all IP addresses except the two IP addresses mentioned), although this example is quite wide in scope and may perhaps need a further restriction to become practical (such as an intersection with the network 192.168.1.0/24 to include only addresses in that network).

Unions do have the potential to become too wide in scope if you are not careful. In the preceding text, we used the example expression:  $192.168.10.0/24 \cap \sim 192.168.10.200$ . If we replace the intersection (“ $\cap$ ”) with a union (“ $\cup$ ”) in that example, the expression then includes all addresses from the left side (network 192.168.10.0/24) and all addresses from the right

side (all IPv4 addresses except for one). The expression includes even the single IP address that is excluded on the right side, since it is part of the network on the left side. The result corresponds to the default “Any Network” element that matches all possible IP addresses. The processing order of the operands is also a factor in this result. This is explained next.

## Expression Processing Order

---

The processing order of expressions is fixed. As in mathematical equations, items inside parenthesis are always resolved before other comparisons. Next, the operands are processed by type: first the negations, then intersections, and last the unions.

For example, the expression  $A \cup \sim(B \cup C) \cap D$  is processed like this:

1. The formula between parenthesis is solved first (the union of B and C). If we mark this result with X, the expression will then look like this:  $A \cup \sim X \cap D$ .
2. Next, the negation is processed, inverting the value of X. We will mark this with Y like this:  $A \cup Y \cap D$ .
3. Next, the intersection between Y and D is resolved. We will mark that result with Z, and now the result looks like this:  $A \cup Z$ .
4. Finally, the union of A and Z gives us the actual value that the expression represents (the full contents of both A and Z).

As shown here, the order in which the operand-value combinations appear in the expression have no significance to the order of processing. The only way to change the processing order is by using parenthesis as explained next.

## Grouping Operands Using Parenthesis

---

Parenthesis allow grouping the expression so that the operands you add are processed in a non-standard order. Operands inside parenthesis are always processed before other operands. Parenthesis can also be placed inside parenthesis, in which case the operands are processed starting from the innermost parenthesis.

For example, we can change the example from the previous section ([Expression Processing Order](#)) by adding a set of parenthesis like this:  $(A \cup \sim(B \cup C)) \cap D$ . With the two sets of parenthesis, the inner parenthesis is processed first ( $B \cup C$  as before), the negation is processed next ( $\sim X$  as before), but then the outer parenthesis is processed next instead of processing the intersection, changing the result. If  $\sim(B \cup C)$  results in Y (as before), then the expression will look like this:  $(A \cup Y) \cap D$ . The order of processing is then different than without the parenthesis: instead of intersecting Y and D, the expression performs a union of A and Y and the intersection is then the last operand to be processed.

Complicated expressions with extensive use of parenthesis can become difficult to read and edit. In these situations, nested expressions may sometimes be a better option.

## Nesting Expressions

---

You can nest expressions by placing other expressions inside an expression. Nesting is a good way to simplify the creation of complex expressions. When you construct complex expressions from smaller incremental units, you can more easily find and fix problems. You can also reuse the smaller units in other expressions or policies as appropriate. Arguably, the expressions are also easier to read and edit when broken down into smaller units.

For example, if we want to create an expression that includes all IP addresses in three networks, except for one IP address in each, we end up with quite a long expression:  $(192.168.1.0/24 \cap \sim 192.168.1.1) \cup (192.168.2.0/24 \cap \sim 192.168.2.1) \cup (192.168.3.0/24 \cap \sim 192.168.3.1)$ . Instead of creating just one expression, it may make more sense to create several expressions: one for each set of brackets above (for example, Expression A:  $192.168.1.0/24 \cap \sim 192.168.1.1$ ) and then add either an expression that collects those three expressions together like this:

$\text{Expression A} \cup \text{Expression B} \cup \text{Expression C}$  or simply create a Group element that contains the three expressions. All three sub-expressions can be used individually or easily combined in other ways as needed, for example,  $\text{Expression A} \cup \text{Expression C}$ . Naturally, when changes are made to an expression used inside some other expression, the definitions are updated in both places.

You can also create expressions that you use as templates for creating new expressions: when you insert an expression into another expression, you have the choice of extracting the contents from the expression instead of just inserting the expression. Extracting the contents allows you to make further changes and additions to the expression you insert. Extracting the contents also removes the link between the expressions, so changes are not propagated if the inserted expression is later changed.



# ADMINISTRATION TOOLS

---

## **In this section:**

**Administrator Accounts - 53**

**Domains - 61**

**Categories - 67**



## CHAPTER 7

# ADMINISTRATOR ACCOUNTS

Administrator accounts define administrator rights within the Management Center.

The following sections are included:

- ▶ [Overview to Administrator Accounts](#) (page 54)
- ▶ [Configuration of Administrator Accounts](#) (page 54)
- ▶ [Using Administrator Accounts](#) (page 57)

## Overview to Administrator Accounts

---

You can define administrator rights in fine detail for each administrator according to the administrator's duties. You can give each account different privileges globally, for specific administrative *Domains* (if used), for specific groups of elements, and even individual elements. Depending on the element, there are different levels of access that you can grant.

The Management Server keeps track of all the elements to make sure that administrators do not overstep the rights defined in their account. Administrators can modify an element only if they are allowed to modify all the configurations where the element is used. In addition to the defined privileges, the Management Server also prevents administrators from deleting elements that are still used in some other configuration, from editing the same Policy element simultaneously, and from committing conflicting changes to the same element.

## Configuration of Administrator Accounts

---

Two types of elements represent administrator accounts is StoneGate:

- *Administrator* elements define accounts for administrators who are allowed to manage elements through the Management Client and view information in the Web Portal.
- *Web Portal User* elements define accounts for users who are allowed to view information in the Web Portal. These are discussed in [Creating Web Portal User Accounts](#) (page 57). The Web Portal Server is a separately licensed component.

[Illustration 7.1](#) shows the elements used with Administrator elements.

**Illustration 7.1 Elements for Administrator Account Definitions**

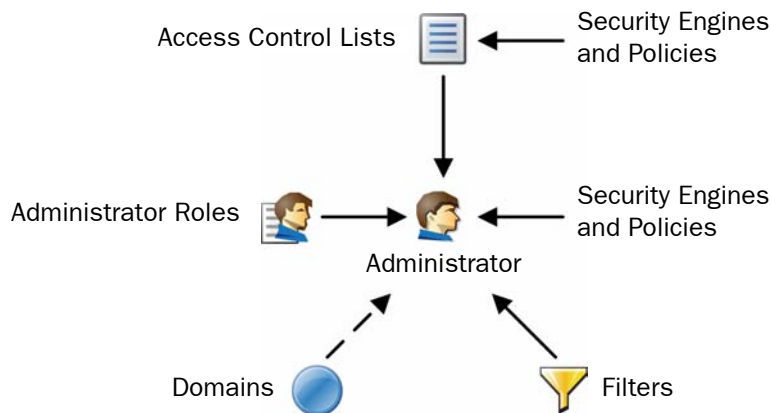

- *Administrator Roles* define sets of allowed actions.
- *Access Control Lists* contain elements and allow you to more easily apply the Administrator Roles to several engines and policies. There are some default Access Control Lists in the system that are automatically populated and can represent additional element types.
- If an administrator is allowed to view logs, you can use *Filters* to select which logs are displayed to the administrator.
- If you use administrative *Domains*, you can give administrators access to any number of *Domains*.

## Default Elements

There are several predefined Administrator Roles and Access Control Lists that help you configure Administrator privileges. You cannot modify the predefined elements.

[Table 7.1](#) describes the predefined Administrator Roles that you can optionally use instead of or in addition to customized Administrator Roles you create. All privileges listed here are always applied to a specific set of elements that you define.

**Table 7.1** Predefined Administrator Roles

Administrator Role	Privileges Given
Viewer	View the properties of elements.
Owner	View the properties, edit, and delete elements. When an administrator creates an element, the administrator is automatically set as an Owner for that element.
Operator	View the properties of elements, send commands to engines, refresh and upload policies, and browse logs and alerts (if applied to components that send logs).
Editor	Operator privileges and additional privileges to create, edit, and delete elements.

All elements automatically belong to one or several predefined Access Control Lists in addition to the Access Control Lists you create yourself.

**Table 7.2** Predefined Access Control Lists

Access Control List	Description
ALL Elements	All elements that are defined in the system.
ALL Administrators	All elements of the type mentioned in the name of the Access Control List.
ALL Domains	
ALL Firewall Policies	
ALL Firewalls	
ALL Incident Cases	
ALL IPS Policies	
ALL Web Portal Users	
ALL Sensors and Analyzers	
ALL SSL VPN Gateways	
ALL Simple Elements	All elements except elements that have a dedicated system Access Control List (as listed above).

The contents of the Access Control Lists are Domain-specific if Domain elements have been configured in the system. For example, in the Shared Domain, ALL Firewalls refers to all the firewalls that belong to the Shared Domain. The ALL Domains Access Control List can be used with Administrator elements only if Domain elements have been configured.

## Configuration Workflow

The following sections provide an overview of the configuration tasks. Detailed step-by-step instructions can be found in the *Online Help* of the Management Client and the *Administrator's Guide* PDF.

### Task 1: Create a New Administrator Role

Administrator Roles define a set of actions that an administrator is allowed to take. Each administrator can have several different Administrator Roles applied to different sets of elements. There are some default Administrator Roles, but if you want to customize the privileges in any way, you must create custom Administrator Role elements.

The Administrator Role contains a fixed list of privileges that you can activate. Select only the minimum necessary permissions for each role. Note that administrators who are allowed to modify administrator accounts can freely give themselves any additional privileges.

### Task 2: Create a New Access Control List

Access Control Lists define granted elements. The Access Control Lists that you create can include security engines and policies. Other elements are handled using the default Access Control Lists. You use the Access Control Lists to define the elements to which the privileges in each Administrator Role apply. For example, if an Administrator Role gives the rights to install policies and browse logs and alerts, you must apply the Administrator Role to security engines in the Administrator element to allow policy installations and log browsing in practice.

The predefined Access Control Lists allow you to give access to all security engines and policies of a certain type. When you create a new element, it is automatically added to the relevant default Access Control List(s). For example, a new Firewall element is automatically included both in the "All Elements" and "All Firewalls" Access Control Lists. You must create custom Access Control Lists if you want to give access to a limited number of elements within one type.

### Task 4: Create a New Administrator Element

We highly recommend that you define a personal administrator account for each administrator. Using shared accounts makes auditing difficult and may prevent timely discovery if there is a security breach.

Administrators can be authenticated internally using a password, or you can use an external server that can provide more advanced forms of RADIUS-based authentication.



**Note – Administrator passwords must be carefully selected and frequently renewed. We recommend that passwords be at least eight characters long and contain combinations of alphabetical, numerical, and special characters. Avoid using any words found in a dictionary, parts of your or your relatives' names, birthdays, home addresses, or similar.**

You can choose between two basic permission levels for the administrators:

- **Unrestricted Permissions** give the administrators the right to manage all elements without restriction, and the right to run scripts which requires the administrators to authenticate themselves.
- **Restricted Permissions** allow you to define the administrator's rights in detail using the Administrator Roles in combination with individual elements and Access Control Lists.

If an administrator is allowed to view logs, you can select an administrator-specific Log Filter for selecting which logs are displayed to the administrator.

If administrative Domains are used, there are some additional considerations:

- Administrator accounts with Unrestricted Permissions must be created in the Shared Domain.
- You must select Domain(s) for each Administrator Role.
- Restricted accounts in the Shared Domain cannot access elements from any other Domains.
- Restricted accounts in other Domains can be granted elements that belong to the Shared Domain. For example, you can grant a policy template from the Shared Domain so that the administrators can view the full contents of the policy.

See [Domains](#) (page 61) for more information.

## Using Administrator Accounts

---

This section provides further information on configuring administrator accounts.

- [Creating Web Portal User Accounts](#) (page 57)
- [Using External Authentication for Administrators](#) (page 58)
- [Customizing Log Color Settings](#) (page 58)
- [Configuring the Administrator Password Policy](#) (page 59)

## Creating Web Portal User Accounts

The accounts for the optional StoneGate Web Portal are defined with Web Portal User elements. It is highly recommended to create a personal administrator account for each Web Portal User. Using shared accounts makes auditing difficult and may prevent timely discovery if there is a security breach. [Illustration 7.1](#) shows the elements used with Web Portal User elements.

**Illustration 7.2** Elements for Web Portal User Account Definition

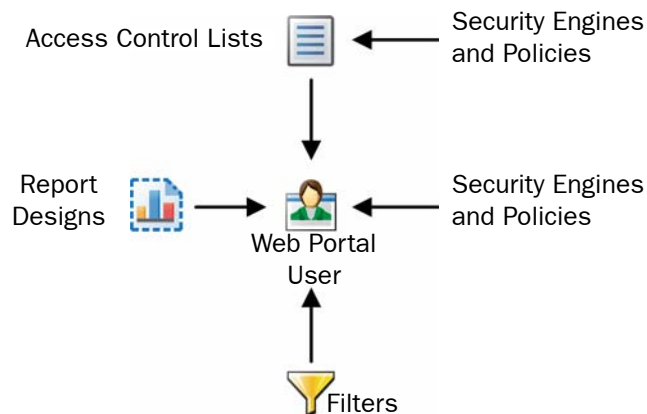

- Engine elements define which logs, reports, and/or policy snapshots are displayed.
- Policies, sub-policies, and template policies define which parts of the policy snapshots are displayed.
- *Report Designs* define which reports are displayed. The Web Portal user is allowed to view all generated reports that are based on the granted Report Designs.
- *Filters* define which logs are displayed. You can also add Filters that the Web Portal User can choose to apply when browsing logs.

Web Portal Users can also utilize internal authentication or external RADIUS authentication.



**Note – Administrator passwords must be carefully selected and frequently renewed. We recommend that passwords be at least eight characters long and contain combinations of alphabetical, numerical, and special characters. Avoid using any words found in a dictionary, parts of your or your relatives' names, birthdays, home addresses, or similar.**

If administrative Domains are used, there are some additional considerations:

- Each Web Portal User account is limited to a single Domain.
- The Web Portal User is allowed all see all the information in the policy snapshots from the granted engines. If a policy's template is in the Shared Domain, the Web Portal User can see also the rules inherited from the template in the policy snapshot.
- The Web Portal Users may be allowed to view reports generated in the Shared Domain depending on their granted elements.

See [Domains](#) (page 61) for more information.

## Using External Authentication for Administrators

You can use an external server (for example, a Windows Server or RSA SecureID) that provides RADIUS-based authentication methods, or the optional Authentication Server component to authenticate administrators' Management Client or Web Portal logins. The supported authentication protocols are EAP-MD5, PAP, CHAP, MSCHAP, and MSCHAP2. The communications are secured using a shared secret.

RADIUS authentication methods are selected individually for each Administrator element and Web Portal User element. The internal user database in StoneGate does not allow access to external components. To use external RADIUS authentication, you must manually create an account both in StoneGate for defining the privileges and in the external directory for the login authentication. The administrator's user name must match exactly on the Management Server and in the directory that the external authentication server uses.

To use RADIUS authentication provided by the Authentication Server component, you must define the Management Server as a RADIUS client of the Authentication Server and link the administrator user accounts to the Authentication Server's user database.

## Customizing Log Color Settings

Different types of logs are displayed with a different background color when you browse log entries in the Management Client. The background colors for log entries are set with Log Filters in the Administrator elements. Administrator-specific log colors make it easier to draw the administrator's attention to particular logs.

## Configuring the Administrator Password Policy

If you authenticate administrators with internal authentication, you can enforce an administrator password policy. The password policy is configured in the `<installation directory>/data/SGConfiguration.txt` file on the Management Server. The currently configured settings are displayed when you enable/disable the password policy in the Management Client. See the *Online Help* of the Management Client and the *Administrator's Guide* PDF for more information on the administrator password policy.

The settings in the administrator password policy are otherwise applied to all the administrator accounts, except you can configure the passwords of individual accounts to never expire in the Administrator or Web Portal User elements.



## CHAPTER 8

# DOMAINS

*Domains* create administrative boundaries in the system, allowing you to create configurations that are kept separate, but managed through the same Management Center.

The following sections are included:

- ▶ [Overview to Domains](#) (page 62)
- ▶ [Configuration of Domains](#) (page 62)
- ▶ [Examples of Domains](#) (page 64)

# Overview to Domains

---

In a large system, there are different geographical sites that are managed by different administrators. Typically, a large part of the administrators only manage components at their own site, and only a few main administrators are responsible for the overall system health across all sites. Domain elements allow you to group together configurations that are, for example, managed by particular administrators or belong to a particular site or customer.

The administrators' rights within a Domain depend on the permissions defined in the administrator accounts. You can grant an administrator access to one or more Domains and define the permissions for each Domain in fine detail.

Domains are a license-controlled feature that is available for purchase through your StoneGate reseller.

## Configuration of Domains

---

When Domains are used, each element automatically belongs to some Domain. An element can only belong to one Domain at a time. By default, all elements belong to the Domain in which they are created.

When administrators log in to a Domain, they can manage the elements in the Domain according to the permissions granted for that specific Domain. In addition, they can also view most elements that belong to the *Shared Domain* even when they are not allowed to log in to the Shared Domain. However, the contents of the elements are only displayed to administrators who have permission to view those elements' contents, and the elements can only be edited from within the Shared Domain. The Shared Domain is meant for elements that are used in several Domains, for example, high-level policy templates. All the default elements also automatically belong to the Shared Domain.

If there already are existing elements when you first start using Domains, all the existing elements belong to the Shared Domain. You can move the elements to other Domains as necessary.

The *ALL Domains* Access Control List is a default Access Control List that you can use in administrator accounts to grant access to all the defined Domains.

## Configuration Workflow

The following sections provide an overview of the configuration tasks. Detailed step-by-step instructions can be found in the *Online Help* of the Management Client and the *Administrator's Guide* PDF.

### Task 1: Create Domains

Only administrators with unrestricted permissions can create, modify, and delete Domains. To manage Domains, you must log in to the Shared Domain. You can create as many Domains as you need.

A service break for the Management Center may be needed for introducing Domains into the system, assigning the existing elements to the correct Domains, and modifying the administrators accounts.

## Task 2: Associate Elements with Domains

Each element automatically belongs to a single Domain. When you create new elements, first log in to the correct Domain and then create the elements, so that the elements automatically belong to the right Domain.

With most elements, you can freely decide to which Domain they belong. However, the following elements always belong to the Shared Domain:

- Domains
- Management Servers
- Secondary Management Servers
- Log Pruning Filters
- Administrator accounts with unrestricted permissions
- The Management Server's internal LDAP user database (the LDAP Domain element called *InternalDomain*). Configure external LDAP servers in the Domains to create domain-specific accounts for end-user authentication.

In addition, there are limitations for selecting the Domain for some elements that are closely associated with other elements:

- A Log Server or Alert Server that is selected as a Management Server's or a Backup Management Server's Log Server or Alert Server must belong to the Shared Domain.
- If a Log Server has a backup Log Server, both Log Servers must belong to the same Domain.
- An Analyzer and the Sensor(s) that send their event data to the Analyzer must be in the same Domain.
- A Task and the target(s) of the Task must be in the same Domain (for example, log exports target Log Servers). Otherwise, the Task cannot be run.
- By default, all the elements used in a VPN must belong to the same Domain. However, you can also use some elements that belong to the Shared Domain (the IPsec Client gateway, Certificate Authorities, Gateway Certificates, Gateway Profiles, Gateway Settings, and VPN Profiles) when you configure a VPN in some other Domain.

You can move existing elements from one Domain to another. Only administrators with unrestricted permissions can move elements between Domains. When you start moving selected elements from one Domain to another, the Management Server automatically checks for element references. You can then either remove the references between the elements or move also the referred or referencing elements. In addition to individual elements, you can also move all elements associated with a Category; using Categories can make moving elements easier if you need to move a large number of them.

## Task 3: Define the Administrator Permissions for the Domains

Once you have defined the Domains and the elements that belong to them, you must also define which administrators are allowed to log in to the Domains and manage the elements.

Accounts with restricted privileges can be created within any Domain, but you cannot move administrator accounts from one Domain to another, so make sure that you are logged in to the right Domain before creating the accounts. Unrestricted accounts can only exist in the Shared Domain. To give an administrator account access to several Domains, you must define the Administrator element in the Shared Domain. Each Web Portal User account is always bound to a single Domain.

See [Administrator Accounts](#) (page 53) for more information.

# Examples of Domains

---

The examples in this section illustrate a common use for Domains in StoneGate and general steps on how each scenario is configured.

## Creating Separate Domains for Different Customers

Company A is a well-known Managed Security Service Provider (MSSP) with a large number of customers. It is important that the networks of different customers are kept separate and that the administrators who manage the customer networks are only allowed to see the networks for which they are responsible. Most of the administrators only manage a single customer's network, but some of the administrators are responsible for several customers' networks.

The administrator at Company A decides to use Domain elements to group together the elements belonging to each customer and to make it easier to manage the different customer networks. The administrator also decides to use Category elements to tag the existing elements that will be included in each Domain. As the user database information must not be available across Domains, the administrator decides to use an external LDAP server in each Domain for user authentication.

Company A's administrator:

1. Arranges a service break with the customers before introducing Domains into the system.
2. Logs in to the Shared Domain and creates the following elements:
  - A separate Domain for each customer.
  - The Administrator elements (the administrator accounts) for the administrators who manage several customers' networks in several Domains.
3. Logs in to each customer's Domain and creates the Administrator elements (the administrator accounts) for the administrators who manage only that particular customer's network.
4. While logged in to each Domain, configures the elements for using an external LDAP server for authenticating the users in the Domain and for storing the Domain's user database.
5. Logs in to the Shared Domain, creates a Category element for each customer, and selects the correct customer-specific Category for each customer's elements.
6. Moves all the customer-specific elements from the Shared Domain to the correct customer-specific Domain.
  - To make it easier to move the elements, the administrator first selects the customer-specific Category and then all the elements that belong to the Category.
7. When all the customers' Domains and their elements have been configured and the service break is over, the administrator's for each customer company log in to the Management Client.
  - The administrators who are responsible for a single customer's networks automatically log in to the Domain assigned to them when they log in to the Management Client. They only see the elements that belong to their own configuration as well as the elements in the Shared Domain.
  - The administrators who have permissions in several Domains must select the Domain when they have logged in to the Management Client.

## Creating Separate Domains for Different Sites

Company B is a large enterprise planning a new system. The system will include 12 different sites, each of which will contain 10 networks. The administrators at each site only need to be able to see the networks at their own sites. As all the sites belong to the same enterprise, the headquarters administrator decides to use the Management Server's internal LDAP user database for user authentication in all the Domains even if this means that all the administrators in each Domain will be able to view the user database information.

The headquarters administrator:

1. Logs in to the Shared Domain and creates Domains to represent each of the 12 sites.
2. Configures the user database and user authentication using StoneGate's internal LDAP directory while logged in to the Shared Domain.
3. Logs in to each Domain that represent a site's configuration and creates the elements for the Domain:
  - The Administrator elements (the administrator accounts) for the administrators of each site.
  - All the other elements that belong to each Domain.
4. When the administrators at each site log in to the Management Client, they also automatically log in to the Domain assigned to them. They only see the elements that belong to their own site's configuration and also the elements in the Shared Domain.



## CHAPTER 9

# CATEGORIES

A *Category* is a label for grouping together related elements for the purpose of filtering elements that are displayed in the Management Client.

The following sections are included:

- ▶ [Overview to Categories](#) (page 68)
- ▶ [Configuration of Categories](#) (page 68)
- ▶ [Examples of Categories](#) (page 69)

# Overview to Categories

---

In a large system, there can be hundreds of elements, but you usually do not need to work with all of the elements at the same time. Category elements allow you to group together related elements according to any criteria you want. Using Categories, you can quickly filter your Management Client view. Elements that do not belong to the selected Category are filtered out so that only the relevant elements are visible. This allows you to manage a large number of elements more efficiently by making it easier to find the elements you need.

## Configuration of Categories

---

You can create as many Category elements as you need. You can modify the contents of the Categories by adding or removing elements. Each element can belong to several Categories.

### Default Elements

There are two predefined Categories:

- The *System* Category is assigned to all the default elements in StoneGate. You can use it to find all the predefined elements in the system.
- The *Not Categorized* Category contains all the elements that have not yet been assigned a Category.

### Configuration Workflow

The following sections provide an overview of the configuration tasks. Detailed step-by-step instructions can be found in the *Online Help* of the Management Client and the *Administrator's Guide* PDF.

#### Task 1: Create Categories

You can create as many Categories as you need. You can base the Categories on any criteria. For example, you can create separate Categories for elements related to different geographic locations.

#### Task 2: Associate Elements with Categories

You can select any number of Categories for each element without restrictions. There are no automatic checks to consider; elements that reference each other do not need to be in the same Category.

#### Task 3: Select a Category to Filter the Displayed Elements

The Category Filters are selected in the toolbar of the Management Client. You can select any combination of Categories. For example, you could apply a Category for a particular geographic location and a Category for critical servers at the same time to view only elements related to the critical servers at one site. Once activated, the Category filtering is applied in all views.

## Examples of Categories

---

The examples in this section illustrate some a common uses for Categories in StoneGate and general steps on how each scenario is configured.

### Creating Separate Categories for a Firewall and an IPS Configuration

Company A is a large enterprise planning a new system. The system will include several firewall and IPS engines. Each firewall and IPS engine has its own policy. The company's administrators only need to manage the firewall engines and their policies or the IPS engines and their policies at a time. To restrict which engines and policies are displayed, the following steps are taken:

1. The headquarters administrator creates two categories: one for the elements that belong to the firewall configuration and another for the elements that belong to the IPS configuration.
2. The headquarters administrator creates the elements that represent the firewalls, firewall policies, IPS engines, and IPS policies and selects the appropriate Category to each element while defining its properties.
3. The administrators select the appropriate Category as the Category Filter so that only the elements in the firewall or IPS configuration are displayed.

### Combining Categories

Company B has sites in New York, Toronto, and Mexico City. The company's administrators have defined separate Categories for the elements that belong to each site as the administrators usually work with the elements of only one site at a time. Today, however, Administrator A needs to apply the same configuration changes to the New York and Toronto sites. Administrator A does not want to create a new Category for this temporary need. To be able to filter the elements belonging to both the New York and Toronto sites into view, Administrator A does the following:

1. Selects the New York and Toronto Categories in the Category Filter Toolbar.
2. Applies the filter so that the elements at both the New York and Toronto sites are displayed, and elements in the Mexico City Category are filtered out.
3. Makes the configuration changes on the two sites.
4. Deactivates the Category Filter to display all elements again.



# LOGS, ALERTS, AND REPORTS

---

## In this section:

[Filters](#) - 73

[Log Management](#) - 81

[Alert Escalation](#) - 89

[Reports](#) - 99

[Incident Cases](#) - 109



## CHAPTER 10

# FILTERS

*Filters* are descriptions of log fields and their values combined together with operations for the purpose of sorting log data. Filters can be used, for example, to select which logs are displayed in the Logs view or which logs will be archived or exported.

The following sections are included:

- ▶ [Overview to Filters](#) (page 74)
- ▶ [Configuration of Filters](#) (page 74)
- ▶ [Examples of Filters](#) (page 80)

# Overview to Filters

Network traffic can generate a large amount of log data. Filters serve as a tool for selecting the desired data from among all the log data. The Filters allow you to pinpoint any value or combination of values that you want to find or exclude; any field that appears in the data can be used for filtering.

You can use Filters for selecting data in the following tasks:

- Browsing logs, alerts, audit data, blacklists, and currently open connections.
- Pruning log data.
- Archiving, exporting, and deleting logged data.
- Creating reports.
- Restricting which logs administrators are allowed to view and selecting different highlight colors for the displayed entries.

## Configuration of Filters

Filters can be constructed and saved as elements in the system, which is required for most of the tasks listed in the overview above. When browsing data, filtering criteria can alternatively be added and removed flexibly without explicitly creating an element.

Regardless of the way a Filter is created, it always consists of one or more *log fields*, a *value* for each field, and *operations* which describe how the fields are combined together. Each Filter is matched to the log data field by field. If the value in the entry is identical with the value for the same field in the Filter, the field matches. If the value is different, the field does not match. Then, the fields are examined together based on the selected operations that combine the fields together as a Filter.

**Illustration 10.1** Matching Events with a Filter

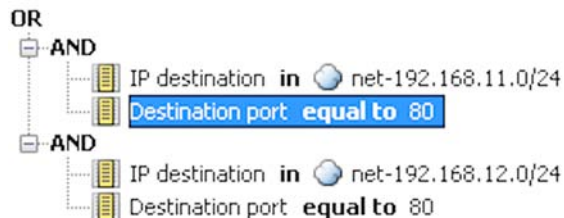

**Illustration 10.1** shows a Filter with several fields and operations. This Filter matches if the destination IP address is in the 192.168.11.0/24 network AND the destination port is 80 OR if the destination IP address is in the 192.168.12.0/24 network AND the destination port is 80.

A data entry of a connection to host 192.168.11.10 on port 80 matches the first AND operation in the example filter. The same connection does not match the second AND operation in the Filter. Since the two AND operations are combined with OR, the Filter as a whole is considered a match and the data is selected for the task that is being carried out.

Since there are different types of data entries, all entries may not contain any value for some field that a Filter contains. For example, an Alert entry warning you that the monitoring connection from a firewall engine has been lost does not contain any source or destination IP address information, since the entry is not related to traffic processing. If you apply the example

filter in the log browser, the Alert is filtered out of the view by default, but you can adjust this behavior in Filters you create. The missing values that cannot be verified as matching or non-matching are called *undefined values* in the configuration.

## Default Elements

There are many predefined filters in the system that you can use for various tasks. You cannot modify the predefined Filters. Filter elements can be imported and updated when you activate new dynamic update packages, so the selection and names of predefined filters may change. The default filters have the type *System* or *Correlation* (for filters used in default IPS Analyzer configurations).

## Configuration Workflow

The following sections provide an overview of the configuration tasks. Detailed step-by-step instructions can be found in the Management Client's *Online Help* and the *Administrator's Guide* PDF.

### Task 1: Create a New Filter

Actively browsing data entries often requires constantly changing the data filtering to display events of interest. To facilitate this, you can add temporary filtering criteria interactively when browsing data. This way, you can use select values from displayed entries and use them as filtering criteria. These temporary filters can be saved as permanent Filter elements and edited, which can be a good way to start creating filters.

However, when you have a particular need for a specific type of filter, it is usually more effective to start by creating a blank new Filter element.

### Task 2: Add Fields

When log data is filtered, the fields/field values in the log data are compared to the field(s)/field value(s) in the Filter. The fields in the Filter define the type of data that interests you.

A Filter can have one or several fields. The more fields you have in the Filter, the more specific the selection of log data becomes. For example, if you are interested in traffic from a certain source IP address, you can use the "IP source" field in the Filter and get a selection of log data that matches the source IP address of your choice. To limit the selection of log data even further, you could add a field for the destination port used.

Different types of data entries contain different types of information, so the fields you add usually also restricts the general type of data that your filter matches. It is possible to create a filter that can never match any data if the combination of fields is not found in any single entry. However, everything depends on the general structure of the Filter, and it is quite possible to create filters that match related data in different types of entries using different fields as criteria.

## Task 3: Add Operations

Operations define how field values in log data are compared to the field values defined in the Filter. You can have as many operations in a Filter as necessary, and you can also nest operations inside other operations. Each two fields you add must always be combined using an operation.

There are three operation types to choose from:

- *Calculation* operations perform mathematical calculations. See [Table 10.1](#) for details.
- *Comparison* operations check values against other values. See [Table 10.2](#) for details.
- *Logical* operations combine the different filtering criteria. See [Table 10.3](#) for details.

**Table 10.1 Calculation Operations**

Operation	Description
bitwise AND	Bitwise AND operation is done bit-by-bit on the provided values. This means that the resulting value of any given bit is “1” only when it has the value “1” in both of the values to be compared.
sum of	Sums the values of the defined fields.

**Table 10.2 Comparison Operations**

Operation	Description
between	Matches when the value on the left-hand side of this operation is in the range of the right-hand side.
contains	Matches when the value on the left-hand side of this operation contains one of the values on the right-hand side.
defined	Matches when the data entry has some value in the field. This overrides the Filter’s general setting for handling empty fields by translating the empty field to an explicit non-match.
equal to	Matches when the value on the left-hand side of this operation is equal to the value on the right-hand side.
greater than	Matches when the value on the left-hand side of this operation is larger than the value on the right-hand side.
greater than or equal	Matches when the value on the left-hand side of this operation is larger or the same as the value on the right-hand side.
in	Matches when the value on the left-hand side of this operation belongs to the value on the right-hand side.
is false	Matches when the value of a Boolean type of field is <i>false</i> .
is true	Matches when the value of a Boolean type of field is <i>true</i> .
like (case insensitive)	Matches when the value on the left-hand side of this operation is equal to the right-hand side without considering character capitalization.

**Table 10.2 Comparison Operations (Continued)**

<b>Operation</b>	<b>Description</b>
like (case sensitive)	Matches when the value on the left-hand side of this operation is equal to the right-hand side when considering character capitalization.
map size exceeded	Matches when the size of the selected map structure is exceeded.
require all occurrences of	Matches only when all the values match.
require any occurrence of	Matches when any of the values matches.
less than	Matches when the value on the left-hand side of this operation is smaller than the value on the right-hand side.
less than or equal	Matches when the value on the left-hand side of this operation is smaller or the same as the value on the right-hand side.

**Table 10.3 Logical Operations**

<b>Operation</b>	<b>Description</b>
AND (Require all of)	Matches when all included criteria are found to match.
OR (Require any of)	Matches when any one of the included criteria is found to match.
NOT	Matches always except when the included criteria is found to match.

## **Task 4: Add Values to the Fields**

Depending on the field, you can define one to several values that you want to look for in the data. There are some operations (for example, Defined) for which a field value is not needed

## **Task 5: Define Handling of Missing Values**

As previously mentioned, you can adjust what happens when the Filter is matched to data that does not contain any value for a field that the Filter defines. For example, if a Filter looks for a specific destination address, but is matched to audit logs, which do not contain traffic filtering information. By default, log data matches the Filter only if all the fields in the Filter are also found in log data.

If you want to define in more detail how missing fields are handled, you have two options:

- The *Undefined value policy* setting defines whether log data matches the Filter if there are missing fields.
- The *Defined* operation (one of the Comparison operations) allows you to define specific fields in the Filter the log data must always have regardless of the undefined value policy (independently from any value that the field contains).

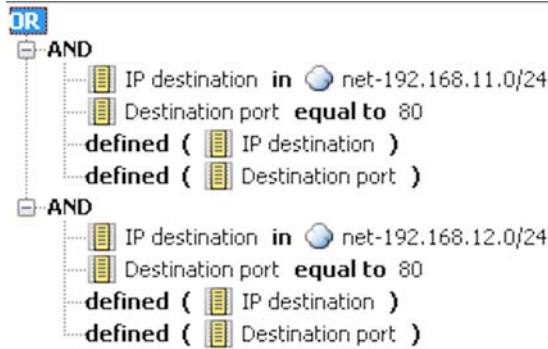

Illustration 10.2 gives an example of the use of the Defined operation. Both of the AND operations require that the log data has the fields preceded by the Defined operation (the IP destination and Destination port fields). Data entries that do not have these fields do not match the Filter.

You can use one of the four Undefined value policy settings to define how missing values are handled. The setting works differently depending on the structure of the Filter. The results of logical operations (AND, OR, NOT) in the Filter depend on the Undefined value policy setting. A logical operation is usually either *true* or *false*. However, if a fields in the Filter does not exist in a data entry, the logical operation is left *undefined*.

The Undefined value policy settings are described in Table 10.4.

Table 10.4 Undefined Value Policy Settings

Setting	Description
False by comparison	A Comparison operation is <i>false</i> if log data does not have all the fields used in the Filter. Depending on the structure of the Filter, the log data does or does not match the Filter. For example, if the outermost operation in the Filter is AND, the log data does not match the Filter if any of the inner operation is <i>false</i> .
False by filter	Log data does not match the Filter (the Filter is <i>false</i> ) if the outermost operation in the Filter is <i>undefined</i> because log data does not have all the fields used in the Filter.
True by filter	Log data matches the Filter (the Filter is <i>true</i> ), if the outermost operation in the Filter is <i>undefined</i> because log data does not have all the fields used in the Filter.
Undefined	If the outermost operation is <i>undefined</i> because log data does not have all the fields used in the Filter, the <i>undefined</i> result is passed to the StoneGate component that uses the Filter. The handling of the <i>undefined</i> result varies according to the component that uses the Filter.  In most cases, this setting works in the same way as “False by filter”. If the outermost operation is <i>undefined</i> because log data does not have all the fields in the Filter, the data does not usually match the Filter. However, the IPS Analyzers handle the <i>undefined</i> result as “True by filter”, which means that the log data matches the Filter.

These four different **Undefined value policy** settings are compared below with an example.

**Illustration 10.3** Undefined Values When Matching an Event

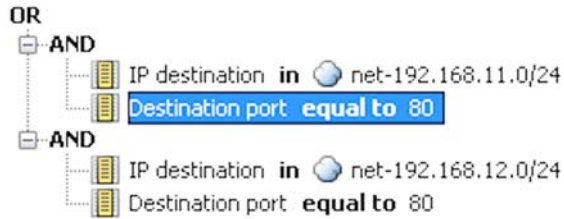

The example Filter in [Illustration 10.3](#) has the IP destination and Destination port fields. ICMP traffic, for example, does not have the Destination port field. If ICMP traffic is matched with the example Filter, the filtering results vary according to the selected Undefined value policy:

- False by comparison: The AND operations are *false*. As a result, also the OR operation is *false*. The event does not match the Filter.
- False by filter: The AND operations are *undefined* (neither *true* nor *false*). As a result, also the OR operation is *undefined*. The setting interprets the *undefined* result as *false*. The event does not match the Filter.
- True by filter: The AND operations are *undefined* (neither *true* nor *false*). As a result, also the OR operation is *undefined*. The setting interprets the *undefined* result as *true*. The event matches the Filter.
- Undefined: The AND operations are *undefined* (neither *true* nor *false*). As a result, also the OR operation is *undefined*. The Undefined setting passes the *undefined* value to the StoneGate component that uses the log data. The handling of the data varies according to the component. Most components handle the data in the same way as False by filter, so that the event does not match this Filter. The IPS Analyzer, in contrast, handles the *undefined* value as True by filter, so that the event matches the Filter if the Filter is used by the Analyzer.

## Task 6: Organize the Filters

You can optionally create Filter Type elements and add those to Filters to organize them. All filters are listed according to Filter Type in the element trees. This makes it easier to find the correct Filter.

## Examples of Filters

---

The examples in this section illustrate some common uses for Filters and general steps on how the scenarios are configured.

### Creating a Filter for Logs Concerning Authenticated Users

Company B wants a report of StoneGate users who have authenticated themselves within a certain time frame. To create the report, the company's administrator needs a Filter to select the logs concerning the authenticated users. The administrator:

1. Creates a new Filter.
2. Selects the Auth. User field to filter the user names of authenticated users.
3. Selects the "equal to" operation.
4. Adds the wildcard "\*" as the value to the Auth. User field to match all authenticated users in log data.

### Creating a Filter for Pings in a Network Excluding a Host

Company C's administrator has noticed that the number of ping attempts (ICMP echo requests) in the internal network has increased. The administrator wants a report of all the pings that have been made lately in the local network to make sure, for example, that the servers in the internal network have not been taken over by an outsider. The administrator frequently pings from the HOST 2 workstation in the internal network. The administrator wants to create a report of the ping attempts and wants to exclude pings from HOST 2 from the report. The administrator needs a new Filter for generating the report. The administrator:

1. Creates a new Filter in which the source IP address field in log data is compared to the internal network's addresses and the ICMP type is compared to Echo.
2. Adds a condition that the IP address in the log data may not belong to the HOST 2 workstation.

Illustration 10.4 Filter Excluding A Host

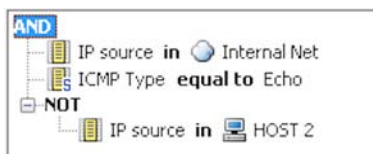

## CHAPTER 11

# LOG MANAGEMENT

Log management is the process of configuring when logs are produced, which of the produced logs are stored, and when stored logs can be deleted or archived.

The following sections are included:

- ▶ [Overview to Log Management](#) (page 82)
- ▶ [Configuration of Log Management](#) (page 83)
- ▶ [Using Log Management Tools](#) (page 85)
- ▶ [Examples of Log Management](#) (page 86)

# Overview to Log Management

---

Logs provide you with important information on what is going on in your network environment. However, not all the logs are equally important, and none of the logs need to be stored forever. Log management is needed to keep the amount of logs at a reasonable level and to prevent logs from filling the Log Servers. This is where various log management tools will help you.

The security engines send their logs to their configured Log Server, except the IPS sensors, which send their logs through the analyzers, which further process the logs. The Log Server either stores the entries or just relays them to be viewed in the Current Events mode in the Logs view. Some logs may be discarded through pruning before these operations. When you view logs, the information is fetched directly from the Log Servers. Some other tasks, such as processing data for statistical reports, are also partially carried out by the Log Server.

There are three types of data entries that are covered by these log management tools. These are explained next.

## Log Entries

*Log entries* are most often triggered by Access rules. Other types of rules can be set to create log entries as well, but in most recommended configurations, the volumes are usually much smaller than in Access rules. The system can also produce detailed *Diagnostic logs* and always produces some other internal log entries (such as policy installation related entries).

## Alert Entries

*Alert entries* are notifications of important events that require the administrator's attention. The practical difference between alerts and normal log entries is that alerts are highlighted in the Management Center and they can be escalated through various external notification channels. In addition to rule matches, alerts can be produced when an automatic test fails, a monitored element becomes unreachable, or if there is a system error.

SSL VPN alerts are classified as regular log entries in the Management Center.

Setting up external notifications for alerts is discussed in [Alert Escalation](#) (page 89).

## Audit Entries

*Audit entries* provide a record of administrator actions and some internal events in the Management Center, such as creation, modification and deletion of elements, administrator logins, and the execution of scheduled tasks. This data is useful, for example, when troubleshooting the cause of malfunctions caused by undocumented configuration changes.

Only the Management Server and the Log Server send audit entries. The audit entries are stored on the Management Server or the Log Server that originally created them.

## Domain Boundaries

If administrative Domains are configured, all log, alert, and audit entries are Domain-specific. When you log in to a Domain, only the entries related to that specific Domain can be viewed or managed. However, Audit entries from all Domains are displayed to administrators that are logged in to the Shared Domain.

# Configuration of Log Management

Log entries are stored in *log files*. If these files are never removed, they will eventually fill up the entire drive on the Log Server. You can launch different types of tasks to manage the logs. Some older entries can simply be deleted, while more important entries can be backed up by archiving them in their native StoneGate format or exporting them to some external format. It is a good idea to set up some log management tasks to run automatically at regular intervals using the internal tools.

Sometimes the system may generate some unnecessary log entries that can be awkward to remove, for example, if a single rule generates both useful and uninteresting log entries. In such a case, it is sometimes easiest to reduce the amount of logs by pruning log entries. You can discard irrelevant log entries by using *log pruning filters*. The following illustration demonstrates how log pruning filters are used in log management.

**Illustration 11.1 Log Pruning**

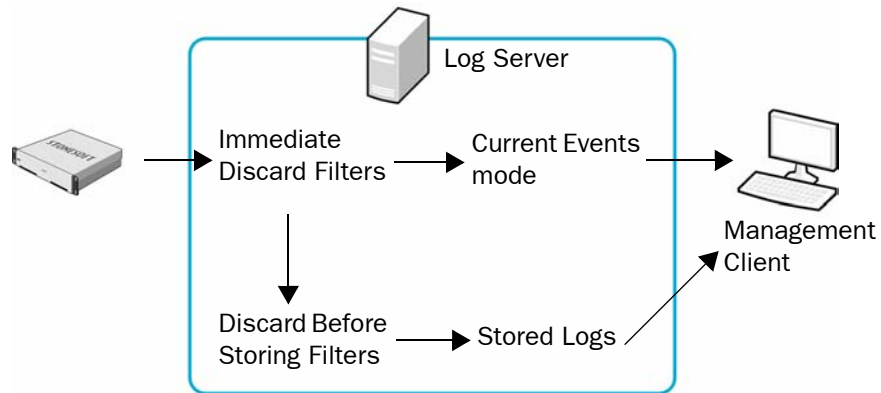

As the illustration shows, you can prune log entries in two phases using *Immediate Discard* filters and *Discard Before Storing* filters. Immediate Discard filters delete log entries as they arrive to the Log Server. The Discard Before Storing filters delete log entries before the log entries are stored on the Log Server.



**Note - Alert entries and audit entries cannot be pruned.**

# Configuration Workflow

The following sections provide an overview of the configuration tasks. Detailed step-by-step instructions can be found in the *Online Help* of the Management Client and the *Administrator's Guide* PDF.

## Task 1: Define Logging Options

The primary way to manage logging is to set up the system to create all necessary logs and alerts and a minimum of unnecessary log entries. The main generator of logs that you can configure are the rules in traffic handling policies. Another major point of configuration is the automatic tester, which you can set up to create alerts on various events. Logs and alerts are generated by some other features as well, but do not generally offer many tuning possibilities.

## Task 2: Define Log Tasks

*Log Tasks* can export, archive, and delete logs. It is possible to schedule these tasks to run automatically. The greater the volume of log data, the more frequently cleanup operations must run. For example, if the number of stored log entries is constantly high, you may need to export and delete logs daily. The schedules are defined in the Management Client's local time. This needs to be taken into account if the Log Server has a different time zone.

If administrative Domains are used, Log Tasks are always Domain-specific. You must define and run the Log Tasks in a specific Domain to apply them to the log data in that Domain.

[Table 11.1](#) explains the different types of log data tasks you can run.

**Table 11.1** Log Task Types

Log Task	Explanation
Export Log Task	Export XML copies the selected log data to a separate file in XML/CSV format.
	Export CSV copies the selected log data to a separate file in comma-separated (CSV) format.
	Export IPS Recordings as PCAP/Snoop copies IPS traffic recordings to be viewed in an external application in PCAP or Snoop format.
Archive Log Task	Copies the selected log data to the current archive folder in StoneGate log file format. The archive task can be set up to additionally delete data.
Delete Log Task	Deletes the selected data from the current log files on the Log Server.

## Task 3: Configure Log Pruning

You can manage the amount of log data by defining log pruning filters. Log pruning is needed, for example, when a rule generates both useful and unnecessary logs. Log pruning gives you the ability to discard newly generated irrelevant logs entries on the Log Server. Only logs can be pruned: alerts and audit entries are never pruned.

It is preferable to adjust log generation options instead of letting log entries be generated and then pruning them, as this wastes system resources in creating and transferring the unnecessary logs.

You can define two types of log pruning filters:

- *Immediate Discard* filters delete log entries immediately as they arrive to the Log Server. The deleted log entries are not displayed in the Management Client.
- *Discard Before Storing* filters deletes log entries before they are saved. Log entries are shown the Current Events mode in the Logs view before they are deleted (in effect, this option converts Essential or Stored type log entries into Transient log entries).

If Domain elements have been configured, log pruning filters can only be defined in the Shared Domain. The same log pruning filters are used in all Domains. Administrators who have the right to manage log pruning can view the log pruning filters when they are logged in to other Domains.



**Caution – Be careful when defining the pruning filters. The matching log events are irreversibly deleted at the Log Server.**

## Using Log Management Tools

---

### About the Log Files

Logs are stored as a files on the Log Server. A separate folder is created for the logged events each hour. The log files are stored by default in the `<installation directory>/data/storage/` directory on the Log Server.

The log files have the following naming: `YYYYMMDD_hh_C<ORIGINATOR>_MMDDhhmmsssss.arch`.

- The date `YYYYMMDD_hh` refers to the date and hour of the logged events.
- The rest of the file name starting with “\_c” refers to the file creation date and the `<ORIGINATOR>` refers to the originator of the logged events.

The time and date in the file name always use the UTC time zone, which is the system’s internal time zone.

### Archive Directories

Log files are archived by default in the Log Server’s default archive directory `<installation directory>data/archive`. You can change this directory and define up to 32 alternative or additional directories. For example, you could directly archive some or all of the logs on a network drive to free resources on the Log Server. See the *Online Help* of the Management Client and the *Administrator’s Guide* PDF for more information.

### Exporting Log Data to Syslog Servers

Log entries can be exported from a Log Server to external *syslog servers*. The log entries are selected with log filters. The filters must be exported to a file to be used for syslog filtering. Of log pruning is applied, any entries that pass “immediate discard” pruning can be sent to the syslog servers. Entries do not need to be stored on the Log Server to be sent to the syslog server. See the *Online Help* of the Management Client and the *Administrator’s Guide* PDF for more information.

# Examples of Log Management

The examples in this section illustrate some common uses for log management in StoneGate and general steps on how each scenario is configured.

## Archiving Old Logs

Last month's logs are taking up too much disk space on the Log Servers at Company A, but some of the logs are still needed for the company's records. The administrators decide to archive the needed logs on another server and to delete last month's log data from the Log Servers. Because not all the logs from last month need to be archived, they delete the unnecessary logs altogether. They want to repeat the same archiving operation once a month from now on. To do this the administrators:

1. Create a new Archive Log Task for archiving the data with the following settings:

**Table 11.2** Archive Log Task for Company A

Option	Setting
Time Range	Last Full Month
Filter for Copying	A custom filter which matches the important log data that the administrators want to archive.
Filter for Deletion	<b>Match All</b> to delete all last month's logs from the Log Server.
Archive Target Directory	A network drive.

2. Save the new Archive Log Task.
3. Create a new Scheduled Task for running the Archive Log Task and set it to be repeated monthly.
4. Save the Scheduled Task.

## Filtering Out Irrelevant Logs

**Illustration 11.2** Company B's Network

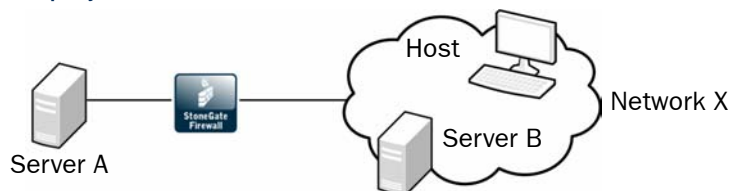

Server A provides services to users in network X, as well as to Server B. The administrators are interested in tracking how many of the users in network X actually use Server A. Server B also connects frequently to Server A, and generates a large amount of traffic.

Since Server B makes very frequent connections to Server A and the administrators are only interested in connections from other hosts in network X to Server A, the administrators decide to temporarily eliminate logs that are a result of Server B's connections. All hosts in network X including Server B are currently logged according to a single rule. Creating a separate rule to handle just the Server B connections with logging set to "None" would create unnecessary clutter in the policy when the administrators only want to filter the logs from Server B temporarily. The administrators decide to set up log pruning to filter the logs so that only the relevant ones are stored on the Log Server. To do this the administrators:

1. Select one of the irrelevant log entries in the Logs view.
2. Create a temporary filter based on the log entry, and save the filter as a permanent filter.
3. Add the new filter to the Discard Before Storing list in the Log Data Pruning view.



## CHAPTER 12

# ALERT ESCALATION

Alert Escalation means defining when and how the system notifies the administrators when an alert entry is created.

The following sections are included:

- ▶ [Overview to Alert Escalation](#) (page 90)
- ▶ [Configuration of Alert Escalation](#) (page 90)
- ▶ [Using Alert Escalation](#) (page 93)
- ▶ [Examples of Alert Escalation](#) (page 96)

# Overview to Alert Escalation

---

Alert entries inform the administrators if there is a problem with the StoneGate system, test or task failure, or if a rule of particular interest matches (usually mainly Inspection rules). Alert entries can be viewed in the Logs view in the same way as other logs, but of course it is not wise to rely on administrators noticing critical messages from the general log stream. This is why Alerts have an escalation process that can notify the administrators of new alerts in several different ways.

By default, notifications of new alert entries are shown in the Management Client. You can also configure the Log Server to send alert notifications out from the system through different channels according to various criteria.

Some form of alert escalation is useful in any environment. We recommend you make sure that the system attracts the attention of the administrators to at least those alert entries that indicate problems in the system components (System Alerts).

## Configuration of Alert Escalation

---

Illustration 12.1 Alert Escalation

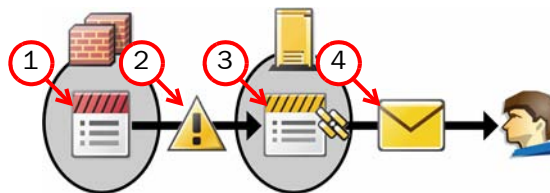

The alerts are handled as follows:

1. An alert entry is triggered on a system component.
2. The alert entry is sent to the Log Server, which stores it. At this point, administrators can view the alert in the Logs view.
3. The Log Server matches the alert entry to its *Alert Policy* to select the correct *Alert Chain*.
4. The Alert Chain triggers a series of notifications.

For example, an Alert Chain can first notify one of the administrators by e-mail, wait for acknowledgement for 10 minutes, and if the alert is not acknowledged in time, the Log Server can notify this or some other administrator with a mobile phone text message. Alert notifications are sent until the alert is acknowledged by one of the administrators or when the Alert Chain is completed.

Alert escalation is highly configurable, so you can for example:

- Define which alert entries are escalated to which administrators based on who is responsible for which components.
- Configure different alert escalation rules for weekends and evenings.
- Set up alert escalation so that if administrators responsible for, for example, a branch office site do not acknowledge an alert, the alert escalation continues to administrators at a nearby site or at the headquarters.

## Default Elements

By default, the system includes the following alert-related elements:

- **System Alert:** this Alert element is used for alerts triggered by critical events in the system's internal operation (the System Situations explained below).
- **Default Alert:** this Alert element is used in the default Inspection rules. You can also use it in your own custom configurations.
- **Test Alert:** this Alert element is used when you test alert handing.
- **Default Alert Policy:** this Alert Policy contains a rule that escalates all alerts using the Default Alert Chain.
- **Default Alert Chain:** this Alert Chain escalates all alerts to all administrators using the User Notification channel (alert icon in the Management Client).
- **System Situations:** the System Situations contain definitions for problems in the system that trigger a System Alert. There are no configurable parameters for System Situations and you cannot adjust when these Situations are triggered. When you configure alert escalation, make sure that your custom Alert Policies escalate the System Alerts as well, because the System Alerts always require administrator action.

## Configuration Workflow

The following sections provide an overview of the configuration tasks. Detailed step-by-step instructions can be found in the *Online Help* of the Management Client and the *Administrator's Guide* PDF.

### Task 1: Define Custom Alerts

You can define your own custom Alert elements. This allows you to create more granular alert escalation policies and writing more specific alert messages. If you set up the Log Server to send SNMP traps when alerts are triggered, custom Alerts allow you to define the SNMP code for the associated alert entries.

The alerts you see in the Logs view contain more information than you define for your custom Alert element; alert entries are always triggered by some event, and information regarding the event (such as the Situation that matched in an inspection rule) is automatically included in the alert entry in the Logs view and when the alert entry is escalated. How much information is included depends on the Alert Channel.

### Task 2: Define Alert Chains

Alert Chains define how, in which order and to whom alert notifications are sent. Alert Chains contain a list of actions that are executed from top to bottom. Each row in an Alert Chain defines a channel through which a notification is sent. The available alert channels are:

- **Custom Script:** executes a script on the Log Server.
- **SMS:** sends an SMS text message through an attached cellular modem.
- **SMTP:** sends an e-mail.
- **SNMP:** sends an SNMP trap.
- **User notification:** triggers a notification in the status bar of the Management Client.

You can also add delays in the Alert Chains between the notifications to give the administrators time to respond. When the Alert Chain reaches the end you can choose out of several actions:

- The alert escalation can stop.
- The alert can be automatically acknowledged.
- The alert can be escalated to some other Alert Chain.
- The alert processing can return to the referring Alert Policy for further matching.

### Task 3: Define Alert Policies

The Alert Policy defines if any particular alert entry is escalated or not. An Alert Policy contains rules for matching incoming alert entries. Alert entries that match an Alert Policy rule are escalated to the Alert Chain defined in the rule. If an alert entry does not match any rule in the Alert Policy, the alert entry is not escalated.

Alert Policies are stored on the Management Server and you must install the Alert Policy on a Log Server whenever you change the Alert Policy rules or the Alert Chains used by those rules (even if the Log Server is installed on the same computer as the Management Server). If the Log Server has no Alert Policy installed, alert entries are escalated according to the Default Alert Policy.

The fields in Alert Policy rules are explained in the table below.

**Table 12.1** Alert Policy Fields

Field	Explanation
Sender	Allows you to limit the rule to match alerts entries generated by one or more particular StoneGate components.
Alert and Situation	Allows you to limit the rule to match alert entries that are based on one or more particular Alert elements or Situation elements.
Time	Allows you to limit the time of day and weekdays when the rule is active. The time parameter allows, for example, defining different notifications for weekends or night time.
Severity	Allows you to limit the rule to match alert entries that have a Severity value from within a certain range. You can, for example, escalate only the most severe alerts that have Critical as the severity value using the e-mail Alert Channel, and then escalate the other alerts only through a User Notification in the Management Client.
Chain	Defines the Alert Chain that is used for escalating matching alert entries.
Comment	Your optional free-form comment for this rule.
Tag	Rule tag.

## Task 4: Configure Alert Channels

Most Alert Channels require that you configure integration with external components, such as a cellular modem or an e-mail server. This is done in the properties of the Log Server element(s). The Alert Channels that require configuration are presented in the table below.

Table 12.2 Configurable Alert Channels

Alert Channel	Configuration
Custom Script	Define the absolute path to the folder where the script to be executed is placed.
SMTP (E-mail)	Define the SMTP server's address and the sender information that is used in the e-mail: the e-mail sender name and return address.
SMS (Text Message)	Define the COM Port with a connected SMS-capable GSM mobile phone or modem. You must also type in the PIN Code if the mobile phone requires the PIN code.
SNMP	Define the SNMP Gateways used.

## Using Alert Escalation

---

### Acknowledging Alerts

New alerts are in the active state and they remain active until an administrator acknowledges them. After you receive an alert notification, you must acknowledge the alert in the Logs view. When you acknowledge an alert, the alert is no longer processed and no more notifications are sent.

In the Logs view, the properties of each acknowledged alert display the alert event traces, for example, information on the sent notifications, and the administrator who acknowledged the alert and when.

In a system with default settings, administrators must actively monitor the system to notice any alert entries signalling problems in the system's operation. Alert escalation can be set up to send messages out from the StoneGate system to draw the attention of administrators concentrated on other tasks.

## Information Included in Alert Notifications

The amount of information the alert notification includes depends on the Alert Channel used as detailed in the table below.

**Table 12.3** Contents of Escalated Alerts

Alert Channel	Information Included in the Notification
Custom Script	Depends on the script you create. See <a href="#">Using a Custom Script for Alert Escalation</a> (page 94).
SMTP (E-mail)	Includes the full details of the alert, the full situation description, and the contents of all hex viewable fields as a hexadecimal dump and ASCII.
SMS (Text Message)	The maximum length for an SMS notification is a single SMS of the standard 160 characters. Only the log fields that fit into the notification message are selected, in the following order: Situation name, Severity, source IP address, destination IP address, destination port, Sender, Logical Interface, and the creation time of the alert.
SNMP	Only the log fields that fit into the notification message are selected, in the following order: Situation name, Severity, source IP address, destination IP address, destination port, Sender, Logical Interface, alert creation time, traffic recording excerpt, and the application protocol.

## Designing Alert Policies and Alert Chains

The system reads the Alert Policies and Alert Chains from top down, so the order of the rules is important. In Alert Policies, rules must proceed from those with the most limited scope to those that are the most general. In Alert Chains, the order of the rules determines the order in which the alert notifications are sent.

## Using a Custom Script for Alert Escalation

For custom script alert channel, you must define the absolute path to the script to be executed (if it is not pre-filled correctly). There is an example notification script `<installation directory>/data/notification/notify.bat` in Windows (`notify.sh` in Linux) that can be modified for your own use. On Linux, the `sgadmin` user needs read, write, and execute permissions in the script's directory.

The alert information is given to the script as command arguments as described in the table below.

**Table 12.4** Arguments Passed to Custom Scripts

Argument number	Content	Description
1	Alert ID	Identifies the alert uniquely in the system.
2	Alert Name	The name defined in the alert properties.

Table 12.4 Arguments Passed to Custom Scripts (Continued)

Argument number	Content	Description
3	Alert Originator	The IP address of the Sensor, Analyzer, Firewall, or other system component that generated this alert.
4	Alert Date	The date when the alert was originally generated.
5	Alert Message	A short alert description.
6	Alert Severity	The Severity value of the alert from 1 to 10 where 1 is the least severe and 10 is the most severe. The numerical Severity value corresponds to the following Severity value in the generated alert: 1= Info, 2-4=Low, 5-7=High, and 8-10=Critical
7	Alert Short Description	The contents of the Comment field in the alert properties.
8	Event ID	IPS only: reference to the event ID that triggered the alert.
9	Situation Description	Long description of the situation that triggered the alert.

When the alert script is executed, the output (stdout) is appended to the `notify.out` file in the script's directory. The error output (stderr) is appended to the `notify.err` file in the script's directory.

The Linux script in [Illustration 12.2](#) is an example of how to create an operating system log entry using the custom script alert notification.

**Illustration 12.2 Example Custom Alert Script**

```
#!/bin/sh
# This script uses the 'logger' utility to create an operating system
# log entry of the StoneGate Log Server alert notification.
PATH=/bin:/usr/bin

# Create log entry: "StoneGate Alert (<ALERT_ID>): Severity <SEVERITY>
#   : <ALERT_NAME> : <ALERT_DESCRIPTION>"

/usr/bin/logger "StoneGate Alert ($1): Severity $6 : $2 : $5"

exit 0
```

# Examples of Alert Escalation

The examples in this section illustrate some common uses for Alert Escalation in StoneGate and the general steps on how each scenario is configured.

## Disabling All Alert Escalation for a Specific Situation

The administrators at company A notice that the system is producing an alert every time that someone mistypes their password when logging in using the Management Client. They decide that they do not want to receive alert notifications about failed logins, because they have set up their StoneGate IPS system to detect if there are several failed logins within a short period of time (such a pattern could indicate malicious activities).

The administrators:

1. Create a new Alert Chain and name it Auto-acknowledge.
2. Set the final action for the Auto-acknowledge Alert Chain to Acknowledge without adding any new rows.
3. Add the following new rule at the top of the Alert Policy:

Table 12.5 Alert Policy Rule Example

Sender	Alert and Situation	Chain
ANY	“Management Server: Login Failed” Situation element	“Auto-acknowledge” Alert Chain

4. Refresh the new Alert Policy on the Log Server. After this change, the alerts for failed logins are still generated and stored, but they do not trigger any alert notification and they never show up as active alerts in the System Status view or the Logs view. For example, reports can include failed login attempts to highlight excessive login failures.

## Escalating Alerts Based on Responsibilities

Company B has two sites, a branch office (BO) and a headquarters (HQ) site, which both have their own administrators. Both sites have a StoneGate Firewall and a Log Server, and the shared Management Server is located at the HQ.

For the most severe alert entries, the administrators decide to set up alert escalation as a text message to the shared mobile phone each site has for the administrator on duty. If the administrator on duty at one site does not acknowledge the alert entry within 15 minutes, the alert notification is sent to the administrator on duty at the other site.

For less severe alert entries, the alerts are only escalated to the site where the alert entry is created. At first, the less severe notifications are sent only through a User Notification in the Management Client. After an hour, the alert notification is sent to the shared mobile phone of the site where the alert entry is created.

This scenario could be configured in other ways as well, but this time, the administrators:

1. Create new Alert Chains for high-severity and low-severity alert entries for both the HQ and the BO sites. There are four Alert Chains in total:
  - “HQ Important Alerts” contains the following rules:

**Table 12.6 “HQ Important Alerts” Alert Chain**

Channel	Destination	Delay
SMS	[Phone number for HQ shared mobile phone]	15 min
SMS	[Phone number for BO shared mobile phone]	

- “HQ Minor Alerts” contains the following rules:

**Table 12.7 “HQ Minor Alerts” Alert Chain**

Channel	Destination	Delay
USER NOTIFICATION	HQ Administrator A HQ Administrator B [etc.]	60 min
SMS	[Phone number for HQ shared mobile phone]	

- The “BO Important Alerts” and “BO Minor Alerts” Alert Chains are basically the same as the HQ Alert Chains, just with BO Administrators and phone number.

2. Create a new Alert Policy with the following rules:

**Table 12.8 Example Alert Policy**

Sender	Alert and Situation	Severity	Chain
HQ Firewall HQ Log Server Management Server	ANY	High ... Critical	HQ Important Alerts
HQ Firewall HQ Log Server Management Server	ANY	Info ... Low	HQ Minor Alerts
BO Firewall BO Log Server	ANY	High ... Critical	BO Important Alerts
BO Firewall BO Log Server	ANY	Info ... Low	BO Minor Alerts

3. Define the SMS channel in the HQ Log Server’s properties.
4. Define the SMS channel in the BO Log Server’s properties.
5. Install the new Alert Policy on both Log Servers.



## CHAPTER 13

# REPORTS

Reports are summaries of logs and statistics, which allow combining large amounts of data into an easily viewable form.

The following sections are included:

- ▶ [Overview to Reports](#) (page 100)
- ▶ [Configuration of Reports](#) (page 100)
- ▶ [Using Reporting Tools](#) (page 104)
- ▶ [Examples of Reports](#) (page 107)

# Overview to Reports

StoneGate provides extensive reporting tools for generating reports on information stored in the system. The summaries that make up the reports can be illustrated with different types of charts and tables.

You can create reports on log, alert, and audit entries as well as statistical monitoring information. Only logs in the active log storage are used in log-based reporting. Archived logs are ignored. Additionally, a special System Summary report can be generated to provide a summary of element, administrators, policies, and such system-related details.

A variety of ready-made Report Designs are provided. You can design new reports or customize the existing templates to meet your needs.

## Configuration of Reports

Reports are summaries of log data and statistical monitoring information. Reports consist of *report Items*, *report sections*, and *Report Designs*. The following illustration shows their relationships.

Illustration 13.1 Reporting Objects and Elements

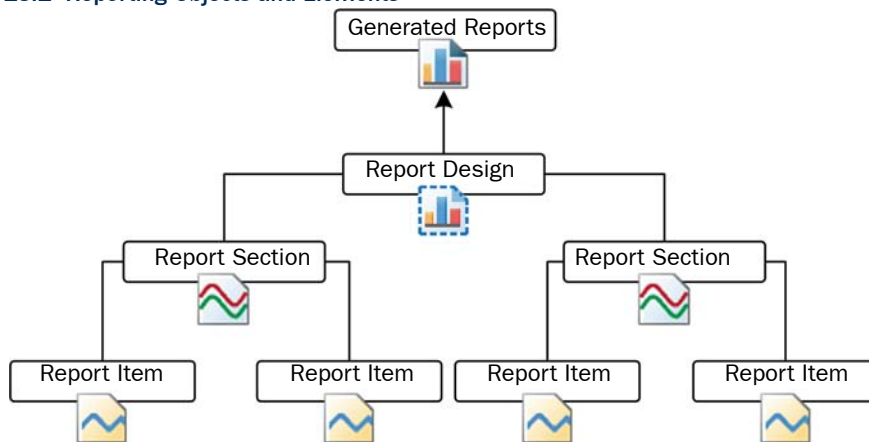

The Report Design is the main container for a particular type of report. The Report Designs are used as the basis for reporting tasks that generate the reports that you can view.

The Report Design consists of one or more report sections. A report section defines parameters for all items within, mainly how the information is displayed (such as the type of chart and the number of top items shown). Each report section in the Report Design creates a separate chart and/or a table in the generated report.

Each report section contains one or more report items, which each represent a way to summarize the data, for example the total number of connections (counted for the period between the start and end times defined for the task that generates the report). Each item adds an item to the chart or table that the report section generates: for example, if the report section displays a curve chart and contains items for total traffic volume, sent traffic volume, and received traffic volume, the generated report shows the three items as three separate lines on the same chart.

Illustration 13.2 shows how the Report Designs, report sections and report items are displayed in the Management Client.

Illustration 13.2 Report Designs, Report Sections, and Report Items

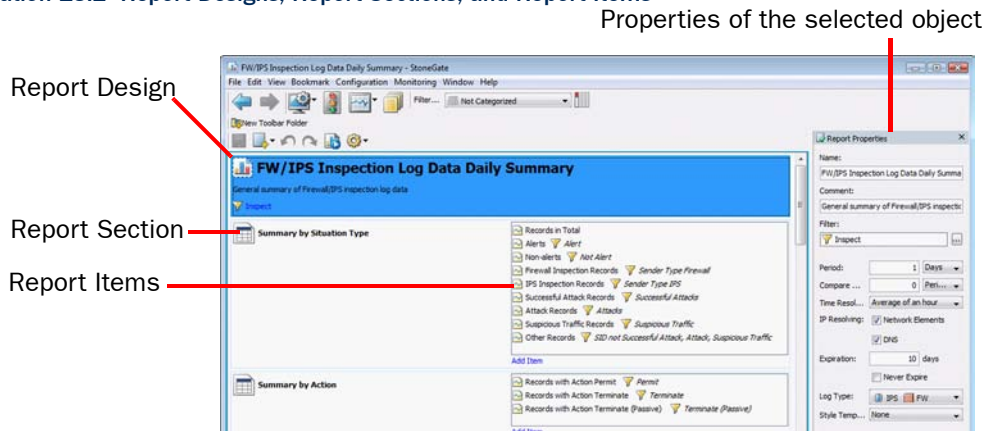

## Filtering Data in Reporting

The report items define some general criteria for selecting data, for example, you can produce a report of connections by source IP address. This is good way to get an overview, but in many cases, you want more specific information. Log filters are the main tool for increasing the granularity of reports.

For example, a very general item such as the total number of logged connections can be made much more specific by applying a log filter that matches a single pair of source and destination IP addresses (to count connections between just those two specific hosts).

Only log-based raw data is suitable for log filters. Counter Statistics items process statistical monitoring information instead of logs, so most log data filters cannot be used with Counter Statistics report items. Log filters that specify the sender (the StoneGate component that generated the statistics) can be used with Counter-based items, and may be useful in Reports.

You can define a filter at one or more of the following stages:

1. Report task (applies to the single report produced by a particular task, or to all reports produced by a task that is scheduled to run regularly).
2. Report Design (applies to all reports produced using the Report Design).
3. Each report section (applies to all items included in the section).
4. Each report item (applies to that specific item only).

If filters are applied at several of these stages, all filters are applied and the log entries are filtered top-down in the order listed. Each filtering stage completely excludes non-matching log entries for the stage in which the filter is applied and all further stages. For example, if you select a filter for TCP destination port 80 for a report section, all items in that section only process information in log entries that mention TCP destination port 80.

## Section Types

Each report section produces its own summary in the report. Depending on the summary type, the summary can be presented as a bar chart, a curve chart, a pie chart, a geolocation map, or a table. The available types of report section summaries are explained in [Table 13.1](#).

**Table 13.1 Summary Types**

Type	Description	Appearance
Progress Summary	<p>Illustrates how events are spread out within the reporting period. This summary type is useful for finding trends in the data.</p> <p>Example: a line chart showing the volume of traffic during a 24-hour period.</p>	A bar chart or a curve chart.
Top Rate Summary	<p>Illustrates events with the highest occurrences. This summary type is useful for highlighting the most common values in the data.</p> <p>Example: a bar chart showing the number of connections to the five IP addresses that have received the most connections yesterday.</p> <p>The first report item in a top rate summary section must have a sorting criteria “by X” (for example, allowed connections by source IP address), because the sorting criteria is applied to all the items of the section for ranking the top rates.</p>	A bar chart, a pie chart or a geolocation map. A bar chart is more suitable for displaying a large number of top rates, whereas a pie chart or a geolocation map is better at illustrating the relative proportions.
Summary Table Summary	<p>A simple table for displaying the exact event counts. This summary type is useful for providing data for further processing, for example, in a spreadsheet application.</p>	A table.
Drill-Down Top Rate Summary	<p>First, creates a top rate summary of events. Then, sections below use the data in the top rate summary to produce further charts and tables.</p> <p>Example: a drill-down that shows the top ten IP addresses in terms of traffic volume, followed by a further progress summary that shows in detail how the combined traffic from those IP addresses is spread throughout the week.</p> <p>Drill-down sections must be at the end of the Report Design. All other sections that you place below a drill-down top rate summary section in the Report Design become part of the drill-down top rate summary, except other drill-down sections (and the sections they include).</p>	A bar chart, a pie chart or a geolocation map.
System Information	<p>Summarizes current configuration information in the Management Server’s internal database.</p> <p>Example: a listing of all engines with the software versions, names of the currently installed policies, and the latest policy upload times.</p>	A table.

# Configuration Workflow

The following sections provide an overview of the configuration tasks related to configuring and customizing reports in the Reports view. Detailed step-by-step instructions for configuring reports can be found in the *Online Help* of the Management Client and the *Administrator's Guide* PDF.

## Task 1: Create a New Report Design

Reporting tools are in the Monitoring Configuration view.

There are several ways to create new Report Designs. Although you can start by defining a new empty Report Design, it is often easier to use one of the predefined Report Designs as a template. The comments in the properties of predefined Report Designs and Sections explain their general purpose.

The Report Design properties specify, for example, the time period for the report. You can define a *period comparison* for the Report Design. This allows you to compare values between two identical time periods. For example, if the time period is one week, you can compare the results for this week to the results from the previous week. You enter the times in the local time of your workstation, and the times are then automatically converted (according to the workstation's time zone setting) to universal time (UTC), which the system uses internally.

You can also use a log data filter for selecting the data for the report or set an expiration date for automatically deleting all reports that are generated using the design.

## Task 2: Add a New Report Section

A report section represents a collection of report item data in reports. Each report section adds a separate summary (chart and/or table) in the report. You can create one or several empty report sections and then select their contents. Alternatively, you can add predefined report sections to your Report Design and then modify their contents and properties.

You can make changes to a section by selecting the section on the left panel and typing your changes to the properties in the panel on the right. The most important selection here is the type of chart you want to produce, the number of top items (for top rate charts), and the types of log data you want to include. Some selections affect your choice of items: System Information sections restrict your choice to system summary information, restricting the included log data types may prevent using items that process excluded types of logs, and a drill-down summary needs a specific type of item (as explained below).

## Task 3: Add Items to the Section

A report item represents a value that you want to count in log data or statistical monitoring information (for example, allowed traffic in bits or the number of allowed connections). You cannot create new report items.

When you add items, make sure the correct Section is selected. All items are not compatible to used together in the same chart/table, so the list of available items is automatically restricted to only show valid items when the currently selected section already contains one or more items.

The data for the report items is generated in the following ways:

- A simple count of how many log entries have a certain value within the reporting period. For example, the Allowed Connections report item counts the log entries that have the value Allowed in the Action field. This is how the results for most report items are summed.
- A count of how many log entries have a certain value within the reporting period grouped by the additional “by X” criteria. For example, Allowed connections by source IP address presents a chart for an adjustable number of IP addresses that have the most allowed connections within the reporting period.
- Sums or averages of traffic volumes in log entries for report items of the “traffic” type (for example, Allowed traffic). The data for “traffic” items is generated by Access rules that have the accounting option enabled in the Firewall Policy. Interface statistics often provide more accurate total volumes, since accounting (and logging in general) is not usually active for all rules.
- Values stored in the Management Server’s database for items of the System Information section type. These are called “counters”. The statistical data is pre-summarized, so it is not as detailed as the monitoring statistics displayed in the System Status view, and cannot be filtered in detail like the log data (see [Filtering Data in Reporting](#) (page 101)).

## Using Reporting Tools

---

### Generating Reports

When you start a report task, the Management Server sends the task to the Log Servers for processing (all Log Servers that are not specifically excluded). The task’s progress and possible errors are shown next to the task under the selected Report Design. Each Log Server processes the task and returns the summary data for each report section. The Management Server merges the data from the Log Servers into one report. If one of the selected Log Servers cannot be contacted for any reason, the execution of the task is delayed until the Log Server becomes available.



**Note – Each report task needs to scan through the selected log data only once. It requires less processing to generate more sections in a report than to generate a separate report, which requires scanning the data again.**

If there are Domains configured in the system, the reports are Domain-specific. While logged in to a Domain, you can only create reports concerning the components that belong to that Domain. If you are allowed to log in to the Shared Domain and have unrestricted permissions, you can create Reports concerning components in any Domains. The Reports created in the Shared Domain are visible to administrators in all other Domains. If the reports contain sensitive data that should not be displayed to all the administrators in all Domains, create the reports in a specific Domain. See [Domains](#) (page 61) for more information.

## Using the System Report

While other reports are based on logs and statistics, the System Report is based on information collected from the Management Server's configuration database. It includes such details as administrator and Web Portal user activity, information on account settings, configuration of and changes to the Firewall and IPS engines, and the configuration of the Management Server. The System Report is intended to help you provide the required data for auditing in compliance with regulations, such as the Payment Card Industry (PCI) Data Security Standard. The System report is generated, exported, and edited in the same way as other types of reports: the only difference is the content of the report.

## Exporting Reports

You can export the generated reports from the system as PDFs or tab-delimited text files. PDF exports allow you to use your own background template. The export can be done manually or automatically as part of the report generating task.

Automatically exported files can be automatically sent out as e-mail and/or saved in the `<installation directory>/data/reports/files/report_design/` directory on the Management Server. The report files are named according to the report's time range as follows: `startdate_starttime_enddate_endtime_N.pdf` (or `.txt`), where *N* is a sequential number (starting from 1) that identifies files with the same time range. For example, `20100423_100000_20100424_180000_1.txt` is the first text report generated for the time range from 23 Apr 2010 10:00:00 to 24 Apr 2010 18:00:00.

## Tab-Delimited Text Report Files

Tab-delimited text files are designed to be used for further processing. The tab-delimited text files contain the statistics in tabulated tables. The Tab characters and the operating environment specific line endings delimit the text.

**Table 13.2** Structure of a Tab-Delimited Text Report File

Line No.	File Content	Description
1	<Report Title>, <Start Time> - <End Time>	Start and End Time define the reporting period in format YYYY/MM/DD hh:mm:ss.
2	<empty line>	
3	<Section Content for each section>	Each section of the report follows the format described below.
Line No.	Section Content	Description
1	<Section Name>[: <Section Comment>]	Optional Section Comment with a leading semi-colon (;) may follow the Section Name.
2	<empty line>	
3-	<Section Data>   "No data"	Section Data follows the format described below. If the section contains no data, the text "No data" is displayed instead.

**Table 13.2 Structure of a Tab-Delimited Text Report File (Continued)**

Section's last line	<empty line>	
Line No.	Section Data Content	Description
1	<Table Heading>	Tab delimited column labels. Some columns may not have a label, and labels may be padded with trailing spaces.
2	<empty line>	
3-	<Table rows>	Tab delimited values. Value in any given column can be empty. The column values are not padded.
Section data's last line	<empty line>	

## Post-Processing Report Files

You can customize reports by post-processing them as part of the report generating task. Post-processing runs the `<installation directory>/data/reports/bin/sgPostProcessReport` script on the Management Server, and passes command arguments to the script. [Table 13.3](#) explains the possible command arguments.

**Table 13.3 Command Arguments for Post-Processing Reports**

Command Argument	Explanation
<code>-creation_time YYYY/MM/DD hh:mm:ss</code>	The report creation time.
<code>-filter_categ name</code>	The category assigned to the task filter.
<code>-filter_name filter</code>	The name of the filter assigned to the task.
<code>-html_file filename</code>	The filename of a report exported as HTML.
<code>-pdf_file filename</code>	The filename of a report exported as PDF.
<code>-period_begin YYYY/MM/DD hh:mm:ss</code>	The begin time of the reporting period.
<code>-period_end YYYY/MM/DD hh:mm:ss</code>	The end time of the reporting period.
<code>-report_categ name</code>	A category assigned to the report (and to the report file).
<code>-report_file_title title</code>	The title of the report file.
<code>-report_name name</code>	The name of the report.
<code>-text_file filename</code>	The filename of a report exported as plain text.

The script needs to parse the values from the command arguments to use the values for post-processing. Only parameters that have a defined value are forwarded to the post-processing script.

When a parameter has multiple values, each of the values is forwarded as a separate command argument. For example, when the report has the two categories “ABC Corp.” and “weekly report”, these values are forwarded to the script as “-report\_categ ABC Corp.” and “-report\_categ weekly report”.

## Examples of Reports

---

The examples in this section illustrate common uses for reports and general steps on how the scenarios are configured.

### Pinpointing a Disruptive Internal User

Administrators at Company A notice that the network downloads have gone up dramatically over the past week. They suspect that there may be an individual user that is excessively downloading files from the Internet. To confirm their suspicions, the Administrators decide to run a report that shows them who has used most bandwidth in the network.

The administrators:

1. Activate Accounting for each rule that allows connections from internal hosts to the Internet (incoming connections to internal workstations are not allowed) and install the policy.
2. Wait for a full workday for the logs with accounting information to be generated.
3. Generate a log data filter that matches the IP address space of regular workstations as the source address and any external IP addresses as the destination address.
4. Create a new Report Design based on the Firewall Daily summary and attach the Log Filter created in the previous step to the Report Design.
5. Increase the “Top Limit” value for the section “Traffic by src. IP” from 10 to 15 to see a list of top 15 IP addresses to see more results.
6. Generate a report for the previous day to check the traffic volumes for the top 15 hosts.



## CHAPTER 14

# INCIDENT CASES

The Incident Case element is a tool that helps you record investigations of suspicious activity.

The following sections are included:

- ▶ [Overview to Incident Cases](#) (page 110)
- ▶ [Configuration of Incident Cases](#) (page 110)
- ▶ [Examples of Incident Cases](#) (page 112)

# Overview to Incident Cases

---

When suspicious activity is detected, it is important to collect all the information about the incident and act quickly. The Incident Case element allows you to gather together all the data, actions, system configuration information, and files related to a specific incident. This information is useful for effective incident investigation, and also helps to provide evidence in the case of legal action or to demonstrate compliance with operational standards.

## Configuration of Incident Cases

---

Incident cases can be started as needed, and you can then add various types of information from the system to them, along with your own comments.

### Configuration Workflow

The following sections provide an overview of the configuration tasks. Detailed step-by-step instructions can be found in the *Online Help* of the Management Client and the *Administrator's Guide* PDF.

#### Task 1: Create an Incident Case

The Incident Case element stores all the information related to the incident. When you create an incident case, the Data Collection, Player List, and Journal tabs are visible. The History tab is situated at the bottom of the view along with the General tab.

Table 14.1 Incident Case tabs

Tab	Explanation
Data Collection	Allows you to attach information that is needed to provide context for investigating an incident.
Player List	Lists the elements or IP addresses that were involved in the incident.
Journal	Allows you to record comments about administrator actions during the incident investigation.
General	Shows you the summary of the Incident Case you select from the list of Incident Cases.
History	Automatically gathers and displays all the log and audit entries that track actions performed in this incident case.

For your own reference you can give the incident case one of four predefined priorities ranging from Low to Critical. The priority you define is for your own categorization and does not affect the way the case is handled in StoneGate.

## Task 2: Set the Management Client to Incident Handling Mode

You can set your Management Client to work in the context of solving a particular Incident Case. When you do this, the Management Client attaches the selected Incident Case in the audit trail that the system generates of your actions. The audited actions can then be easily viewed through the history of the selected Incident Case.

## Task 3: Attach Data

The following types of data can be attached to the Incident Case:

Table 14.2 Data Collection

Data Item	Explanation
Logs	Log, alert, and audit entries from firewall or IPS engines and Log and Management servers.
Policy Snapshot	A record of record of a configuration stored in the upload history. Policy Snapshots help to establish which policies were in place at the time of the incident.
Memo	A simple text file for attaching excerpts of text, for example, by copying and pasting from e-mail, IRC or instant messaging.
File	Any type of file. For example, saved reports, text files, saved e-mail messages, packet capture files, or screenshot images.

## Task 4: Attach Players

A player is any element or IP address that was involved in the incident. Attaching players to an incident case creates a reference to a StoneGate element.

## Task 5: Write Journal Entries

The journal allows administrators to keep a record of what actions they have performed and why they have performed them while investigating the incident. It is especially useful when more than one administrator is investigating the same incident simultaneously.

Once a journal entry is saved, it cannot be edited. This provides an audit for incident management (for example, to be used as evidence in court).

## Task 6: Close the Incident Case

When the investigation is finished, you can close the incident case. The incident case stays in the system, but its state is marked as closed. It is a good idea to keep resolved incident cases as a record of past incidents or for future reference in dealing with new incidents.

# Examples of Incident Cases

---

There are many ways an administrator can become aware of suspicious activity in the system. However, the most likely way is by noticing something unusual in the logs or audit entries, or being warned about a potential problem in an alert. Once a suspicious event is detected, the workflow generally follows one of these scenarios:

## Investigation by More Than One Administrator

1. An administrator creates a new incident case.
2. The administrator delegates work to other administrators.
3. Each administrator collects data and players, and attaches them to the incident case.
4. An administrator reacts to contain the incident, for example, by stopping an engine or changing a Firewall policy.
5. An administrator may try to eradicate the problem, for example, by installing software patches or updating anti-virus programs.
  - The administrator can write a new comment in the incident journal to inform the other administrators about what has been done.
6. When the problem is resolved, the administrator closes the incident case.

## Investigation of a False Positive

1. The administrator creates a new incident case.
2. While collecting data, the administrator discovers that the suspicious event was not a real problem.
3. The administrator marks the incident case as a false positive.

## Investigation of Suspected Backdoor Traffic

The administrator receives an IPS alert that there is active two-way backdoor traffic between a server in the organization's internal network and an unknown host in the Internet. The administrator then:

1. Opens a new incident case to help manage this incident.
2. Searches for previous logs from the Firewall and IPS engines to identify the vulnerability that allowed the server to be compromised.
3. Attaches the relevant logs to the incident case.
4. Re-installs the server, and installs patches to prevent the same vulnerability from being exploited again.
5. Closes the incident case.

# APPENDICES

---

## **In this section:**

**Default Communication Ports - 115**

**Command Line Tools - 125**

**Predefined Aliases - 143**

**Log Fields - 147**

**Schema Updates for External LDAP Servers - 191**

**Glossary - 193**

**Index - 223**



## APPENDIX A

# DEFAULT COMMUNICATION PORTS

This chapter lists the default ports used in connections between StoneGate components and the default ports StoneGate uses with external components.

The following sections are included:

- ▶ [Management Center Ports](#) (page 116)
- ▶ [Firewall/VPN Engine Ports](#) (page 118)
- ▶ [IPS Engine Ports](#) (page 122)

# Management Center Ports

The illustrations below present an overview to the most important default ports used in communications between the Management Center (SMC) components and from the SMC to external services. See the table below for a complete list of default ports.

**Illustration A.1 Destination Ports for Basic Communications Within SMC Management Client**

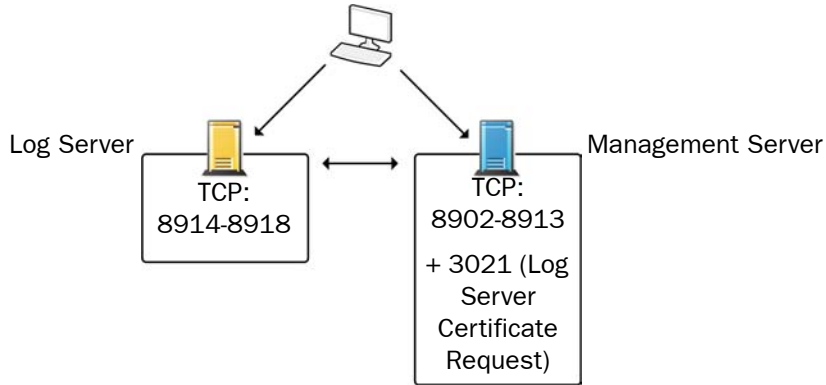

**Illustration A.2 Default Destination Ports for Optional SMC Components and Features**

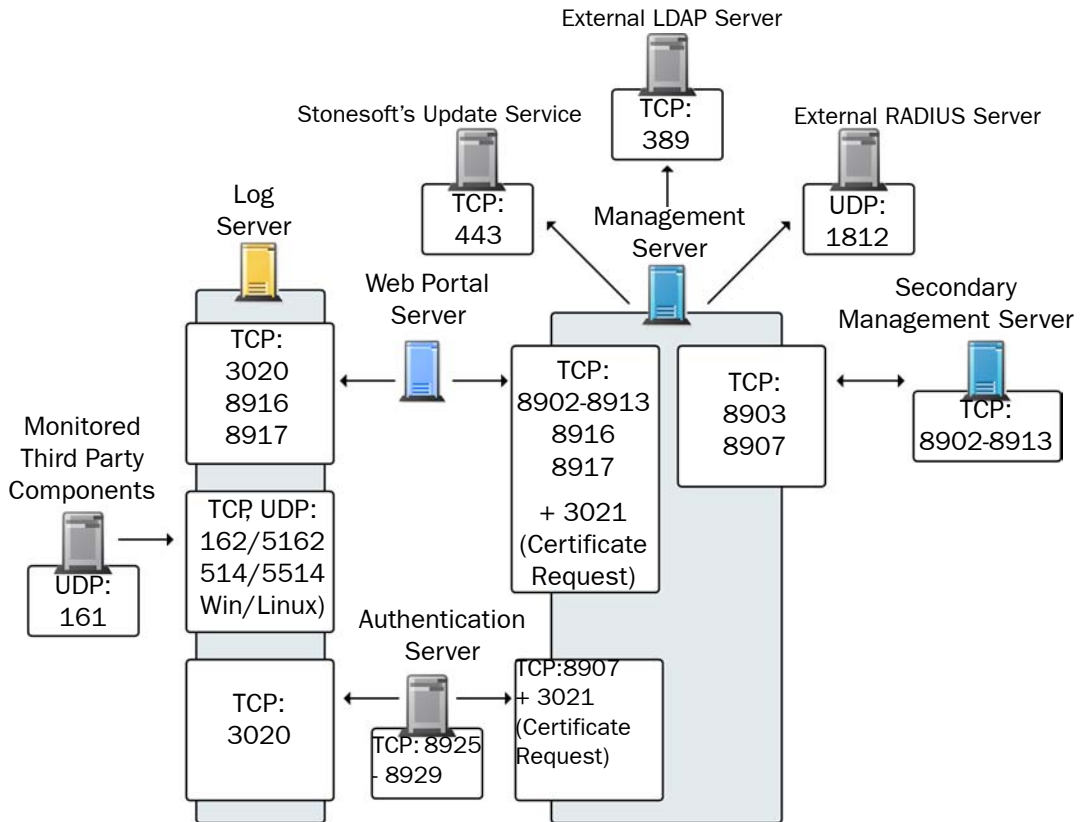

The table below lists all default ports SMC uses internally and with external components. Many of these ports can be changed. The name of corresponding default Service elements are also included for your reference. For information on communications between SMC components and the engines, see the separate listings.

**Table A.1 Management Center Default Ports**

<b>Listening Host</b>	<b>Port/Protocol</b>	<b>Contacting Hosts</b>	<b>Service Description</b>	<b>Service Element Name</b>
Authentication Server	8925-8929/TCP	Management Server	StoneGate Management Server commands to Authentication Server.	SG Authentication Commands
Authentication Server node	8988-8989/TCP	Authentication Server node	Data synchronization between Authentication Server nodes.	SG Authentication Sync
DNS server	53/UDP, 53/TCP	Management Client, Management Server, Log Server	DNS queries.	DNS (UDP)
LDAP server	389/TCP	Management Server	External LDAP queries for display/editing in the Management Client.	LDAP (TCP)
Log Server	162/UDP, 5162/UDP	Monitored third party components	SNMPv1 trap reception from third party components. Port 162 is used if installed on Windows, port 5162 if installed on Linux.	SNMP (UDP)
Log Server	514/TCP, 514/UDP, 5514/TCP, 5514/UDP	Monitored third party components	Syslog reception from third party components. Port 514 is used if installed on Windows, port 5514 if installed on Linux.	Syslog (UDP) [Partial match]
Log Server	3020/TCP	Authentication Server, Log Server, Web Portal Server	Alert sending.	SG Log
Log Server	8914-8918/TCP	Management Client	Log browsing.	SG Data Browsing
Log Server	8916-8917/TCP	Web Portal Server	Log browsing.	SG Data Browsing (Web Portal Server)
Management Server	3021/TCP	Log Server, Web Portal Server	System communications certificate request/renewal.	SG Log Initial Contact
Management Server	8902-8913/TCP	Management Client, Log Server, Web Portal Server	Monitoring and control connections.	SG Control
Management Server	8907/TCP	Authentication Server	Status monitoring.	SG Control

Table A.1 Management Center Default Ports (Continued)

Listening Host	Port/Protocol	Contacting Hosts	Service Description	Service Element Name
Monitored Third Party Components	161/UDP	Log Server	SNMP status probing to external IP addresses.	SNMP (UDP)
Primary Management Server	8903, 8907/TCP	Secondary Management Servers	Database replication (pull) to the secondary Management Server.	SG Control
RADIUS server	1812/UDP	Management Server	RADIUS authentication requests for administrator logins. The default ports can be modified in the properties of the RADIUS Server element.	RADIUS (Authentication)
Secondary Management Servers	8902-8913/TCP	Primary Management Server	Database replication (push) to the secondary Management Server.	SG Control
Stonesoft servers	443/TCP	Management Server	Update packages, engine upgrades, and licenses from update.stonesoft.com and smc.stonesoft.com.	HTTPS
Syslog Server	514/UDP, 5514/UDP	Log Server	Log data export to syslog servers. The default ports can be modified in the LogServerConfiguration.txt file.	Syslog (UDP) [Partial match]

## Firewall/VPN Engine Ports

The illustrations below present an overview to the most important default ports used in communications between firewall/VPN engines and the SMC and between clustered firewall engines. See the table below for a complete list of default ports for the fully-featured firewall/VPN engines.

Illustration A.3 Destination Ports for Basic Firewall/VPN Engine Communications

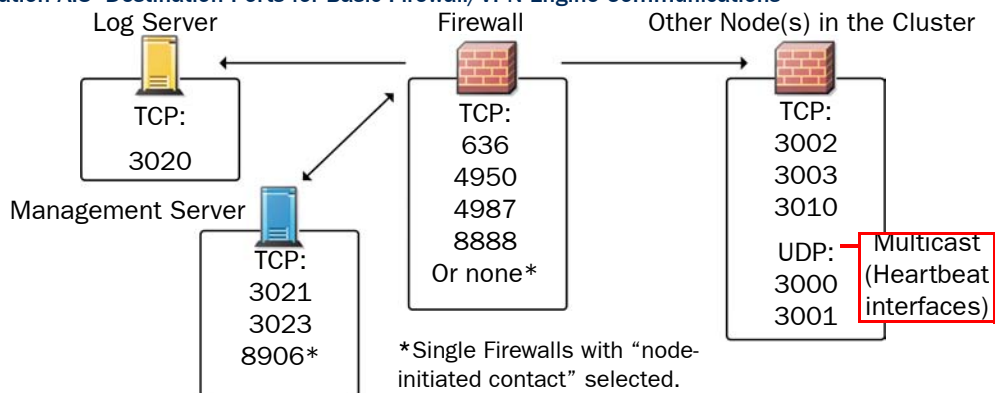

**Illustration A.4 Default Destination Ports for Firewall/VPN Engine Service Communications**

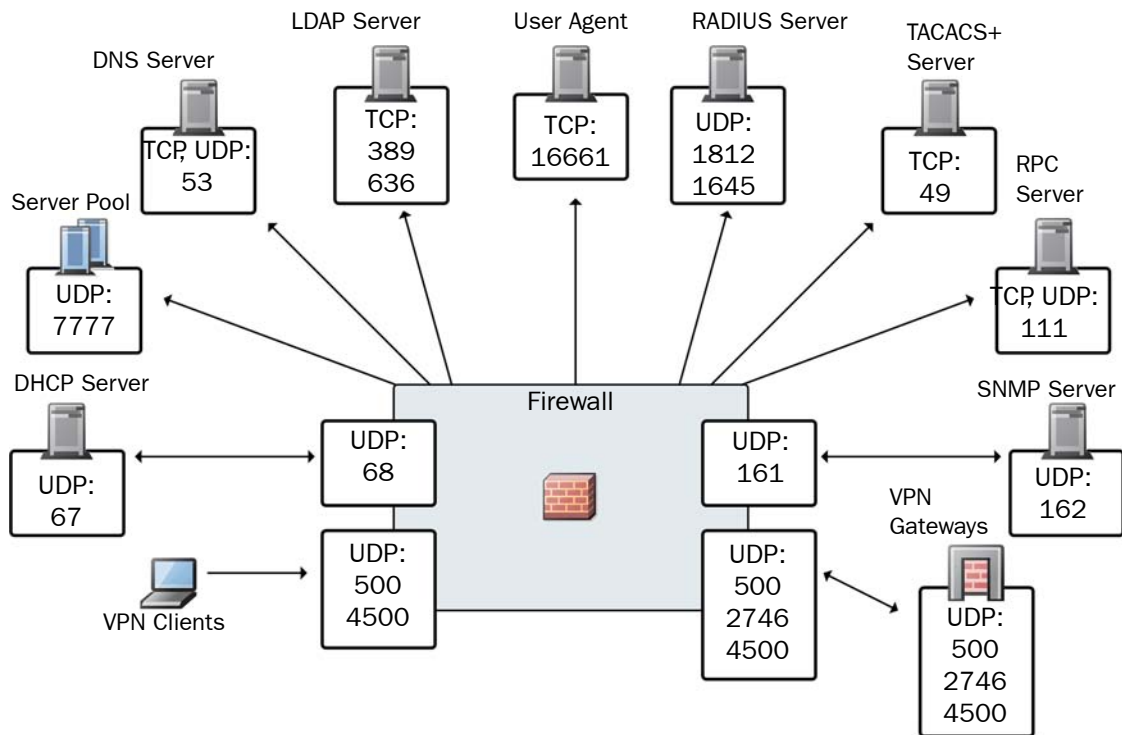

The table below lists all default ports StoneGate Firewall/VPN uses internally and with external components. Many of these ports can be changed. The name of corresponding default Service elements are also included for your reference.

**Table A.2 Firewall/VPN Default Ports**

Listening Host	Port/Protocol	Contacting Hosts	Service Description	Service Element Name
Anti-virus signature server	80/TCP	Firewall	Anti-virus signature update service.	HTTP
Authentication Server	8925-8929/TCP	Firewall	User directory and authentication services.	LDAP (TCP), RADIUS (Authentication)
BrightCloud Server	2316/TCP	Firewall	BrightCloud web filtering update service.	BrightCloud update
DHCP server	67/UDP	Firewall	Relayed DHCP requests and requests from a firewall that uses dynamic IP address.	BOOTPS (UDP)
DNS server	53/UDP, 53/TCP	Firewall	Dynamic DNS updates.	DNS (TCP)
Firewall	67/UDP	Any	DHCP relay on firewall engine.	BOOTPS (UDP)

**Table A.2 Firewall/VPN Default Ports (Continued)**

<b>Listening Host</b>	<b>Port/Protocol</b>	<b>Contacting Hosts</b>	<b>Service Description</b>	<b>Service Element Name</b>
Firewall	68/UDP	DHCP server	Replies to DHCP requests.	BOOTPC (UDP)
Firewall	161/UDP	SNMP server	SNMP monitoring.	SNMP (UDP)
Firewall	500/UDP	VPN clients, VPN gateways	VPN negotiations, VPN traffic.	ISAKMP (UDP)
Firewall	636/TCP	Management Server	Internal user database replication.	LDAPS (TCP)
Firewall	2543/TCP	Any	User authentication (Telnet) for Access rules.	SG User Authentication
Firewall	2746/UDP	StoneGate VPN gateways	UDP encapsulated VPN traffic.	SG UDP Encapsulation
Firewall	3000-3001/ UDP 3002-3003, 3010/TCP	FW/VPN engine	Heartbeat and state synchronization between clustered firewalls.	SG State Sync (Multicast), SG State Sync (Unicast), SG Data Sync
Firewall	4500/UDP	VPN client, VPN gateways	VPN traffic using NAT-traversal.	NAT-T
Firewall	4950/TCP	Management Server	Remote upgrade.	SG Remote Upgrade
Firewall	4987/TCP	Management Server	Management Server commands and policy upload.	SG Commands
Firewall	8888/TCP	Management Server	Connectivity monitoring; monitoring of blacklists, connections, and status for old engine versions.	SG Monitoring
Firewall	15000/TCP	Management Server, analyzer	Blacklist entries.	SG Blacklisting
LDAP server	389/TCP	Firewall	External LDAP queries, including StartTLS connections.	LDAP (TCP)
Log Server	3020/TCP	Firewall	Log and alert messages; monitoring of blacklists, connections, status, and statistics.	SG Log
Management Server	3021/TCP	Firewall	System communications certificate request/renewal (initial contact).	SG Initial Contact
Management Server	3023/TCP	Firewall	Monitoring (status) connection.	SG Reverse Monitoring

Table A.2 Firewall/VPN Default Ports (Continued)

Listening Host	Port/Protocol	Contacting Hosts	Service Description	Service Element Name
Management Server	8906/TCP	Firewall	Management connection for Single Firewalls with “node-initiated contact” selected.	SG Dynamic Control
RADIUS server	1812, 1645/UDP	Firewall	RADIUS authentication requests.	RADIUS (Authentication), RADIUS (Old)
RPC server	111/UDP, 111/TCP	Firewall	RPC number resolve.	SUNRPC (UDP), Sun RPC (TCP)
Server Pool Monitoring Agents	7777/UDP	Firewall	Polls to the servers’ Server Pool Monitoring Agents for availability and load information.	SG Server Pool Monitoring
SNMP server	162/UDP	Firewall	SNMP traps from the engine.	SNMP Trap (UDP)
TACACS+ server	49/TCP	Firewall	TACACS+ authentication requests.	TACACS (TCP)
User Agent	16661/TCP	Firewall	Queries for matching Users and User Groups with IP addresses.	SG Engine to User Agent
VPN gateways	500/UDP, 2746/UDP (StoneGate gateways only), or 4500 UDP	Firewall	VPN traffic. Ports 2746 and 4500 may be used depending on encapsulation options.	ISAKMP (UDP)

# IPS Engine Ports

The illustration below presents an overview to the most important default ports used in communications between IPS engines and the SMC and between clustered sensor engines. See the table below for a complete list of default ports.

**Illustration A.5 Default Destination Ports for Basic IPS System Communications**

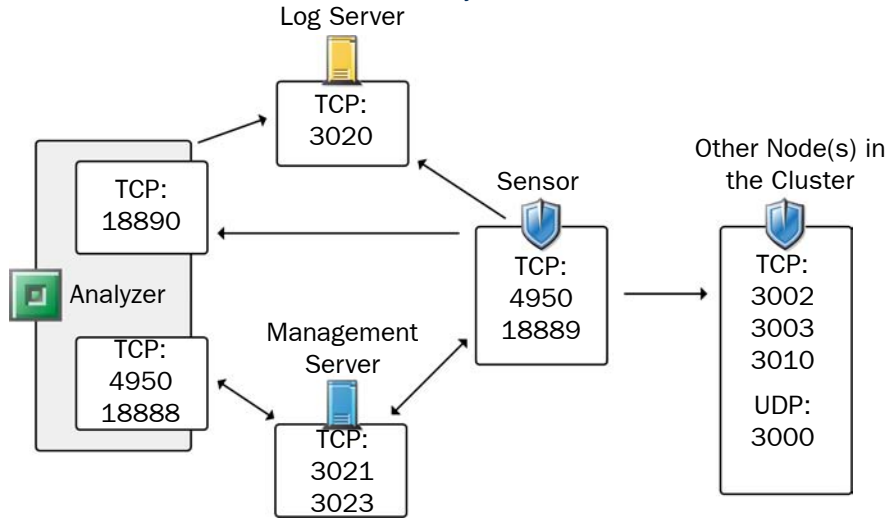

The table below lists all default ports StoneGate IPS uses internally and with external components. Many of these ports can be changed. The name of corresponding default Service elements are also included for your reference.

**Table A.3 IPS-Specific Ports**

Listening Hosts	Port/Protocol	Contacting Hosts	Service Description	Service Element Name
Analyzer	514/UDP	Syslog server	Syslog messages forwarded to Analyzer.	Syslog (UDP)
Analyzer	4950/TCP	Management Server	Remote upgrade.	SG Remote-Upgrade
Analyzer	18889/TCP	Management Server	Management connection.	SG Commands (Analyzer)
Analyzer	18890/TCP	Sensor	Event data sent from the Sensors.	SG Event Transfer
BrightCloud Server	2316/TCP	Sensor	BrightCloud web filtering update service.	BrightCloud update
Log Server	3020/TCP	Analyzer, Sensor	Log and alert messages from Analyzers; recording file transfers from Sensors; and monitoring of blacklists, status, and statistics from Sensors.	SG Log

Table A.3 IPS-Specific Ports (Continued)

Listening Hosts	Port/Protocol	Contacting Hosts	Service Description	Service Element Name
Management Server	3021/TCP	Sensor, analyzer	System communications certificate request/renewal (initial contact).	SG Initial Contact
Management Server	3023/TCP	Sensor, analyzer	Backup monitoring (status) connection.	SG Reverse Monitoring
Sensor	3000-3001/ UDP 3002,3003, 3010/TCP	Sensor	Heartbeat between the cluster nodes.	SG State Sync (Multicast), SG State Sync (Unicast), SG Data Sync
Sensor	4950/TCP	Management Server	Remote upgrade.	SG Remote Upgrade
Sensor	18888/TCP	Management Server	Management connection.	SG Commands (Sensor)
Sensor, firewall	15000/TCP	Management Server, analyzer, sensor	Blacklist entries.	SG Blacklisting



## APPENDIX B

# COMMAND LINE TOOLS

This appendix describes the command line tools for StoneGate Management Center and the engines.

The following sections are included:

- ▶ [Management Center Commands](#) (page 126)
- ▶ [Engine Commands](#) (page 135)
- ▶ [Server Pool Monitoring Agent Commands](#) (page 141)

# Management Center Commands

Management Center commands include commands for the Management Server, Log Server, Web Portal Server, and Authentication Server. Most of the commands are found in the `<installation directory>/bin/` directory. In Windows, the command line tools are \*.bat script files. In Linux, the files are \*.sh scripts.



**Note – Using the Management Client is the recommended configuration method, as most of the same tasks can be done through it.**

Commands that require parameters must be run through the command line (cmd.exe in Windows). Commands that do not require parameters can alternatively be run through a graphical user interface, and may be added as shortcuts during installation.

Table B.1 Management Center Command Line Tools

Command	Description
<pre>sgArchiveExport [ host=&lt;address&gt; ] [ login=&lt;login name&gt; ] pass=&lt;password&gt; [ format=CSV/XML/CEF ] i=&lt;input file&gt; [ o=&lt;output file&gt; ] [ f=&lt;filter file&gt; ] [ e=&lt;filter expression&gt; ] [ -h   -help ] [ -v ]</pre>	<p>Displays or exports logs from archive. This command is only available on the Log Server. The operation checks privileges for the supplied administrator account from the Management Server to prevent unauthorized access to the logs.</p> <p>Enclose details in double quotes if they contain spaces.</p> <p><b>Host</b> specifies the address of the Management Server. If the parameter is not defined, the loopback address is used.</p> <p><b>login</b> defines the username for the account that is used for this operation. If this parameter is not defined, the username root is used.</p> <p><b>pass</b> defines the password for the user account.</p> <p><b>format</b> defines the file format for the output file. If this parameter is not defined, the XML format is used.</p> <p><b>i</b> defines the source from which the logs will be exported. Can be a folder or a file. The processing recurses into subfolders.</p> <p><b>o</b> defines the destination file where the logs will be exported. If this parameter is not defined, the output is displayed on screen.</p> <p><b>f</b> defines a file that contains the filtering criteria you want to use for filtering the log data. You can export log filters individually in the Management Client through <b>Tools</b>→<b>Save for Command Line Tools</b> in the filter's right-click menu.</p> <p><b>e</b> allows you to type in a filter expression manually (using the same syntax as exported filter files).</p> <p><b>-h</b> or <b>-help</b> displays information on using the script.</p> <p><b>-v</b> displays verbose output on the command execution.</p> <p><b>Example</b> (exports logs from one full day to a file using a filter): sgArchiveExport login=admin pass=abc123 i=c:/stonesoft/stonegate/data/archive/firewall/ year2009/month12/day01/ f=c:/stonesoft/ stonegate/export/MyExportedFilter.flp format=CSV o=MyExportedLogs.csv</p>

Table B.1 Management Center Command Line Tools (Continued)

Command	Description
<b>sgBackupAuthSrv</b>	Creates a backup of Authentication Server user information. The backup file is stored in the <i>&lt;installation directory&gt;/backups/</i> directory. Backing up the Authentication only backs up Users, not the configuration of the Authentication Server. The Authentication Server configuration is included in the Management Server backup. Also see <b>sgRestoreAuthBackup</b> .
<b>sgBackupLogSrv</b>	Creates a backup of Log Server configuration data. The backup file is stored in the <i>&lt;installation directory&gt;/backups/</i> directory. Twice the size of log database is required on the destination drive. Otherwise, the operation fails. Also see <b>sgRestoreLogBackup</b> .
<b>sgBackupMgtSrv</b>	Creates a complete backup of the Management Server (including both the local configuration and the stored information in the configuration database). The backup file is stored in the <i>&lt;installation directory&gt;/backups/</i> directory. Twice the size of the Management Server database is required on the destination drive. Otherwise, the operation fails. Also see <b>sgRestoreMgtBackup</b> and <b>sgRecoverMgtDatabase</b> .
<b>sgCertifyAuthSrv</b>	Contacts the Management Server and creates a new certificate for the Authentication Server to allow secure communications with other system components. Renewing an existing certificate does not require changing the configuration of any other system components.
<b>sgCertifyLogSrv</b> [ <b>host</b> =<Management Server Address [\Domain]>]	Contacts the Management Server and creates a new certificate for the Log Server to allow secure communications with other system components. Renewing an existing certificate does not require changing the configuration of any other system components. <b>Host</b> specifies the address of the Management Server. If the parameter is not defined, the loopback address is used. <b>Domain</b> specifies the administrative Domain the Log Server belongs to if the system is divided in administrative Domains. If the Domain is not specified, the Shared Domain is used.
<b>sgCertifyMgtSrv</b>	Creates a new certificate for the Management Server to allow secure communications between the StoneGate system components. Renewing an existing certificate does not require changes on any other system components.

Table B.1 Management Center Command Line Tools (Continued)

Command	Description
<p><b>sgCertifyWebPortalSrv</b>  <b>[host=&lt;Management Server Address</b>  <b>[\Domain]&gt;]</b></p>	<p>Contacts the Management Server and creates a new certificate for the Web Portal Server to allow secure communications with other system components. Renewing an existing certificate does not require changing the configuration of any other system components.</p> <p><b>Host</b> specifies the address of the Management Server. If the parameter is not defined, the loopback address is used.</p> <p><b>Domain</b> specifies the administrative Domain the Web Portal Server belongs to if the system is divided in administrative Domains. If the Domain is not specified, the Shared Domain is used.</p>
<p><b>sgChangeMgtIPOnAuthSrv</b> &lt;IP address&gt;</p>	<p>Changes the Management Server's IP address in the Authentication Server's local configuration to the IP address you give as a parameter. Use this command if you change the Management Server's IP address. Restart the Authentication Server service after this command.</p>
<p><b>sgChangeMgtIPOnLogSrv</b> &lt;IP address&gt;</p>	<p>Changes the Management Server's IP address in the Log Server's local configuration to the IP address you give as a parameter. Use this command if you change the Management Server's IP address. Restart the Log Server service after this command.</p>
<p><b>sgChangeMgtIPOnMgtSrv</b> &lt;IP address&gt;</p>	<p>Changes the Management Server's IP address in the local configuration to the IP address you give as a parameter. Use this command if you change the Management Server's IP address. Restart the Management Server service after this command.</p>
<p><b>sgClient</b></p>	<p>Starts a locally installed StoneGate Management Client.</p>
<p><b>sgCreateAdmin</b></p>	<p>Creates an unrestricted (superuser) administrator account. The Management Server needs to be stopped before running this command.</p>

Table B.1 Management Center Command Line Tools (Continued)

Command	Description
<pre> <b>sgExport</b> [<b>host</b>=&lt;Management Server Address [\Domain]&gt;] [ <b>login</b>=&lt;login name&gt; ] <b>pass</b>=&lt;password&gt; <b>file</b>=&lt;file path and name&gt; <b>type</b>=&lt;all nw ips sv rb al&gt; [<b>-recursion</b>] [<b>-system</b>] [<b>name</b>= &lt;element name 1, element name 2, ...&gt;] </pre>	<p>Exports elements stored on the Management Server to an XML file.</p> <p>Enclose details in double quotes if they contain spaces.</p> <p><b>Host</b> specifies the address of the Management Server. If the parameter is not defined, the loopback address is used.</p> <p><b>Domain</b> specifies the administrative Domain for this operation if the system is divided in administrative Domains. If the Domain is not specified, the Shared Domain is used.</p> <p><b>login</b> defines the username for the account that is used for this operation. If this parameter is not defined, the username root is used.</p> <p><b>pass</b> defines the password for the user account.</p> <p><b>type</b> specifies which types of elements are included in the export file: <b>all</b> for all exportable elements, <b>nw</b> for network elements, <b>ips</b> for IPS elements, <b>sv</b> for services, <b>rb</b> for security policies, or <b>al</b> for alerts.</p> <p><b>recursion</b> includes referenced elements in the export, for example, the network elements used in a policy that you export.</p> <p><b>system</b> includes any system elements that are referenced by the other elements in the export.</p> <p><b>name</b> allows you to specify by name the element(s) that you want to export.</p>

Table B.1 Management Center Command Line Tools (Continued)

Command	Description
<pre> <b>sgHA</b> <b>host</b>=&lt;Management Server Address [\Domain]&gt; [ <b>login</b>=&lt;login name&gt; ] <b>pass</b>=&lt;password&gt; [ <b>-h</b>   <b>-help</b> ] [ <b>-set-active</b> ] [ <b>-set-standby</b> ] [ <b>-force-active</b> ] [ <b>-sync</b> ] </pre>	<p>Controls highly available (active and standby) Management Servers.</p> <p><b>Host</b> specifies the address of the Management Server. If the parameter is not defined, the loopback address is used.</p> <p><b>Domain</b> specifies the administrative Domain for this operation if the system is divided in administrative Domains. If the Domain is not specified, the Shared Domain is used.</p> <p><b>Login</b> defines the username for the account that is used for this operation. If this parameter is not defined, the username <code>root</code> is used.</p> <p><b>pass</b> defines the password for the user account.</p> <p><b>-h</b> or <b>-help</b> displays information on using the script.</p> <p><b>-set-active</b> sets a standby Management Server as the active Management Server, sets the formerly active Management Server as a standby Management Server, and synchronizes the database between them.</p> <p><b>-set-standby</b> sets the active Management Server as a standby Management Server.</p> <p><b>-force-active</b> sets a standby Management Server as the active Management Server without synchronizing the database with the formerly active Management Server.</p> <p><b>-sync</b> functions differently on a standby Management Server and an active Management Server. If you run it on an active Management Server, it replicates the active database to every standby Management Server that has the <b>Include in Database Replication</b> option selected in its properties. If you run it on a standby Management Server, it replicates the active database from the active Management Server only to this standby Management Server (regardless of whether the <b>Include in Database Replication</b> option is selected in the standby Management Server's properties).</p>
<pre> <b>sgImport</b> <b>host</b>=&lt;Management Server Address [\Domain]&gt; [ <b>login</b>=&lt;login name&gt; ] <b>pass</b>=&lt;password&gt; <b>file</b>=&lt;file path and name&gt; </pre>	<p>Imports StoneGate Management Server database elements from a StoneGate XML file. When importing, existing (non-default) elements are overwritten if both the name and type match.</p> <p><b>Host</b> specifies the address of the Management Server. If the parameter is not defined, the loopback address is used.</p> <p><b>Domain</b> specifies the administrative Domain for this operation if the system is divided in administrative Domains. If the Domain is not specified, the Shared Domain is used.</p> <p><b>Login</b> defines the username for the account that is used for this operation. If this parameter is not defined, the username <code>root</code> is used.</p> <p><b>pass</b> defines the password for the user account.</p> <p><b>file</b> defines the file whose contents you want to import.</p>

Table B.1 Management Center Command Line Tools (Continued)

Command	Description
<pre> <b>sgImportExportUser</b> <b>host</b>=&lt;Management Server Address [\Domain]&gt; [ <b>login</b>=&lt;login name&gt; ] <b>pass</b>=&lt;password&gt; <b>action</b>=[import export] <b>file</b>=&lt;file path and name&gt; </pre>	<p>Imports and exports a list of Users and User Groups in an LDIF file from/to a StoneGate Management Server's internal LDAP database. To import User Groups, all User Groups in the LDIF file must be directly under the <b>stonegate</b> top-level group (dc=stonegate).</p> <p><b>The user information in the export file is stored as plaintext. Handle the file securely.</b></p> <p><b>Host</b> specifies the address of the Management Server. If the parameter is not defined, the loopback address is used.</p> <p><b>Domain</b> specifies the administrative Domain for this operation if the system is divided in administrative Domains. If the Domain is not specified, the Shared Domain is used.</p> <p><b>login</b> defines the username for the account that is used for this operation. If this parameter is not defined, the username root is used.</p> <p><b>pass</b> defines the password for the user account.</p> <p><b>action</b> defines whether users are imported or exported.</p> <p><b>file</b> defines the file that is used for the operation.</p> <p><b>Example:</b> sgImportExportUser login=admin pass=abc123 action=export file=c:\temp\exportedusers.ldif</p>
<pre> <b>sgImportWebClientLanguage</b> <b>host</b>=&lt;Management Server Address [\Domain]&gt; [ <b>login</b>=&lt;login name&gt; ] <b>pass</b>=&lt;password&gt; <b>file</b>=&lt;file path and name&gt; </pre>	<p>Imports an additional language to the Web Portal end-user interface. You can run the command when the Web Portal Server service is running, but the imported language does not become available until the service is restarted.</p> <p><b>Host</b> specifies the address of the Management Server. If the parameter is not defined, the loopback address is used.</p> <p><b>Domain</b> specifies the administrative Domain for this operation if the system is divided in administrative Domains. If the Domain is not specified, the Shared Domain is used.</p> <p><b>login</b> defines the username for the account that is used for this operation. If this parameter is not defined, the username root is used.</p> <p><b>pass</b> defines the password for the user account.</p> <p><b>file</b> defines the file that is used for the operation. The imported file must use the UTF-8 or UTF-16 text encoding. The file name must follow the format messages_XX[_YY[_ZZ]].txt where XX is the two-character ISO language code, YY the ISO country code and ZZ the ISO language variant code. The country code and language variant code are optional.</p> <p><b>Example:</b> sgImportWebClientLanguage host=192.168.1.101/Helsinki login=ricky pass=abc123 file=messages_sv_fi.txt</p>

Table B.1 Management Center Command Line Tools (Continued)

Command	Description
<p><b>sgInfo</b></p>	<p>Creates a ZIP file that contains copies of configuration files and the system trace files. The resulting ZIP file is stored in the logged in user's home directory. The file location is displayed on the last line of screen output. Provide the generated file to Stonesoft support for troubleshooting purposes.</p>
<p><b>sgOnlineReplication</b> [-h --help]          [ login=&lt;login name&gt; ]          pass=&lt;password&gt;          active-server= &lt;name of active Management Server&gt;          standby-server= &lt;name of standby Management Server&gt;          standby-server-address= &lt;IP address of standby Management Server&gt;</p>	<p>Replicates the Management Server's database from the active Management Server to the standby Management Server.</p> <p><b>Note!</b> Use this script only if the secondary Management Server's configuration has been corrupted, the secondary Management Server's certificate has expired, or in new SMC installations if the automatic database replication between the Management Servers has not succeeded. Otherwise, synchronize the database through the Management Client (see <a href="#">Synchronizing Management Databases Manually</a> (page 293) or use the <b>sgHA</b> command.</p> <p><b>-h</b>   <b>--help</b> options display the help message</p> <p><b>pass</b> defines the password for the user account.</p> <p><b>active-server</b> option specifies the IP address of the active Management Server from which the Management database is replicated.</p> <p><b>standby-server</b> option specifies the name of the standby Management Server to which the Management database is replicated.</p> <p><b>standby-server-address</b> option specifies the IP address of the standby Management Server to which the Management database is replicated.</p>
<p><b>sgReinitializeLogServer</b></p>	<p>Located in &lt;installation directory&gt;/bin/install. Creates a new Log Server configuration if the configuration file has been lost.</p>
<p><b>sgRestoreArchive</b> ARCHIVE_DIR</p>	<p>Restores logs from archive files to the Log Server. This command is available only on the Log Server.</p> <p>ARCHIVE_DIR is the number of the archive directory (0 – 31) from where the logs will be restored. By default, only archive directory 0 is defined. The archive directories can be defined in the &lt;installation directory&gt;/data/LogServerConfiguration.txt file:          ARCHIVE_DIR_xx=PATH.</p>
<p><b>sgRestoreAuthBackup</b></p>	<p>Restores the Authentication Server user information from a backup file in the &lt;installation directory&gt;/backups/ directory.</p> <p>Apply the Authentication Server's configuration after this command.</p>

Table B.1 Management Center Command Line Tools (Continued)

Command	Description
<b>sgRestoreCertificate</b>	Restores the Certificate Authority (CA) or the Management Server certificate from a backup file in the <i>&lt;installation directory&gt;/backups/</i> directory.
<b>sgRestoreLogBackup</b>	Restores the Log Server (logs and/or configuration files) from a backup file in the <i>&lt;installation directory&gt;/backups/</i> directory.
<b>sgRestoreMgtBackup</b>	Restores the Management Server (database and/or configuration files) from a backup file in the <i>&lt;installation directory&gt;/backups/</i> directory.
<b>sgRevert</b>	<b>Note!</b> This script is located in the <i>&lt;installation directory&gt;/uninstall/</i> directory. Reverts to the previous installation saved during the upgrade process. The previous installation can be restored at any time, even after a successful upgrade.
<b>sgShowFingerPrint</b>	Displays the CA certificate's fingerprint on the Management Server.
<b>sgStartAuthSrv</b>	Starts the Authentication Server.
<b>sgStartLogDatabase</b>	Starts the Log Server's database. (The Log Server's database is started and stopped automatically when starting/stopping the Log Server service.)
<b>sgStartLogSrv</b>	Starts the Log Server and its database.
<b>sgStartMgtDatabase</b>	Starts the Management Server's database. There is usually no need to use this script.
<b>sgStartMgtSrv</b>	Starts the Management Server and its database.
<b>sgStartWebPortalSrv</b>	Starts the Web Portal Server.
<b>sgStopLogSrv</b>	Stops the Log Server.
<b>sgStopMgtSrv</b>	Stops the Management Server and its database.
<b>sgStopMgtDatabase</b>	Stops the Management Server's database. There is usually no need to use this script.
<b>sgStopWebPortalSrv</b>	Stops the Web Portal Server.
<b>sgStopRemoteMgtSrv</b> [ <b>host</b> =<Management Server Host Name>] [ <b>port</b> =<port number>] [ <b>login</b> =<login name>] [ <b>pass</b> =<password>]	Stops the Management Server service when run without arguments. To stop a remote Management Server service, provide the arguments to connect to the Management Server. <b>host</b> is the Management Server's host name if not localhost. <b>port</b> is the Management Server's Management Client port number (by default, 8902). <b>login</b> is a StoneGate administrator account for the login. <b>pass</b> is the password for the administrator account.

Table B.1 Management Center Command Line Tools (Continued)

Command	Description
<pre> <b>sgTextBrowser</b> <b>pass</b>=&lt;password&gt; [ <b>e</b>=&lt;filter expression&gt; ] [ <b>f</b>=&lt;filter file&gt; ] [ <b>format</b>=CSV/XML/CEF] [<b>host</b>=&lt;Management Server address [\Domain]&gt;] [<b>login</b>=&lt;login name&gt; ] [ <b>o</b>=&lt;output file&gt; ] [ <b>m</b>=current/stored ] [ <b>-v</b> ] [ <b>-h</b> ] </pre>	<p>Displays or exports current or stored logs. This command is available on the Log Server.</p> <p>Enclose the file and filter names in double quotes if they contain spaces.</p> <p>The <b>pass</b> parameter defines the password for the user account used for this operation.</p> <p>The <b>e</b> parameter defines the filter that you want to use for filtering the log data. Type the name as shown in the Management Client. The <b>f</b> parameter defines the StoneGate exported filter file that you want to use for filtering the log data.</p> <p>The <b>format</b> parameter defines the file format for the output file. If this parameter is not defined, the XML format is used.</p> <p>The <b>host</b> parameter defines the address of the Management Server used for checking the login information. If this parameter is not defined, Management Server is expected to be on the same host where the script is run. If Domains are in use, you can specify the Domain the Log Server belongs to. If domain is not specified, the Shared Domain is used.</p> <p>The <b>login</b> parameter defines the username for the account that is used for this export. If this parameter is not defined, the username <code>root</code> is used.</p> <p>The <b>o</b> parameter defines the destination output file where the logs will be exported. If this parameter is not defined, the output is displayed on screen.</p> <p>The <b>m</b> parameter defines whether you want to view or export logs as they arrive on the Log Server (current) or logs stored in the active storage directory (stored). If this option is not defined, the current logs are used.</p> <p>The <b>-h</b> option displays information on using the script.</p> <p>The <b>-v</b> option displays verbose output on command execution.</p>

# Engine Commands

The commands in the following two tables can be run on the command line on the analyzer, firewall, and/or sensor engines.

Table B.2 StoneGate-Specific Command Line Tools on Engines

Command	Engine Type	Description
<pre> <b>sg-blacklist</b> <b>show</b> [-v] [-f <i>FILENAME</i>]   <b>add</b> [ [-i <i>FILENAME</i>]   [src <i>IP_ADDRESS/MASK</i>] [dst <i>IP_ADDRESS/MASK</i>] [proto {<i>tcp/udp/icmp/NUM</i>}] [srcport <i>PORT</i>{-<i>PORT</i>}] [dstport <i>PORT</i>{-<i>PORT</i>}] [duration <i>NUM</i>] ]   <b>del</b> [ [-i <i>FILENAME</i>]   [src <i>IP_ADDRESS/MASK</i>] [dst <i>IP_ADDRESS/MASK</i>] [proto {<i>tcp/udp/icmp/NUM</i>}] [srcport <i>PORT</i>{-<i>PORT</i>}] [dstport <i>PORT</i>{-<i>PORT</i>}] [duration <i>NUM</i>] ]   <b>iddel</b> <i>NODE_ID ID</i>   <b>flush</b> </pre>	<p>firewall, sensor</p>	<p>Can be used to view, add, or delete active blacklist entries. The blacklist is applied as defined in Access Rules.</p> <p><b>Commands:</b></p> <p><b>show</b> displays the current active blacklist entries in format: engine node ID   blacklist entry ID   (internal)   entry creation time   (internal)   address and port match   originally set duration   (internal)   (internal). Use the <b>-f</b> option to specify a storage file to view (<code>/data/blacklist/db_&lt;number&gt;</code>). The <b>-v</b> option adds operation's details to the output.</p> <p><b>add</b> creates a new blacklist entry. Enter the parameters (see below) or use the <b>-i</b> option to import parameters from a file.</p> <p><b>del</b> deletes the first matching blacklist entry. Enter the parameters (see below) or use the <b>-i</b> option to import parameters from a file.</p> <p><b>iddel</b> <i>NODE_ID ID</i> removes one specific blacklist entry on one specific engine. <i>NODE_ID</i> is the engine's ID, <i>ID</i> is the blacklist entry's ID (as shown by the <b>show</b> command).</p> <p><b>flush</b> deletes all blacklist entries.</p> <p><b>Add/Del Parameters:</b></p> <p>Enter at least one parameter. The default value is used for the parameters that you omit. You can also save parameters in a text file; each line in the file is read as one blacklist entry.</p> <p><b>src</b> <i>IP_ADDRESS/MASK</i> defines the source IP address and netmask to match. Matches any IP address by default.</p> <p><b>dst</b> <i>IP_ADDRESS/MASK</i> defines the destination IP address and netmask to match. Matches any IP address by default.</p> <p><b>proto</b> {<i>tcp/udp/icmp/NUM</i>} defines the protocol to match by name or protocol number. Matches all IP traffic by default.</p> <p><b>srcport</b> <i>PORT</i>[-<i>PORT</i>] defines the TCP/UDP source port or range to match. Matches any port by default.</p> <p><b>dstport</b> <i>PORT</i>[-<i>PORT</i>] defines the TCP/UDP destination port or range to match. Matches any port by default.</p> <p><b>duration</b> <i>NUM</i> defines in seconds how long the entry is kept. Default is 0, which cuts current connections, but is not kept.</p> <p><b>Examples:</b></p> <pre> sg-blacklist add src 192.168.0.2/32 proto tcp dstport 80 duration 60 sg-blacklist add -i myblacklist.txt sg-blacklist del dst 192.168.1.0/24 proto 47 </pre>

Table B.2 StoneGate-Specific Command Line Tools on Engines (Continued)

Command	Engine Type	Description
<pre>sg-bootconfig [--primary-console=ttty0 tttyS PORT,SPEED] [--secondary-console=ttty0 tttyS PORT,SPEED] [--flavor=up smp] [--initrd=yes no] [--crashdump=yes no Y@X] [--append=kernel options] [--help] apply</pre>	<p>analyzer, firewall, sensor</p>	<p>Can be used to edit boot command parameters for future bootups.</p> <p><b>--primary-console=ttty0 tttyS PORT,SPEED</b> parameter defines the terminal settings for the primary console.</p> <p><b>--secondary-console=ttty0 tttyS PORT,SPEED</b> parameter defines the terminal settings for the secondary console.</p> <p><b>--flavor=up smp [-kdb]</b> parameter defines whether the kernel is uniprocessor or multiprocessor.</p> <p><b>--initrd=yes no</b> parameter defines whether Ramdisk is enabled or disabled.</p> <p><b>--crashdump=yes no Y@X</b> parameter defines whether kernel crashdump is enabled or disabled, and how much memory is allocated to the crash dump kernel (Y). The default is 24M. X must always be 16M.</p> <p><b>--append=kernel options</b> parameter defines any other boot options to add to the configuration.</p> <p><b>--help</b> parameter displays usage information.</p> <p><b>apply</b> command applies the specified configuration options.</p>
<pre>sg-clear-all</pre>	<p>analyzer, firewall, sensor</p>	<p><b>Use this only if you want to return a StoneGate appliance to its factory settings.</b></p> <p>Clears all configuration from the engine. You must have a local console connection to the engine to use this command.</p>
<pre>sg-cluster [status [-c SECONDS]] [online] [lock-online] [offline] [lock-offline] [standby] [safe-offline]</pre>	<p>firewall</p>	<p>Used to display or change the status of the node.</p> <p><b>status [-c SECONDS]</b> command displays cluster status. When <b>-c SECONDS</b> is used, status is shown continuously with the specified number of seconds between updates.</p> <p><b>online</b> command sends the node online.</p> <p><b>lock-online</b> command sends the node online and keeps it online even if another process tries to change its state.</p> <p><b>offline</b> command sends the node offline.</p> <p><b>lock-offline</b> command sends the node offline and keeps it offline even if another process tries to change its state.</p> <p><b>standby</b> command sets an active node to standby.</p> <p><b>safe-offline</b> command sets the node to offline only if there is another online node.</p>
<pre>sg-contact-mgmt</pre>	<p>analyzer, firewall, sensor</p>	<p>Used for establishing a trust relationship with the Management Server as part of engine installation or reconfiguration (see <i>sg-reconfigure</i> below). The engine contacts the Management Server using the one-time password created when the engine's initial configuration is saved.</p>

Table B.2 StoneGate-Specific Command Line Tools on Engines (Continued)

Command	Engine Type	Description
<pre>sg-dynamic-routing -start -stop -restart -force-reload -backup &lt;file&gt; -restore &lt;file&gt; -sample-config -route-table</pre>	firewall	<p>-start starts the Quagga routing suite.</p> <p>-stop stops the Quagga routing suite and flushes all routes made by zebra.</p> <p>-restart restarts the Quagga routing suite.</p> <p>-force-reload forces reload of the saved configuration.</p> <p>-backup &lt;file&gt; backs up the current configuration to a compressed file.</p> <p>-restore &lt;file&gt; restores the configuration from the specified file.</p> <p>-sample-config creates a basic configuration for Quagga.</p> <p>-route-table prints the current routing table.</p>
<pre>sg-ipsec -d [-u &lt;username[@domain]&gt;   -si &lt;session id&gt;   -ck &lt;ike cookie&gt;   -tri &lt;transform id&gt; -ri &lt;remote ip&gt;   -ci &lt;connection id&gt;]</pre>	firewall	<p>Deletes VPN-related information (use <code>vpninfo</code> command to view the information). Option <code>-d</code> (for delete) is mandatory.</p> <p><code>-u</code> deletes the VPN session of the named VPN client user. You can enter the user account in the form <code>&lt;username@domain&gt;</code> if there are several user storage locations (LDAP domains).</p> <p><code>-si</code> deletes the VPN session of a VPN client user based on session identifier.</p> <p><code>-ck</code> deletes the IKE SA (Phase one security association) based on IKE cookie.</p> <p><code>-tri</code> deletes the IPSEC SAs (Phase two security associations) for both communication directions based on transform identifier.</p> <p><code>-ri</code> deletes all SAs related to a remote IP address in gateway-to-gateway VPNs.</p> <p><code>-ci</code> deletes all SAs related to a connection identifier in gateway-to-gateway VPNs.</p>
<pre>sg-logger -f FACILITY_NUMBER -t TYPE_NUMBER [-e EVENT_NUMBER] [-i "INFO_STRING"] [-s] [-h]</pre>	analyzer, firewall, sensor	<p>Can be used in scripts to create log messages with the specified properties.</p> <p><code>-f FACILITY_NUMBER</code> parameter defines the facility for the log message.</p> <p><code>-t TYPE_NUMBER</code> parameter defines the type for the log message.</p> <p><code>-e EVENT_NUMBER</code> parameter defines the log event for the log message. The default is 0 (H2A_LOG_EVENT_UNDEFINED).</p> <p><code>-i "INFO_STRING"</code> parameter defines the information string for the log message.</p> <p><code>-s</code> parameter dumps information on option numbers to stdout</p> <p><code>-h</code> parameter displays usage information.</p>

Table B.2 StoneGate-Specific Command Line Tools on Engines (Continued)

Command	Engine Type	Description
<p><b>sg-raid</b>                      [-status] [-add] [-re-add]                      [-force] [-help]</p>	<p>analyzer,                      firewall,                      sensor</p>	<p>Configures a new hard drive. This command is only for StoneGate appliances that support RAID (Redundant Array of Independent Disks) and have two hard drives.</p> <p><b>-status</b> option displays the status of the hard drive.</p> <p><b>-add</b> options adds a new empty hard drive.</p> <p>Use <b>-add -force</b> if you want to add a hard drive that already contains data and you want to overwrite it.</p> <p><b>-re-add</b> adds a hard drive that is already partitioned. This command prompts for the drive and partition for each degraded array.</p> <p>Use <b>-re-add -force</b> if you want to check all the arrays.</p> <p><b>-help</b> option option displays usage information.</p>
<p><b>sg-reconfigure</b>                      [--boot]                      [--maybe-contact]                      [--no-shutdown]</p>	<p>analyzer,                      firewall,                      sensor</p>	<p>Used for reconfiguring the node manually.</p> <p><b>--boot</b> option applies bootup behavior. Do not use this option unless you have a specific need to do so.</p> <p><b>--maybe-contact</b> option contacts the Management Server if requested. This option is only available on firewall engines.</p> <p><b>--no-shutdown</b> option allows you to make limited configuration changes on the node without shutting it down. Some changes may not be applied until the node is rebooted.</p>
<p><b>sg-selftest</b> [-d] [-h]</p>	<p>firewall</p>	<p>Runs cryptography tests on the engine.</p> <p><b>-d</b> option runs the tests in debug mode.</p> <p><b>-h</b> option displays usage information.</p>
<p><b>sg-status</b> [-l] [-h]</p>	<p>analyzer,                      firewall,                      sensor</p>	<p>Displays information on the engine's status.</p> <p><b>-l</b> option displays all available information on engine status.</p> <p><b>-h</b> option displays usage information.</p>

Table B.2 StoneGate-Specific Command Line Tools on Engines (Continued)

Command	Engine Type	Description
<code>sg-toggle-active SHA1 SIZE   --force [--debug]</code>	analyzer, firewall, sensor	Switches the engine between the active and the inactive partition. This change takes effect when you reboot the engine. You can use this command, for example, if you have upgraded an engine and want to switch back to the earlier engine version. When you upgrade the engine, the active partition is switched. The earlier configuration remains on the inactive partition. To see the currently active (and inactive) partition, see the directory listing of <code>/var/run/stonegate</code> ( <code>ls-l /var/run/stonegate</code> ). The <code>SHA1 SIZE</code> option is used to verify the signature of the inactive partition before changing it to active. If you downgrade the engine, check the checksum and the size of the earlier upgrade package by extracting the signature and size files from the <code>sg_engine_[version.build]_i386.zip</code> file. <code>--debug</code> option reboots the engine with the debug kernel. <code>--force</code> option switches the active configuration without first verifying the signature of the inactive partition.
<code>sg-upgrade</code>	firewall	Upgrades the node by rebooting from the installation CD-ROM. Alternatively, the node can be upgraded remotely using the Management Client.
<code>sg-version</code>	analyzer, firewall, sensor	Displays the software version and build number for the node.
<code>sginfo</code> <code>[-f] [-d] [-s] [-p] [--] [--help]</code>	analyzer, firewall, sensor	Gathers system information you can send to Stonesoft support if you are having problems. Use this command only when instructed to do so by Stonesoft support. <code>-f</code> option forces <code>sgInfo</code> even if the configuration is encrypted. <code>-d</code> option includes core dumps in the <code>sgInfo</code> file. <code>-s</code> option includes slapcat output in the <code>sgInfo</code> file. <code>-p</code> option includes passwords in the <code>sgInfo</code> file (by default passwords are erased from the output). <code>--</code> option creates the <code>sgInfo</code> file without displaying the progress <code>--help</code> option displays usage information.

The table below lists some general operating system commands that may be useful in running your StoneGate engines. Some commands can be stopped by pressing `Ctrl+c`.

Table B.3 General Command Line Tools on Engines

Command	Description
<code>dmesg</code>	Shows system logs and other information. Use the <code>-h</code> option to see usage.

**Table B.3 General Command Line Tools on Engines (Continued)**

<b>Command</b>	<b>Description</b>
<b>halt</b>	Shuts down the system.
<b>ip</b>	Displays IP address information. Type the command without options to see usage. <b>Example:</b> type <b>ip addr</b> for basic information on all interfaces.
<b>ping</b>	Tests connectivity with ICMP echo requests. Type the command without options to see usage.
<b>ps</b>	Reports the status of running processes.
<b>reboot</b>	Reboots the system.
<b>scp</b>	Secure copy. Type the command without options to see usage.
<b>sftp</b>	Secure FTP. Type the command without options to see usage.
<b>ssh</b>	SSH client (for opening a terminal connection to other hosts). Type the command without options to see usage.
<b>tcpdump</b>	Gives information on network traffic. Use the <b>-h</b> option to see usage.
<b>top</b>	Displays the top CPU processes taking most processor time. Use the <b>-h</b> option to see usage.
<b>traceroute</b>	Traces the route packets take to the specified destination. Type the command without options to see usage.
<b>vpninfo</b>	Displays VPN information and allows you to issue some basic commands. Type the command without options to see usage.

# Server Pool Monitoring Agent Commands

You can test and monitor the Server Pool Monitoring Agents on the command line with the commands described in the table below.

Table B.4 Server Pool Monitoring Agent Commands

Command	Description
<code>sgagentd [-d]</code> <code>[-v level]</code> <code>[-c path]</code> <code>[test [files]]</code> <code>[syntax [files]]</code>	<p>Allows you to test different configurations before activating them.</p> <ul style="list-style-type: none"><li><code>-d</code> Don't Fork as a daemon. All log messages are printed to stdout or stderr only.</li><li><code>-v level</code> Set the verbosity level. The default level is 5. Levels 6-8 are for debugging where available.</li><li><code>-c path</code> Use the specified path as the first search directory for the configuration.</li></ul> <p><code>test [files]</code> Run in the test mode - status queries do not receive a response. If you specify the files, they are used for reading the configuration instead of the default files. The output is directed to syslog or eventlog instead of the console where the command was run unless you use the <code>-d</code> option.</p> <p><code>syntax [files]</code> Check the syntax in the configuration file. If no files are specified, the default configuration files are checked. The output is directed to syslog or eventlog instead of the console where the command was run unless you use the <code>-d</code> option.</p>

Table B.4 Server Pool Monitoring Agent Commands (Continued)

Command	Description
<pre> <b>sgmon</b> [<i>status/info/proto</i>] [-<i>p port</i>] [-<i>t timeout</i>] [-<i>a id</i>] <i>host</i> </pre>	<p>Sends a UDP query to the specified host and waits for a response until received, or until the timeout limit is reached.</p> <p>The request type can be defined as a parameter. If no parameter is given, <i>status</i> is requested. The commands are:</p> <p><i>status</i> - query the status.</p> <p><i>info</i> - query the agent version.</p> <p><i>proto</i> - query the highest supported protocol version.</p> <p>-<i>p port</i> Connect to the specified port instead of the default port.</p> <p>-<i>t timeout</i> Set the timeout (in seconds) to wait for a response.</p> <p>-<i>a id</i> Acknowledge the received log messages up to the specified <i>id</i>. Each response message has an <i>id</i>, and you may acknowledge more than one message at a given time by using the <i>id</i> parameter. Note that messages acknowledged by <i>sgmon</i> will no longer appear in the firewall logs.</p> <p><i>host</i></p> <p>The IP address of the host to connect to. To get the status locally, you may give <i>localhost</i> as the host argument. This parameter is mandatory.</p> <p><b>Return value:</b></p> <p>0 if the response was received</p> <p>1 if the query timed out</p> <p>-1 in case of an error</p>

## APPENDIX C

# PREDEFINED ALIASES

This appendix lists the predefined Aliases that exist in the system. The predefined Aliases are used in the Firewall's default system policies. Some of them may be useful when you create your own Firewall and IPS rules.

The following sections are included:

- ▶ [Pre-Defined User Aliases](#) (page 144)
- ▶ [System Aliases](#) (page 144)

# Pre-Defined User Aliases

User Aliases are usually created by administrators, but there are also some pre-defined user aliases in the system. User Aliases are preceded with one \$ character. The table below lists all the editable user Aliases automatically created by StoneGate Management Center. These Aliases are used in the firewalls' default DHCP Relay Sub-Policy.

**Table C.1 System-defined User Aliases**

Pre-Defined User Alias	Description
\$ DHCP address pools	Addresses that can be allocated by DHCP server(s).
\$ DHCP address pools for IPsec VPN Clients	Address pools for assigning virtual IP addresses to VPN clients.
\$ DHCP servers	All DHCP servers defined for the firewall.
\$ DHCP servers for IPsec VPN Clients	The DHCP servers defined for assigning virtual IP addresses to VPN clients.

# System Aliases

System Aliases are non-editable Aliases created by StoneGate. The System Aliases are preceded with two \$\$ characters. The table below lists the definitions of all the System Aliases. These Aliases are used in the firewall's default system policies.

**Table C.2 System Aliases**

System Alias	Description
\$\$ DHCP Enabled Interface Addresses	IP addresses (of CVIs on clusters) which have DHCP relay enabled.
\$\$ DHCP Enabled interface addresses for IPsec VPN clients	IP addresses (of NDIs on clusters) which have DHCP relay enabled for VPN Clients.
\$\$ DHCP Interface X.dns	IP address of the DHCP-assigned DNS server for interface number X.
\$\$ DHCP Interface X.gateways	IP address of the DHCP-assigned default router for interface number X.
\$\$ DHCP Interface X.ip	DHCP-assigned IP address for interface number X.
\$\$ DHCP Interface X.net	Network behind the dynamic IP interface number X.
\$\$ Interface ID X.ip	First IP address (CVI) of Physical Interface ID X.
\$\$ Interface ID X.net	Directly connected networks behind Physical Interface ID X.
\$\$ Local Cluster	All addresses of the cluster.
\$\$ Local Cluster (CVI addresses only)	All CVI addresses of the cluster.

**Table C.2 System Aliases (Continued)**

<b>System Alias</b>	<b>Description</b>
\$\$ Local Cluster (DHCP Interface Addresses)	All DHCP-assigned IP addresses of the engine.
\$\$ Local Cluster (NDI addresses only)	All NDI addresses of all nodes in the cluster.
\$\$ Local Cluster (NDI for heartbeat addresses only)	Heartbeat NDI addresses of all nodes in the cluster.
\$\$ Local Cluster (NDI for management addresses only)	Management NDI address(es) of all nodes in the cluster.
\$\$ Log Servers	IP addresses of all Log Servers.
\$\$ Management Servers	IP addresses of all Management Server.
\$\$ Valid DHCP Address Pools for IPsec VPN clients	Address pools defined for assigning virtual IP addresses to VPN clients.
\$\$ Valid DHCP Servers	All DHCP servers defined for the firewall.
\$\$ Valid DHCP Servers for IPsec VPN clients	The DHCP servers defined for assigning virtual IP addresses to VPN clients.



## APPENDIX D

# LOG FIELDS

The following sections are included:

- ▶ [Log Entry Fields](#) (page 148)
- ▶ [Facility Field Values](#) (page 169)
- ▶ [Type Field Values](#) (page 171)
- ▶ [Action Field Values](#) (page 172)
- ▶ [Event Field Values](#) (page 172)
- ▶ [IPsec VPN Log Messages](#) (page 177)
- ▶ [Audit Entry Types](#) (page 182)
- ▶ [Syslog Entries](#) (page 187)
- ▶ [Log Fields Controlled by the Additional Payload Option](#) (page 187)
- ▶ [Connection States](#) (page 188)

# Log Entry Fields

The following tables list the fields of the log entry table and the corresponding XML fields exported to syslog for exportable log entry fields. The rights of the administrator who views the logs and the log type(s) that the administrator has selected for viewing determine which fields are displayed.

- [Non-exportable Log Entry Fields](#) (page 148).
- [Exportable Alert Log Entry Fields](#) (page 152).
- [Exportable Alert Trace Log Entry Fields](#) (page 152).
- [Exportable Audit Log Entry Fields](#) (page 153).
- [Exportable Firewall Log Entry Fields](#) (page 154).
- [Exportable IPS Log Entry Fields](#) (page 156).
- [Exportable IPS Recording Log Entry Fields](#) (page 168).
- [Exportable SSL VPN Log Entry Fields](#) (page 169).

## Non-exportable Log Entry Fields

The following log entry fields can be displayed in the log table, but cannot be exported to syslog.

Table D.1 Non-exportable Log Entry Fields

Field	Description
Additional Situation	Identifier of an additional situation that was detected simultaneously with the situation that triggered the log event.
Blacklist response.Blacklist duration	Duration of blacklisting in seconds.
Blacklist response.Blacklist executor	Firewall or sensor that blacklisted the traffic that triggered the log event.
Blacklist response.Endpoint1 addr	Blacklisted IP addresses for Endpoint1.
Blacklist response.Endpoint1 mask	Netmask for blacklisted Endpoint1 IP address (32 = host address).
Blacklist response.Endpoint1 port	Blacklisted Endpoint1 port (empty = all ports).
Blacklist response.Endpoint1 port range	Blacklisted Endpoint1 port range.
Blacklist response.Endpoint2 addr	Blacklisted IP addresses for Endpoint2.
Blacklist response.Endpoint2 mask	Netmask for blacklisted Endpoint2 IP address (32 = host address).
Blacklist response.Endpoint2 port	Blacklisted Endpoint2 port (empty = all ports).

**Table D.1 Non-exportable Log Entry Fields (Continued)**

<b>Field</b>	<b>Description</b>
Blacklist response.Endpoint2 port range	Blacklisted Endpoint2 port range.
Blacklist response.Firewall ID	ID number of firewall node for which the blacklist request is assigned (this must match the Firewall ID given to the blacklist Analyzer module).
Blacklist response.IP Protocol	IP protocol of the blacklist response.
Blacklist response.Value missing in	Blacklist Response field for which value resolving failed.
Certificate verify error	TLS/SSL Certificate verify error code related to this event.
Correlation base component ID	The policy used to decide a response after successful correlation. Usually the value of this field is the same as "Component ID", and the field is omitted.
Data type	Data type of the log.
Element Domain	Administrative Domain of the element associated with the event.
Endpoint	The VPN Endpoint through which the traffic that triggered the log event was sent or received.
Ethernet main type	Ethernet frame main type (Ethernet 2, IPX, LLC, SNAP).
Event type	Description of the event triggered the log creation.
GRE protocol	Protocol number of the GRE payload packet.
GRE version	Version of the GRE header.
IP frag conflict range.IP frag different bytes	Total number of conflicting bytes.
IP frag conflict range.IP frag different bytes first	First conflicting byte in the IP fragment.
IP frag conflict range.IP frag different bytes last	Last conflicting byte in the IP fragment.
IP frag conflict range.IP frag different new first	Value of the first conflicting byte in the latest fragment.
IP frag conflict range.IP frag different new last	Value of the last conflicting byte in the latest fragment.
IP frag conflict range.IP frag different old first	Value of the first conflicting byte in an earlier fragment.
IP frag conflict range.IP frag different old last	Value of the last conflicting byte in an earlier fragment.

**Table D.1 Non-exportable Log Entry Fields (Continued)**

<b>Field</b>	<b>Description</b>
IPv6 extension header type	IPv6 extension header type as indicated by the next header value of the preceding header.
IPv6 extension header's length	IPv6 extension header length as indicated by the value of the <code>hdr_ext_len</code> field in the extension header.
IPv6 hop limit	Hop limit field in the IPv6 header.
IPv6 option data length	IPv6 option data length.
IPv6 option offset	IPv6 option offset from the beginning of the IPv6 extension header.
IPv6 option type	IPv6 option type.
IPv6 routing final destination	Final destination address in the IPv6 routing header.
IPv6 routing header type	IPv6 routing header type.
IPv6 routing segments left	Segments left value in the IPv6 routing header.
LLC DSAP	Logical Link Control Destination Service Access Point.
LLC SSAP	Logical Link Control Source Service Access Point.
Login Domain	The administrative Domain in which the action that triggered the log event was taken.
Normalized	URI normalization was used to find the match.
Overview	Observed overview.
Overview Name	Name of the observed overview.
Overview Section	Summary of the observed section definition.
Reference event ID.Ref Comp Id	Sender identifier of the referred event.
Reference event ID.Ref Creation Time	Creation time of the referred event.
Reference event ID.Ref Event ID	Identifier of the referred event.
Roles	Roles of the Administrator who triggered the event.
Security Gateway	The VPN Security Gateway through which the traffic that triggered the log event was sent or received.
Sender Domain	Administrative Domain from which the log entry was sent.
Sender module version.Sender build	Build number of the engine that generated the event.
Sender module version.Sender module major	Major version of the engine module that generated the event.

**Table D.1 Non-exportable Log Entry Fields (Continued)**

<b>Field</b>	<b>Description</b>
Sender module version.Sender module minor	Minor version of the engine module that generated the event.
Sender module version.Sender module pl	Patch version of the engine module that generated the event.
SNAP Organization Code	Subnetwork Access Protocol Organization Code.
SSL/TLS Domain	Domain name field in SSL/TLS certificate related to the event.
State	Connection state in connection monitoring.
Subexpression Count	The number of concurrent independent subexpressions.
TCP urgent pointer	Urgent pointer value in the TCP header.
TCP window size	TCP receive window size.
TCP window shrinkage	The amount by which the TCP window shrunk.
Threshold Check Time	Threshold measurement end time.
Threshold Description	Description of threshold limitation.
Threshold Measured Value	Value exceeding the threshold.
TLS Alert Description	TLS/SSL alert message description.
TLS Alert Level	TLS/SSL alert message alert level.
TLS cipher suite	TLS/SSL cipher suite.
TLS compression method	TLS/SSL compression method.
TLS Protocol Version	TLS/SSL protocol version.
Tunneling level	Number of tunneling protocol layers encapsulating this protocol layer.
User and Group Information	User and Group Information related to the event.
Virus Identifier	Virus Identifier.
VPN	The VPN through which the traffic that triggered the log event was sent or received.

## Exportable Alert Log Entry Fields

Table D.2 Alert Log Entry Fields

Field	Syslog Export Field	Description
Acknowledged	ACK	Acknowledged alert.
Alert Type	ALERT	Type of alert.
Component ID	COMP_ID	The identifier of the creator of the log entry.
Creation Time	TIMESTAMP	Log entry creation time.
Data Identifier	LOG_ID	Data Identifier of the log entry.
Description	LONG_MSG	Long field description of the alert.
Dst Addr	DST	Packet destination IP address.
Event ID	EVENT_ID	Event identifier, unique within one sender.
Information message	INFO_MSG	A description of the log event that further explains the entry.
Protocol	PROTOCOL	Connection IP protocol.
Reception time	RECEPTION_TIME	Time when the entry was received by the Log Server.
Reference event ID	REF_EVENT	Reference to a related event.
Rule Tag	RULE_ID	Rule tag of the rule that triggered the log event.
Sender	NODE_ID	IP address of the engine or server that sent the log entry.
Sender type	SENDER_TYPE	The type of engine or server that sent the log entry.
Severity	ALERT_SEVERITY	Severity of the situation related to the alert event.
Situation	SITUATION	The identifier of the situation that triggered the log event.
Situation Type	SIT_CATEGORY	The type of the situation that triggered the log event.

## Exportable Alert Trace Log Entry Fields

Table D.3 Alert Trace Log Entry Fields

Field	Syslog Export Field	Description
Address	EVENT_ADDRESS	Destination for the alert notification.
Alert Event	EVENT_TYPE	Type of alert event.
Alert Identifier	EVENT_LOG_ID	Data Identifier of the alert.
Alert Time	EVENT_TIME	Timestamp of the alert.

**Table D.3 Alert Trace Log Entry Fields (Continued)**

<b>Field</b>	<b>Syslog Export Field</b>	<b>Description</b>
Component ID	COMP_ID	The identifier of the creator of the log entry.
Creation Time	TIMESTAMP	Log entry creation time.
Data Identifier	LOG_ID	Data Identifier of the log entry.
Event description	EVENT_INFO	Description of the alert event.
Storage Server	STORAGE_SERVER_ID	Server where the alert is stored.
User	EVENT_USER	User who executed the action that produced the alert.

## **Exportable Audit Log Entry Fields**

**Table D.4 Audit Log Entry Fields**

<b>Field</b>	<b>Syslog Export Field</b>	<b>Description</b>
Administrator	USER_ORIGINATOR	Administrator who triggered the audit event.
Client IP address	CLIENT_IP_ADDRESS	Address of the client that triggered the audit event.
Component ID	COMP_ID	The identifier of the creator of the log entry.
Creation Time	TIMESTAMP	Log entry creation time.
Elements	OBJECT_NAME	Elements being manipulated in the audit event.
Event ID	EVENT_ID	Event identifier, unique within one sender.
Incident case	INCIDENT_CASE	The Incident case to which the logs and/or audit events are related.
Information message	INFO_MSG	A description of the log event that further explains the entry.
Operation type	TYPE_DESCRIPTION	Type of action that triggered the audit entry.
Origin name	ORIGIN_NAME	Name of the component that triggered the audit event.
Result	RESULT	Result state after the audited event.
Sender	NODE_ID	IP address of the engine or server that sent the log entry.
Sender type	SENDER_TYPE	The type of engine or server that sent the log entry.

# Exportable Firewall Log Entry Fields

Table D.5 Firewall Log Entry Fields

Field	Syslog Export Field	Description
Acknowledged	ACK	Acknowledged alert.
Action	ACTION	Action of the rule that triggered the log event. The action values are Allow, Discard, Refuse, Terminate, Wait for further actions, and Wait for authentication. For more information on action values, see the table <a href="#">Event Field Values</a> (page 172).
Alert Type	ALERT	Type of alert.
Auth. Rule Tag	AUTH_RULE_ID	Rule number of the rule that triggered the log event.
Auth. User	AUTH_NAME	Username of the authorized user related to this event.
Bytes Rcvd	ACC_RX_BYTES	Number of bytes received during the connection.
Bytes Sent	ACC_TX_BYTES	Number of bytes sent during the connection. The number of bytes sent is counted when accounting entries are created.
Component ID	COMP_ID	The identifier of the creator of the log entry.
Creation Time	TIMESTAMP	Log entry creation time.
Data Identifier	LOG_ID	Data Identifier of the log entry.
DSCP Mark	DSCP_MARK	The DSCP Mark associated with the traffic that triggered the log event.
Dst Addr	DST	Packet destination IP address.
Dst Port	DPORT	TCP or UDP destination port in the packet header.
Elapsed Time	ACC_ELAPSED	Elapsed time of the connection in seconds. The elapsed time is recorded when accounting entries are created at the time of connection closing.
Event	EVENT	The event that triggered the log creation, for example, New connection, Connection closed, Connection discarded. For more information on event values, see the table <a href="#">Event Field Values</a> (page 172).
Event ID	EVENT_ID	Event identifier, unique within one sender.
Facility	FACILITY	Firewall subsystem that generated the log event. For more information on facility values, see the table <a href="#">Facility Field Values</a> (page 169).
FP situation	FP_SITUATION	Situation identifier of a matching fingerprint.
ICMP code	ICMP_CODE	ICMP code field. ICMP code provides further information about message type (for example, network unreachable). For more information, refer to <i>RFC 792</i> and <i>RFC 950</i> .

**Table D.5 Firewall Log Entry Fields (Continued)**

<b>Field</b>	<b>Syslog Export Field</b>	<b>Description</b>
ICMP ID	ICMP_ID	The ICMP identifier recorded by the engine when ICMP packets pass through the firewall. The ICMP identifier may be used by the echo sender to aid in matching the replies with the echo requests. For example, the identifier might be used like a port in TCP or UDP to identify a session. For more information on ICMP ID and the ICMP protocol, refer to <i>RFC 792</i> and <i>RFC 950</i> .
IKE Cookie	IKE_COOKIE	IKE Cookie used in the VPN negotiation.
Information message	INFO_MSG	A description of the log event that further explains the entry.
IPsec SPI	IPSEC_SSPI	The IPsec Security Parameter Index (SPI) is the connection identifier of the IPsec connection. The IPsec SPI value is displayed as a hexadecimal number.
NAT Dst	NAT_DST	Translated packet destination IP address.
NAT Dst Port	NAT_DPORT	Translated packet destination protocol port.
Nat Rule Tag	NAT_RULE_ID	The rule number of the NAT rule that triggered the log event.
NAT Src	NAT_SRC	Translated packet source IP address.
NAT Src Port	NAT_SPORT	Translated packet source protocol port.
Priority	QOS_PRIORITY	The priority assigned to the traffic according to the QoS policy.
Protocol	PROTOCOL	Connection IP protocol.
Protocol Agent	SRVHELPER_ID	Protocol Agent numerical ID code.
QoS Class	QOS_CLASS	The Quality of Service class assigned to the traffic according to the QoS policy.
Reception time	RECEPTION_TIME	Time when the entry was received by the Log Server.
Reference event ID	REF_EVENT	Reference to a related event.
Round trip	RTT	Round trip time for outbound Multi-Link link testing. Time indicated is from sending queries to the first reply. The unit is 0.01 seconds.
Rule Tag	RULE_ID	Rule tag of the rule that triggered the log event.
Sender	NODE_ID	IP address of the engine or server that sent the log entry.
Sender type	SENDER_TYPE	The type of engine or server that sent the log entry.
Service	SERVICE	Special field for filtering logs using the defined services. Does not appear in the log entry table.

**Table D.5 Firewall Log Entry Fields (Continued)**

Field	Syslog Export Field	Description
Severity	ALERT_SEVERITY	Severity of the situation related to the log event.
Situation	SITUATION	The identifier of the situation that triggered the log event.
Situation Type	SIT_CATEGORY	The type of the situation that triggered the log event.
Src Addr	SRC	Packet source IP address.
Src IF	Srcif	Defined source interface number for the firewall cluster.
Src Port	SPORT	TCP or UDP source port in the packet header.
Src VLAN	SRC_VLAN	The source VLAN ID number (up to 4095).
Syslog	SYSLOG_TYPE	Syslog is a system service used in some operating systems, e.g., UNIX- and software packages. For more information on syslog and syslog types, refer to <i>RFC 3164</i> .
Type	TYPE	Log entry severity type. For more information on type values, see the table <a href="#">Type Field Values</a> (page 171).

## Exportable IPS Log Entry Fields

**Table D.6 IPS Log Entry Fields**

Field	Syslog Export Field	Description
Agent mem usage	AGENT_MEMUSAGE	Memory usage of each IPS agent.
Alert Type	ALERT	Type of alert.
Attacker IP	IP_ATTACKER	IPv4 address of the attacking host.
Blacklist executor	FIREWALL_ID	Firewall that blacklisted the traffic that triggered the log event.
Blacklist response	BLACKLIST_RESPONSE	Firewall blacklist response that triggered the log event.
Cluster ID	CLUSTER_ID	The identifier of the cluster to which the node that created the log entry belongs.
Component ID	COMP_ID	The identifier of the creator of the log entry.
Connection analysis end	CONNECTION_ANALYSIS_END	The application could not continue analyzing the traffic stream after this event.
Connection dropped	DROP_CONNECTION	The connection was dropped by a Drop Response in the rule.
Content type of message body	SIP_CONTENT_TYPE	Content type of the SIP message body.
Correlation base component ID	CORRELATION_COMP_ID	The policy that decides the response after successful correlation.

**Table D.6 IPS Log Entry Fields (Continued)**

<b>Field</b>	<b>Syslog Export Field</b>	<b>Description</b>
Correlation begin time	TIME_FRAME_BEGIN	NTP stamp of the beginning of the time frame for a match to a correlation situation.
Correlation end time	TIME_FRAME_END	NTP stamp of the end of the time frame for a match to a correlation situation.
Creation Time	TIMESTAMP	Log entry creation time.
Data Identifier	LOG_ID	Data Identifier of the log entry.
Datagram dropped	DROP_DATAGRAM	The datagram was dropped by a Drop Response in the rule.
Description	LONG_MSG	Long field description of the alert.
Destination port	PORT_DEST	TCP or UDP destination port in the packet header. Included only for backwards compatibility with legacy IPS engines. For other cases, use Dst Port.
DNS class	DNS_CLASS	DNS resource record class.
DNS hdr ancourt	DNS_HDR_ANCOUNT	DNS answers count.
DNS hdr arcourt	DNS_HDR_ARCOUNT	DNS additional section count.
DNS hdr flag tc	DNS_HDR_FLAG_TC	DNS header flag TC.
DNS hdr id	DNS_HDR_ID	DNS message ID.
DNS hdr is request	DNS_HDR_IS_REQUEST	DNS message is a request.
DNS hdr nscount	DNS_HDR_NS_COUNT	DNS authority section count.
DNS hdr opcode	DNS_HDR_OPCODE	DNS operation code.
DNS hdr qdcount	DNS_HDR_QDCOUNT	DNS questions count.
DNS hdr rcode	DNS_HDR_RCODE	DNS return code.
DNS name length	DNS_NAME_LENGTH	Length of DNS name in a message.
DNS offset	DNS_OFFSET	DNS message offset where the situation occurs.
DNS pointer	DNS_POINTER	Name pointer in a DNS message.
DNS qclass	DNS_QCLASS	Query resource record class in a DNS message.
DNS qname	DNS_QNAME	First queried name in a DNS message.
DNS qtype	DNS_QTYPE	Query type in a DNS message.
DNS section	DNS_SECTION	Section name in a DNS message.
DNS type	DNS_TYPE	DNS resource record type.
DNS UDP payload	DNS_UDP_PAYLOAD	UDP payload size of a DNS message.

**Table D.6 IPS Log Entry Fields (Continued)**

<b>Field</b>	<b>Syslog Export Field</b>	<b>Description</b>
DNS UDP payload by opt	DNS_UDP_PAYLOAD_BY_OPT	UDP payload advertised in a DNS OPT record.
Dst Addr	DST	Packet destination IP address.
Dst Port	DPORT	TCP or UDP destination port in the packet header.
Error id	ERROR_ID	Identifier of the error that triggered the log event.
Eth frame length	ETH_FRAME_LENGTH	Length of the Ethernet frame.
Eth min frame length	ETH_MIN_FRAME_LENGTH	Minimum length for Ethernet frame.
Ethernet type	ETH_TYPE	Type field in Ethernet frame.
Event count	EVENT_COUNT	Event count in the defined time frame.
Event ID	EVENT_ID	Event identifier, unique within one sender.
Event update	EVENT_UPDATE	Event ID for which this event is an update.
Excerpt data	EXCERPT	Short recording of the application level data stream of the attack.
Excerpt position	EXCERPT_POS	Position in the attached short recording.
Failed response cnt	FAILED_RESP_CNT	Number of failed response attempts.
Fields updatable	FIELDS_UPDATABLE	Map of updatable log fields.
FP situation	FP_SITUATION	Situation identifier of a matching fingerprint.
Frame dropped	DROP_FRAME	The frame was dropped by a Drop Response in the rule.
From address	SIP_FROM	SIP From address.
FTP account len	FTP_ACCOUNT_LEN	Length of the FTP account string.
FTP adat argument len	FTP_ADAT_ARG_LEN	Length of ADAT command argument.
FTP allocate size	FTP_ALLOCATE_SIZE	Size of FTP allocate.
FTP arg len	FTP_ARG_LEN	Length of the FTP command argument.
FTP auth arg len	FTP_AUTH_ARG_LEN	Length of the AUTH argument.
FTP client state name	FTP_CLIENT_STATE_NAME	The detected FTP client state.
FTP clnt arg len	FTP_CLNT_ARG_LEN	Length of the FTP CLNT argument.
FTP command	FTP_COMMAND	Name of the FTP command.

**Table D.6 IPS Log Entry Fields (Continued)**

<b>Field</b>	<b>Syslog Export Field</b>	<b>Description</b>
FTP conf arg len	FTP_CONF_ARG_LEN	Length of the CONF command argument.
FTP enc arg len	FTP_ENC_ARG_LEN	Length of the ENC command argument.
FTP eprt arg len	FTP_EPRT_ARG_LEN	Length of the EPRT command argument.
FTP estp arg len	FTP_ESTP_ARG_LEN	Length of the ESTP command argument.
FTP help arg len	FTP_HELP_ARG_LEN	Length of the HELP command argument.
FTP lang arg len	FTP_LANG_ARG_LEN	Length of the LANG command argument.
FTP lpvt arg len	FTP_LPRT_ARG_LEN	Length of the LPRT command argument.
FTP marker len	FTP_MARKER_LEN	Length of the REST command argument.
FTP mic arg len	FTP_MIC_ARG_LEN	Length of the MIC command argument.
FTP opts arg len	FTP_OPTS_ARG_LEN	Length of the OPTS command argument.
FTP password len	FTP_PASSWORD_LEN	Length of the detected FTP password.
FTP pathname len	FTP_PATHNAME_LEN	Length of the detected FTP pathname.
FTP protection buffer size	FTP_PROTECTION_BUFFER_SIZE	Size of the detected PBSZ protection buffer.
FTP reply	FTP_REPLY	The detected FTP server reply.
FTP reply code	FTP_REPLY_CODE	The detected FTP server reply code.
FTP reply len	FTP_REPLY_LEN	Length of an FTP server reply that is too long.
FTP reply line len	FTP_REPLY_LINE_LEN	Length of an FTP server reply line that is too long.
FTP server action	FTP_SERVER_ACTION	FTP server action after a suspicious client command.
FTP server banner	FTP_SERVER_BANNER	The detected FTP server banner.
FTP server state name	FTP_SERVER_STATE_NAME	The detected FTP server state.
FTP site arg len	FTP_SITE_ARG_LEN	Length of the SITE command argument.
FTP state name	FTP_STATE_NAME	The detected FTP session state.
FTP username len	FTP_USERNAME_LEN	Length of the detected FTP username.
HTTP content length	HTTP_CONTENT_LENGTH	HTTP content length.
HTTP content type	HTTP_CONTENT_TYPE	HTTP content type.
HTTP header	HTTP_HEADER	The detected HTTP header field.

**Table D.6 IPS Log Entry Fields (Continued)**

<b>Field</b>	<b>Syslog Export Field</b>	<b>Description</b>
HTTP header name	HTTP_HEADER_NAME	The detected HTTP header field name.
HTTP no request	HTTP_NO_REQUEST	The detected HTTP response could not be associated to any request.
HTTP request host	HTTP_REQUEST_HOST	HTTP request host.
HTTP request line	HTTP_REQUEST_LINE	The detected HTTP request line.
HTTP request message field name length	HTTP_REQUEST_MESSAGE_FIELD_NAME_LENGTH	Length of the HTTP request header field name.
HTTP request message field value length	HTTP_REQUEST_MESSAGE_FIELD_VALUE_LENGTH	Length of the HTTP request header field value.
HTTP request method	HTTP_REQUEST_METHOD	The detected HTTP request method.
HTTP request URI	HTTP_REQUEST_URI	The detected HTTP request URI.
HTTP request version	HTTP_REQUEST_VERSION	The detected HTTP request version.
HTTP requests not stored	HTTP_REQUESTS_NOT_STORED	Number of requests not stored due to HTTP pipeline overflow.
HTTP response code	HTTP_RESPONSE_CODE	The detected HTTP response code.
HTTP response message field name length	HTTP_RESPONSE_MESSAGE_FIELD_NAME_LENGTH	Length of the HTTP response header field name.
HTTP response message field value length	HTTP_RESPONSE_MESSAGE_FIELD_VALUE_LENGTH	Length of the HTTP response header field value.
HTTP URI length	HTTP_URI_LENGTH	Length of HTTP request URI
ICMP code	ICMP_CODE	ICMP code field. ICMP code provides further information about message type (for example, network unreachable). For more information, refer to <i>RFC 792</i> and <i>RFC 950</i> .
ICMP expected message length	ICMP_EXPECTED_MESSAGE_LENGTH	Expected length of the ICMP message.
ICMP field addr entry size	ICMP_FIELD_ADDR_ENTRY_SIZE	Value of the detected ICMP address entry size field.
ICMP field address mask	ICMP_FIELD_ADDRESS_MASK	Value of detected ICMP address mask field.

**Table D.6 IPS Log Entry Fields (Continued)**

<b>Field</b>	<b>Syslog Export Field</b>	<b>Description</b>
ICMP field domain name	ICMP_FIELD_DOMAIN_NAME	Value of the detected ICMP domain name field.
ICMP field gateway IP addr	ICMP_FIELD_GATEWAY_IP_ADDR	Value of the detected ICMP gateway address field.
ICMP field lifetime	ICMP_FIELD_LIFETIME	Value of the ICMP lifetime field.
ICMP field num addrs	ICMP_FIELD_NUM_ADDRS	Value of the ICMP number of addresses field.
ICMP field originate timestamp	ICMP_FIELD_ORIGINATE_TIMESTAMP	Value of the ICMP originate timestamp field.
ICMP field outbound hop count	ICMP_FIELD_OUTBOUND_HOP_COUNT	Value of the ICMP outbound hop count field.
ICMP field output link mtu	ICMP_FIELD_OUTPUT_LINK_MTU	Value of the ICMP output link MTU field.
ICMP field output link speed	ICMP_FIELD_OUTPUT_LINK_SPEED	Value of the ICMP output link speed field.
ICMP field pointer	ICMP_FIELD_POINTER	The offset in the related datagram where the situation occurred.
ICMP field preference level	ICMP_FIELD_PREFERENCE_LEVEL	Value of the ICMP preference level field.
ICMP field receive timestamp	ICMP_FIELD_RECEIVE_TIMESTAMP	Value of the ICMP receive timestamp field.
ICMP field return hop count	ICMP_FIELD_RETURN_HOP_COUNT	Value of the ICMP return hop count field.
ICMP field router addr	ICMP_FIELD_ROUTER_ADDRESS	Value of the ICMP router address field.
ICMP field sequence num	ICMP_FIELD_SEQUENCE_NUMBER	Value of the ICMP sequence number field.
ICMP field traceroute id	ICMP_FIELD_TRACEROUTE_ID	Value of the ICMP traceroute ID field.
ICMP field transmit timestamp	ICMP_FIELD_TRANSMIT_TIMESTAMP	Value of the ICMP transmit timestamp field.

**Table D.6 IPS Log Entry Fields (Continued)**

<b>Field</b>	<b>Syslog Export Field</b>	<b>Description</b>
ICMP ID	ICMP_ID	The ICMP identifier recorded by the engine when ICMP packets pass through the firewall. The ICMP identifier may be used by the echo sender to aid in matching the replies with the echo requests. For example, the identifier might be used like a port in TCP or UDP to identify a session. For more information on ICMP ID and the ICMP protocol, refer to <i>RFC 792</i> and <i>RFC 950</i> .
ICMP message length	ICMP_MESSAGE_LENGTH	Length of the ICMP message.
ICMP referenced destination IP addr	ICMP_REFERENCED_DESTINATION_IP_ADDR	Destination IP address of the datagram related to the ICMP message.
ICMP referenced destination port	ICMP_REFERENCED_DESTINATION_PORT	Destination port of the datagram related to the ICMP message.
ICMP referenced IP proto	ICMP_REFERENCED_IP_PROTO	IP Protocol field of the datagram related to the ICMP message.
ICMP referenced source IP addr	ICMP_REFERENCED_SOURCE_IP_ADDR	Source IP address of the datagram related to the ICMP message.
ICMP referenced source port	ICMP_REFERENCED_SOURCE_PORT	Source port of IP datagram related to the ICMP message.
ICMP Type	ICMP_TYPE	The Internet Control Message Protocol is an extension to the Internet Protocol (IP) that supports packets containing error, control and informational messages. ICMP messages are sent using the basic IP header. The first octet of the data portion of the datagram is an ICMP type field. For more information, refer to <i>RFC 792</i> and <i>RFC 950</i> .
Imf encoded word	IMF_ENCODED_WORD	Encoded word token related to this event.
Imf header field	IMF_HEADER_FIELD	Contents (possibly partial) of the mail header field related to this event.
Imf header field name	IMF_HEADER_FIELD_NAME	Name of the mail header field related to this event.
Imf header field position	IMF_HEADER_FIELD_POSITION	Number of characters processed in this header field when this event was generated.
Imf token	IMF_TOKEN	Syntactical token in the mail body related to this event.
Imf token length	IMF_TOKEN_LENGTH	Length of the syntactical token in the mail body related to this event.
Information message	INFO_MSG	A description of the log event that further explains the entry.

**Table D.6 IPS Log Entry Fields (Continued)**

<b>Field</b>	<b>Syslog Export Field</b>	<b>Description</b>
Inspection check parameter	MODPAR_VA	List of agent parameters and the defined values.
IP checksum	IP_CHECKSUM	Value of the IP header checksum.
IP datagram length	IP_DATAGRAM_LENGTH	Length of the IP datagram.
IP datagram new length	IP_DATAGRAM_NEW_LENGTH	The new suggested length for the IP datagram.
IP destination	IP_DEST	Destination IP address in the packet header. Included only for backwards compatibility for legacy IPS. For other cases, use Dst Addr.
IP frag conflict range	IP_FRAG_CONFLICT_RANGE AGMENT_OFFSET	Conflicting byte range in a fragment.
IP fragment offset	IP_FRAGMENT_OFFSET	Fragment offset in the IP header.
IP header length	IP_HEADER_LENGTH	Length of the IP header.
IP identification	IP_IDENTIFICATION	Identification field in the IP header.
IP offset	IP_OFFSET	Start IP offset from the beginning of the Ethernet frame.
IP option length	IP_OPTION_LENGTH	Length of the IP option that triggered the response.
IP option number	IP_OPTION_NUMBER	IP option number that triggered the response.
IP protocol	PROTOCOL	IP protocol of the traffic that generated the log event.
IP source	IP_SOURCE	Source IP address in the packet header. Included for backwards compatibility with legacy IPS. For other cases, use Src Addr.
IP total length	IP_TOTAL_LENGTH	Total length of the IP datagram.
IP version	IP_VERSION	Version field value in the IP header.
Length of message body	SIP_CONTENT_LENGTH	Length of the SIP message body.
Logical interface	IF_LOGICAL	Logical interface for a packet.
MAC destination	MAC_DEST	Destination MAC address in the packet header.
MAC source	MAC_SOURCE	Source MAC address in the packet header.
Module	SENDER_MODULE_ID	Sender module identification.
Module mem usage	MODULE_MEMUSAGE	Memory usage of each module.
Node configuration	NODE_CONFIGURATION	Current configuration of the node that sent the log entry.

**Table D.6 IPS Log Entry Fields (Continued)**

<b>Field</b>	<b>Syslog Export Field</b>	<b>Description</b>
Node dynup	NODE_DYNUP	Dynamic update package level of the node that sent the log entry.
Node version	NODE_VERSION	Node version of the node that sent the log entry.
Not final value	NOT_FINAL_VALUE	Entry is not final.
One LAN	ONE_LAN	The “View interface as one LAN” option was enabled on the logical interface through which the packet was received.
Orig config id	ORIG_CONFIG_ID	Configuration identifier related to the Situation in the referred event.
Orig sender module version	ORIG_SENDER_MODULE_VERSION	Module version in the referred event.
Orig sender os ver	ORIG_SENDER_OS_VER	The operating system version of the sender of the referred event.
Original Alert Type	ORIG_ALERT	Type of alert in the referred event.
Original correlation begin time	ORIG_TIME_FRAME_BEGIN	NTP stamp of the beginning of the time frame in the referred event.
Original correlation end time	ORIG_TIME_FRAME_END	NTP stamp of the end of the time frame in the referred event.
Original event count	ORIG_EVENT_COUNT	Number of events in the time frame of the referred event.
Original module	ORIG_SENDER_MODULE_ID	Sender module identification in the referred event.
Original severity	ORIG_ALERT_SEVERITY	Severity of the referred event.
Original situation	ORIG_SITUATION	Identifier of the situation that triggered the referred event.
Original time	ORIG_TIMESTAMP	Creation time of the referred event.
Packet analysis end	PACKET_ANALYSIS_END	Module could not continue analyzing packet or datagram after this event.
Packet not seen	PACKET_NOT_SEEN	Flag indicating that the related packet was not seen.
Physical interface	IF_PHYSICAL	Physical interface for a packet.
Protocol	PROTOCOL	Connection IP protocol.
Protocol Agent	SRVHELPER_ID	Protocol Agent numerical ID code.
Reception time	RECEPTION_TIME	Time when the entry was received by the Log Server.
Record ID	RECORD_ID	Identifier of the traffic recording.

**Table D.6 IPS Log Entry Fields (Continued)**

<b>Field</b>	<b>Syslog Export Field</b>	<b>Description</b>
Reference event ID	REF_EVENT	Reference to a related event.
Rule Tag	RULE_ID	Rule tag of the rule that triggered the log event.
Scan ICMP echo no reply cnt	SCAN_ICMP_ECHO_NO_RESPONSE_COUNTER	Number of distinct ICMP Echo Request (ping) destinations that did not reply to a request.
Scan ICMP echo request cnt	SCAN_ICMP_ECHO_REQUEST_COUNTER	Number of ICMP Echo Request destinations detected.
Scan ICMP echo targets	SCAN_ICMP_ECHO_TARGETS	List of the detected ICMP Echo Request destinations.
Scan ICMP mask no reply cnt	SCAN_ICMP_NETMASK_NO_RESPONSE_COUNTER	Number of ICMP Netmask Request destinations with no reply.
Scan ICMP mask request cnt	SCAN_ICMP_NETMASK_REQUEST_COUNTER	Number of distinct ICMP Netmask Request destinations detected.
Scan ICMP mask targets	SCAN_ICMP_NETMASK_TARGETS	List of the detected ICMP Netmask Request destinations.
Scan ICMP no reply cnt	SCAN_ICMP_NO_RESPONSE_COUNTER	Number of ICMP Echo, Timestamp, and Netmask Request destinations with no reply.
Scan ICMP request cnt	SCAN_ICMP_REQUEST_COUNTER	Number of ICMP Echo, Timestamp, and Netmask Request destinations.
Scan ICMP time no reply cnt	SCAN_ICMP_TIMESTAMP_NO_RESPONSE_COUNTER	Number of ICMP Timestamp Request destinations with no reply.
Scan ICMP time request cnt	SCAN_ICMP_TIMESTAMP_REQUEST_COUNTER	Number of distinct ICMP Timestamp Request destinations detected.
Scan ICMP time targets	SCAN_ICMP_TIMESTAMP_TARGETS	List of detected ICMP Timestamp Request destinations.
Scan start time	SCAN_START_TIME	Detected starting time of the port scanning activity that triggered the log event.
Scan TCP negative cnt	SCAN_TCP_NEGATIVE_COUNTER	Number of TCP destinations that replied with TCP Reset.
Scan TCP no ack cnt	SCAN_TCP_NO_ACK_COUNTER	Number of TCP destinations targeted for illegal TCP segments.
Scan TCP no ack targets	SCAN_TCP_NO_ACK_TARGETS	List of TCP destinations targeted for illegal TCP segments.
Scan TCP no reply cnt	SCAN_TCP_NO_RESPONSE_COUNTER	Number of TCP destinations with no reply to connection attempts.

**Table D.6 IPS Log Entry Fields (Continued)**

<b>Field</b>	<b>Syslog Export Field</b>	<b>Description</b>
Scan TCP normal cnt	SCAN_TCP_NORMAL_COUNTER	Number of TCP destinations with handshake and two-directional data transfer.
Scan TCP positive cnt	SCAN_TCP_POSITIVE_COUNTER	Number of TCP destinations with handshake but no data sent by client.
Scan TCP targets	SCAN_TCP_TARGETS	List of detected TCP port scan destinations in the traffic that triggered the log event.
Scan UDP negative cnt	SCAN_UDP_NEGATIVE_COUNTER	Number of destinations that replied with ICMP Port Unreachable.
Scan UDP positive cnt	SCAN_UDP_POSITIVE_COUNTER	Number of two-directional UDP conversations detected.
Scan UDP probe cnt	SCAN_UDP_PROBE_COUNTER	Number of destinations that did not reply using UDP.
Scan UDP target cnt	SCAN_UDP_TARGET_COUNTER	Total number of UDP destinations detected.
Scan UDP targets	SCAN_UDP_TARGETS	List of detected UDP destinations.
Sender	NODE_ID	IP address of the engine or server that sent the log entry.
Sender module version	SENDER_MODULE_VERSION	Version of the engine module that generated the event.
Sender type	SENDER_TYPE	The type of engine or server that sent the log entry.
Service	SERVICE	Special field for filtering logs using the defined services. Does not appear in the log entry table.
Severity	ALERT_SEVERITY	Severity of the situation related to the alert event.
SIP call ID	SIP_CALL_ID	SIP call ID.
SIP contact address	SIP_CONTACT	SIP contact address.
SIP header field contents	SIP_HEADER	SIP header field contents.
SIP header field name	SIP_HEADER_NAME	SIP header field name.
SIP request method	SIP_REQUEST_METHOD	Method of the SIP request.
SIP request URI	SIP_REQUEST_URI	URI of the SIP request.
SIP request version	SIP_REQUEST_VERSION	Version of the SIP request.

**Table D.6 IPS Log Entry Fields (Continued)**

<b>Field</b>	<b>Syslog Export Field</b>	<b>Description</b>
SIP response reason-phrase	SIP_RESPONSE_REASON_PHRASE	SIP response reason-phrase.
SIP response status code	SIP_RESPONSE_STATUS_CODE	Status code of the SIP response.
SIP VIA address	SIP_VIA	SIP VIA address.
Situation	SITUATION	The identifier of the situation that triggered the log event.
Situation Type	SIT_CATEGORY	The type of the situation that triggered the log event.
SMTP command	SMTP_COMMAND	Suspicious SMTP command sent by the client.
SMTP mail stats	SMTP_MAIL_STATS	Statistics on e-mail messages.
SMTP misplaced command	SMTP_MISPLACED_COMMAND	Command given in the wrong place in the command sequence.
SMTP recipient	SMTP_RECIPIENT	Recipient forward path in RCPT command parameter.
SMTP reply	SMTP_REPLY	Suspicious SMTP reply message sent by the server.
SMTP reverse path	SMTP_REVERSE_PATH	SMTP reverse path in MAIL FROM command parameter.
SMTP server action	SMTP_SERVER_ACTION	Suspicious server action after a suspicious client command.
SMTP server banner	SMTP_SERVER_BANNER	Banner sent by the SMTP server at the beginning of the connection.
SMTP transaction state	SMTP_TRANSACTION_STATE	Session state of the SMTP transaction.
Source file	SOURCE_FILE	Name of the source file.
Source file line	SOURCE_FILE_LINE)	Line number in the source file.
Source port	PORT_SOURCE	TCP or UDP source port in the packet header. Included for backwards compatibility with legacy IPS. For other cases, see Src Port.
Src Addr	SRC	Packet source IP address.
Src Port	SPOR	TCP or UDP source port in the packet header.
SSH calc client crypto bit ratio	SSH_CALC_CLIENT_CRYPTO_BIT_RATIO	Calculated SSH client crypto bit ratio.
SSH calc server crypto bit ratio	SSH_CALC_SERVER_CRYPTO_BIT_RATIO	Calculated SSH server crypto bit ratio.
SSH1 host key bits	SSH1_HOST_KEY_BITS	Bit length of the SSHv1 host key.

**Table D.6 IPS Log Entry Fields (Continued)**

Field	Syslog Export Field	Description
SSH1 server key bits	SSH1_SERVER_KEY_BITS	Bit length of the SSHv1 server key.
Syslog	SYSLOG_TYPE	Syslog is a system service used in some operating systems, e.g., UNIX- and software packages. For more information on syslog and syslog types, refer to <i>RFC 3164</i> .
Target IP	IP_TARGET	IPv4 address of the target host in a detected attack.
TCP connection start time	TCP_CONNECTION_START_TIME	Start time of the TCP connection.
TCP handshake seen	TCP_HANDSHAKE_SEEN	Initial handshake of the TCP connection detected.
TCP option kind	TCP_OPTION_KIND	Type of the TCP option.
TCP option length	TCP_OPTION_LENGTH	Length of the TCP option that caused the response.
To address	SIP_TO	SIP To address.
UDP datagram size	UDP_DATAGRAM_SIZE	Size of the UDP datagram.
Vulnerability References	VULNERABILITY_REFERENCES	References to known vulnerabilities in a vulnerability database. Generated from situation and original situation.
Whole session seen	WHOLE_SESSION_SEEN	True if no data of this session has been missed up to this point.

## Exportable IPS Recording Log Entry Fields

**Table D.7 IPS Recording Log Entry Fields**

Field	Syslog Export Field	Description
Component ID	COMP_ID	The identifier of the creator of the log entry.
Creation Time	TIMESTAMP	Log entry creation time.
Packet data	PACKET_DATA	Recorded packet data.
Record frame cached	RECORD_FRAME_CACHED	Marker showing that this frame was received before the recording was started. The frame included in the recording was taken from a memory cache.
Record ID	RECORD_ID ( <i>IPS and IPS recording only</i> )	Identifier of the traffic recording.
Sender	NODE_ID	IP address of the engine or server that sent the log entry.

# Exportable SSL VPN Log Entry Fields

Table D.8 SSL VPN Log Entry Fields

Field	Syslog Export Field	Description
Application	APPLICATION	The SSL VPN service that generated the log.
Application Detail	APPLICATION_DETAIL	The type of log sent by the SSL VPN. Possible values: SYSTEM, AUDIT, HTTP, DEBUG, BILLING, RADIUS, EVENT.
Creation Time	TIMESTAMP	Log entry creation time.
Information message	INFO_MSG	A description of the log event that further explains the entry.
Reception time	RECEPTION_TIME	Time when the entry was received by the Log Server.
Sender	NODE_ID	IP address of the engine or server that sent the log entry.
Username	USERNAME	Username of the user to which this log event is related.
Message Id	MESSAGE_ID	SSL VPN-internal identifier of the log entry.
Session Id	SESSION_ID	ID of the User Session.
Log Severity	LOG_SEVERITY	The severity assigned to the log entry by the SSL VPN-internal logging system. Possible values: Debug, Fatal, Info, Unknown, Warning.

## Facility Field Values

The following table lists the possible values for the Facility field in the log table.

Table D.9 Facility Field Values

Value
Accounting
Authentication
Blacklisting
Cluster Daemon
Cluster Protocol
Connection Tracking
Data Synchronization
DHCP Client
DHCP Relay
Invalid

**Table D.9 Facility Field Values (Continued)**

<b>Value</b>
IPsec
License
Load balancing filter
Log Server
Logging System
Management
Monitoring
NetLink Incoming HA
Network Address Translation
Packet Filter
Protocol Agent
Server Pool
SNMP Monitoring
State Synchronization
Syslog
System
Tester
Undefined
User Defined

# Type Field Values

---

The following table lists the possible values for the Type field in the log table.

**Table D.10** Type Field Values

<b>Value</b>
Critical Error
Debug high
Debug low
Debug mid
Diagnostic
Emergency - System Unusable
Error
Informational
Internal max
Max
Notification
System Alert
Undefined
Warning

## Action Field Values

The following table show the most common log occurrences for the Action field.

**Table D.11 Action Field Values**

Action	Description
Allow	A connection was allowed through the engine. This can be a new connection, a related connection (for example, an FTP data connection), a related packet (for example ICMP error messages related to an earlier TCP connection), or a new connection through an existing VPN tunnel.
Discard	A connection or packet was discarded by the engine.
Permit	A connection was allowed through according to the Inspection Rules on the engine.
Refuse	A connection was refused by the engine.
Terminate	A connection was terminated by the engine.
Terminate (failed)	An attempt to terminate a connection failed.
Terminate (passive)	A connection matched a rule with the passive Terminate action, and a log entry indicating that the connection would have been terminated was produced.
Terminate (reset)	A connection was terminated by the engine and TCP resets were sent to both communicating hosts.
Wait for Authentication	A connection was waiting for successful user authentication before it could continue.
Wait for Further Actions	A connection was waiting for some other action before it could continue.
Wait for RPC Reply	A connection was waiting for an RPC reply before it could continue.

## Event Field Values

The following table show the most common log occurrences for the Event field.

**Table D.12 Event Field Values**

Event	Description
Allowed a connection from blacklister	A connection from a blacklister was allowed.
Application protocol version is not supported	The application protocol version used in the traffic is not supported.
Application protocol version not recognized	The application protocol version used in the traffic was not recognized.
Authentication error	There was an error in the user authentication process.

**Table D.12 Event Field Values (Continued)**

<b>Event</b>	<b>Description</b>
Authentication failed	A user did not successfully authenticate.
Authentication Server does not respond	There is no response from the Authentication Server.
Authentication succeeded	A user successfully authenticated.
Automatic online transition	An engine automatically went online.
Automatic standby transition	An engine automatically went to standby.
Blacklister not allowed	The component that attempted to send a blacklist request is not on the list of Allowed Blacklisters.
Blacklisting connection closed	A connection from a blacklister was closed.
Blacklisting entries flushed	All entries were removed from the engine's blacklist.
Blacklisting entry deleted	An entry was removed from the engine's blacklist.
Blacklisting entry expired	A blacklisting entry reached the end of its Duration time.
Can't connect to log server	The engine is unable to connect to the Log Server.
Configuration changed	The engine's configuration changed.
Configuration information for this connection	The engine's configuration at the time the connection was logged.
Connection cannot be redirected to CIS due to absence of source NAT rule	Redirection to a Content Inspection Server failed because there was no NAT rule to redirect the connection.
Connection closed	A connection was closed.
Connection Discarded	A connection was discarded by the engine.
Connection Queued	A connection was queued according to the QoS rules.
Connection redirected to Content Inspection Server	A connection was redirected to an external Content Inspection Server.
Connection Refused	A connection was refused by the engine.
Connection Terminated	A connection was terminated by the engine.
Data connection cannot be redirected to CIS due to absence of source NAT rule	Redirection to a Content Inspection Server failed because there was no NAT rule to redirect the data connection.
Data connection redirected to content inspection server	A data connection was redirected to an external Content Inspection Server.
DHCP message received	A DHCP message was received.

**Table D.12 Event Field Values (Continued)**

<b>Event</b>	<b>Description</b>
DHCP Relay address not configured, reply discarded	A DHCP reply was discarded because no DHCP address is configured for the engine.
DHCP Relay address spoofed, request discarded	A DHCP request was discarded because the DHCP relay address was considered spoofed.
DHCP reply received	A DHCP reply was received.
DHCP reply sent	A DHCP reply was sent.
DHCP request forwarded	A DHCP request was forwarded.
DHCP request received	A DHCP request was received.
DHCP request sent	A DHCP request was sent.
Dropped AH packet	An IPsec AH packet was dropped.
Dropped ESP packet	An IPsec ESP packet was dropped.
Error in receiving a new configuration	There was an error when trying to transfer a new configuration to the engine.
Error with Content Inspection Server	There was an error when attempting to redirect a connection to an external Content Inspection Server.
Failed to allow a related connection to open	The engine failed to open a related connection for a connection that had already been allowed.
Force offline by test failure	The engine was forced offline as the result of an automated test failing.
Going locked offline by command	An administrator commanded the engine to go to the locked offline state.
Going locked online by command	An administrator commanded the engine to go to the locked online state.
Going offline by command	An administrator commanded the engine to go offline.
Going offline by test failure	The engine went offline as the result of an automated test failing.
Going online by command	An administrator commanded the engine to go online.
Going standby by command	An administrator commanded the engine to go to standby.
Hybrid authentication done	Hybrid authentication successfully completed.
Hybrid authentication failed	Hybrid authentication failed.
Incomplete connection closed	A connection for which the TCP handshake did not complete was closed.

**Table D.12 Event Field Values (Continued)**

<b>Event</b>	<b>Description</b>
Internal engine error	An internal error occurred on the engine.
Internal error	An internal error occurred.
Invalid license	The engine has an invalid license.
Invalid properties of custom Protocol Agent	Invalid options have been configured for a custom Protocol Agent.
IPsec authentication error	An error occurred in IPsec authentication.
IPsec client cfg download done	The configuration for an IPsec VPN Client has finished downloading.
IPsec client cfg download failed	An attempt to download the configuration for an IPsec VPN Client failed.
IPsec client cfg download from	The configuration for an IPsec VPN Client was downloaded by the client at the source address.
IPsec IKE error	There was an error in the IKE negotiation for an IPsec VPN.
LDAP Server does not respond	An LDAP Server is not responding.
License exceeded	A throughput based license was exceeded.
Log spool corrupted	The data in the engine's log spool partition has become corrupted.
Log spool is becoming full	The engine's log spool partition is becoming full.
New blacklisting entry	A new entry was added to the engine's blacklist.
New configuration successfully installed	A new configuration was installed on the engine.
New connection	A new connection was allowed through the engine.
New VPN connection	A new connection through an existing VPN tunnel was allowed.
No space left on device	The engine's hard drive is full.
No suitable NAT rule found	No NAT rule matched a connection.
No suitable NAT rule found for related connection	No NAT rule matched a related connection.
Node booted	An engine node booted up.
Node down	An engine node is down.
Node up	An engine node is up.
Oversized DHCP message discarded	An excessively large DHCP message was discarded.

**Table D.12 Event Field Values (Continued)**

<b>Event</b>	<b>Description</b>
Packet Discarded	A packet was discarded by the engine.
Packet too long	A packet was too long.
Packet too short	A packet was too short.
Receive ICMP echo	An ICMP echo (ping) was received.
Related Connection	A related connection was allowed through the engine. For example, an FTP data connection.
Related Packet	A related packet was allowed through the engine. For example, ICMP error messages related to an earlier TCP connection.
Requested NAT cannot be done	There was an error when applying NAT to the traffic.
Security Policy reload	New security policy is loaded on the engine.
Send ICMP echo	An ICMP echo (ping) was sent.
Sending DHCP reply failed	The engine failed to send a DHCP reply.
Sending DHCP request failed	The engine failed to send a DHCP request.
Sending sync messages	The engine is sending synchronization messages.
Server pool member went offline	A Server Pool member went offline.
Server pool member went online	A Server Pool member went online.
SSL Handshake failed	An SSL handshake failed.
Starting hybrid authentication	Hybrid authentication started.
Starting IKE initiator negotiation	IKE initiator negotiation started.
Starting IKE responder negotiation	IKE responder negotiation started.
State sync communication failure	State synchronization communication between cluster nodes failed.
State sync configuration changed	The configuration of the synchronization communication between cluster nodes changed.
Unknown DHCP Relay error	An unknown error occurred in DHCP relay.
Unrecognized protocol	A protocol in the logged traffic was not recognized.
Went locked offline	The engine went to the locked offline state.
Went locked online	The engine went to the locked online state.
Went offline	The engine went offline.
Went online	The engine went online.

**Table D.12 Event Field Values (Continued)**

Event	Description
Went standby	The engine went to standby.

A successful engine login causes an event that is displayed in the Logs view with the following type of message in the Info Message field: *date time login[id]:USERNAME LOGIN on 'device'*. A failed login causes an info message of the following type: *date time login[id]:FAILED LOGIN (#) on 'device' FOR 'UNKNOWN'*.

## IPsec VPN Log Messages

The tables in this section list the most common IPsec VPN log messages (Facility=IPsec). Some messages can only be seen when the VPN diagnostics are enabled during the VPN negotiations. The messages listed appear in the Information Message fields of logs as information or error messages. The Situation field in some of the logs contains similar messages.

- [VPN Notifications](#) (page 177)
- [VPN Errors](#) (page 179)
- [VPN Error Codes](#) (page 181)

## VPN Notifications

The table below lists messages that are seen in the logs as part of normal IPsec VPN operation.

**Table D.13 Common IPsec VPN Messages in Normal Operation**

Information Message	Description
SA traffic selectors local: [...]	This message is visible only when IPsec diagnostics are enabled. The first message generated when new VPN negotiations are triggered. Negotiation of a new VPN tunnel follows.
IKE SA proposal [...]	This message is visible only when IPsec diagnostics are enabled. Shows the proposal that the initiator in the negotiations sent to the responder (displayed in both roles).
Starting IKE main mode initiator negotiation Starting IKE main mode responder negotiation	The beginning of IKE negotiations (in main mode). Which message is displayed depends on whether the gateway is the initiator or the responder in the negotiation. Repeated negotiations for the same connection are normal in a Multi-Link environment.
IKE Phase-1 initiator done [...] IKE Phase-1 responder done [...]	IKE Phase-1 negotiations were successfully completed, Phase-2 negotiations will begin. Which message is displayed depends on whether the gateway is the initiator or the responder in the negotiation.

**Table D.13 Common IPsec VPN Messages in Normal Operation (Continued)**

Information Message	Description
IKE Phase-2 initiator done [...] IKE Phase-2 responder done [...] [...]	IKE Phase-2 negotiations were successfully completed. The VPN tunnel is now established and ESP or AH message(s) should appear shortly.  Which message is displayed depends on whether the gateway is the initiator or the responder in the negotiation.
Starting Hybrid Authentication	Hybrid authentication is started for a StoneGate IPsec VPN client user.
Hybrid Authentication Done	Hybrid authentication succeeded for a StoneGate IPsec VPN client user.
IKE SA import succeeded IPsec SA import succeeded	This message is visible only when IPsec diagnostics are enabled. Synchronization of Phase 1 (IKE) and Phase 2 (IPsec) information between clustered firewall engines was successful.
ESP [...] AH [...]	Encrypted traffic going through the VPN tunnel. When you enable IPsec diagnostics you may see more of these messages.
Unknown IKE cookie	This message is visible only when IPsec diagnostics are enabled. The other gateway identified an SA that does not exist on this node. If this is a cluster, this message is normal when the SA has been negotiated with a different node and the correct SA is then queried from the other nodes, allowing the connection to continue.  This message can also appear if the SA has been deleted, for example, because of a timeout or dead peer detection (DPD).
Sending delete notification [...] Delete notification received [...] [...]	This message is visible only when IPsec diagnostics are enabled. Messages between the gateways forming the tunnel informing the other party that the gateway has removed the settings indicated in the message. As a result, the other gateway also clears the settings, allowing for renegotiations if the tunnel is still needed.
Sending IKE SA delete sync Receiving IKE SA expire/delete sync	This message is visible only when IPsec diagnostics are enabled. Synchronization of SA deletion information between clustered firewall engines.
Initial contact notification received	The gateway at the other end of the tunnel has sent an Initial-Contact message (indicating that it has no knowledge of previous negotiations). If there are old SAs with the gateway, they are deleted at this point (recently negotiated SAs are not, as may be indicated by a further log message). If SAs exist, the notification may indicate that the other end has been cleared, for example, in a reboot.

## VPN Errors

The table below lists common errors that indicate problems in an IPsec VPN tunnel. The log messages inform you about the stage of negotiations and then give the actual error message, for example, “IKE Phase-2 error: No proposal chosen”. The table lists only the actual message part without additional variable details such as IP addresses or identifiers.

**Table D.14 Common IPsec VPN Errors**

Error Message	Description
Access group mismatch	The connecting VPN client is not authorized.
Authentication failed	One of the parties rejected the authentication credentials or something went wrong during the authentication process. If the problem is not apparent in the available logs, activate diagnostics to generate more verbose logs that give you more information about the next negotiations.
Authentication method mismatch	The authentication method used by the other gateway is not allowed in the configuration of this gateway. Check the settings in the VPN Profile that is selected for this VPN.
Can not get policy [...] No matching connection	May indicate that the gateway has no valid VPN certificate.
Can not get QM policy [...]	Indicates that there is a mismatch in granularity settings between the negotiating gateways. In StoneGate, granularity is controlled with the Security Association Granularity setting on the IPsec Settings tab of the VPN Profile.
Could not allocate inbound SPI	Indications that the gateway has run out of memory. The reasons for this may include inappropriate configuration settings (such as using the “SA per host” setting with a very large number of hosts) in addition to other considerations (such as hardware specifications).
Could not create outbound IPsec rule	
Could not register outbound SPI	
Old outbound SPI entry not found	
Out of memory	
SA install failed	
Session attaching failed	
Transform creation failed	
Dead peer detection failed IKE peer was found dead [...]	Dead peer detection checks the other gateway periodically when the VPN is established. If no response is received, the VPN tunnel is closed. Indicates that the other gateway is down, unreachable, or considers the VPN tunnel already closed.
Encapsulation mode mismatch	Encapsulation modes (AH and/or ESP) did not match between gateways.

**Table D.14 Common IPsec VPN Errors (Continued)**

Error Message	Description
IKE error notify received: [...]	This message is visible only when IPsec diagnostics are enabled. The other gateway has sent the error notification that is shown in this message.
IKE negotiation rate-limit reached, discard connection	This message is visible only when IPsec diagnostics are enabled. There is an excessive number of new VPN connection attempts within a short period of time. This mechanism is meant to protect the firewall from certain types of denial-of-service attacks.
Invalid argument	Generic error. Check the other log messages for more useful information. If the problem is not apparent in the available logs, activate diagnostics to generate more verbose logs that give you more information about the next negotiations.
Invalid syntax	
IPsec SA proposal not accepted	This message is visible only when IPsec diagnostics are enabled. The VPN gateway at the other end of the tunnel sent a proposal that the StoneGate gateway could not accept. This message includes information about the rejected proposal and a further log message should contain information on StoneGate's local proposal.
NAT-T is not allowed for this peer	This message is visible only when IPsec diagnostics are enabled. NAT-T was requested by the other gateway but it is not allowed in the configuration of the gateway that sends this message.
No proposal chosen	IKE negotiations failed. If the problem is not apparent in the available logs, activate diagnostics to generate more verbose logs that give you more information about the next negotiations.
Payload malformed [...]	Most likely due to a mismatch in preshared keys between the initiator and the responder. May also be due to corruption of packets in transit.
Peer IP address mismatch	The IP address of the other gateway uses is not configured as a VPN gateway end-point on this gateway.
Proposal did not match policy	There is a mismatch in the configurations of the two negotiating parties.
Remote address not allowed	A VPN client is trying to use an IP address that is out of the allowed address range. Make sure all valid IP addresses are actually included in the range of allowed addresses in the Internal VPN Gateway properties and check the DHCP server configuration.
Remote ID mismatch  Remote identity [...] used in IKE negotiation doesn't match to policy [...]	The IKE Phase 1 ID defined for the external security gateway in StoneGate is different from the ID with which the gateway actually identified itself. The ID and its type are set for each tunnel End-Point in the properties of the external Gateway. Note that if an IP address is used as identity, the IP address used as the identity may be different from the IP address used for communications.
SA unusable	Usually means that an SA is being deleted when some new traffic arrives to use the tunnel.

**Table D.14 Common IPsec VPN Errors (Continued)**

<b>Error Message</b>	<b>Description</b>
Sending error notify: [...]	This message is visible only when IPsec diagnostics are enabled. Negotiations have failed and StoneGate is sending the error notification that is shown in this message to the other gateway.
SPD doesn't allow connection [...]	Most likely indicates that the Site definitions do not match the IP addresses used. Check the addresses included under the Sites for both Gateways, and also that the translated addresses are included under the Site, if NAT is used for communications inside the VPN.
Timed out	Indicates connection problems or that the other end has deleted the SA that StoneGate is using in the negotiation. Check the logs at the other end to see if the connection makes it through.
Traffic selector mismatch	There is a mismatch in the configurations of the two negotiating parties. You must define a matching pair for all settings; double-check all settings at both ends.
Tunnel policy mismatch [...]	This message is visible only when IPsec diagnostics are enabled. Usually indicates IKE negotiations failed because of a mismatch in the configurations of the two negotiating parties.
Tunnel selection failed	An Access rule matched this connection, but the traffic could not be sent across the VPN. Most likely, this is due to the (possibly NATed) source or destination IP address not being included in the local or remote gateway's Site as required. This message also appears if a connection that is not intended for the VPN matches the VPN rule (note that inbound cleartext traffic can be allowed from the same addresses as tunneled traffic with the Apply action in the VPN rule).
Tunnel type mismatch [...]	This message is visible only when IPsec diagnostics are enabled. Only gateway-to-gateway VPN or client-to-gateway VPN is configured, but the connecting device is of the other type. For example, a VPN client tried to connect, but VPN client access is not configured (correctly) on the gateway.

## VPN Error Codes

Under some conditions, multiple IPsec VPN errors may be detected simultaneously and combined in a single log message. The most significant error is shown as text, and the other detected errors are indicated using a combined (with bitwise OR) hexadecimal error code.

**Example IKE Phase-1 Initiator error: Proposal did not match policy (100002).**

Here, the hexadecimal codes

00100000 for "Proposal did not match policy" and  
 00000002 for "Peer IP address mismatch") produces the code  
 00100002 = 100002.

The table below lists codes that are valid for engine software versions 5.0 and above.

**Table D.15 Hexadecimal Error Codes in VPN Log Messages**

Hex Code	Error Message
00000020	Access group mismatch
00008000	Authentication method mismatch
00020000	Encapsulation mode mismatch
00000002	Peer IP address mismatch
00100000	Proposal did not match policy
00400000	Remote address not allowed
00000040	Traffic selector mismatch (local)
00000080	Traffic selector mismatch (remote)
00200000	Tunnel type mismatch
00000200	Remote ID mismatch
00000100 00000004 00000001	Internal configuration-related problems. See the other messages to troubleshoot.

## Audit Entry Types

The following table explains the audit entry types.

**Table D.16 Audit Entry Types**

Type	Definition
audit.info	Internal messages of the audit system.
audit.start	Start of an audit.
audit.stop	End of an audit.
stonegate.admin.changelp.mgtserver	Audited when management server IP address is changed.
stonegate.admin.changeMgtIp.logserver	Audited when log server management IP address is changed.
stonegate.admin.comment.change	Audited when a comment is changed.
stonegate.admin.create	Creation of an administrator.
stonegate.admin.delete	Deletion of an administrator.
stonegate.admin.login	Audited when the administrator logs in to the management server.

**Table D.16 Audit Entry Types (Continued)**

<b>Type</b>	<b>Definition</b>
stonegate.admin.logout	Audited when the administrator logs out from the management server.
stonegate.admin.name.change	Change of administrator name.
stonegate.admin.password.change	Change of password for an administrator.
stonegate.admin.permission.change	Change of permissions for an administrator.
stonegate.admin.session	Audits administrator sessions.
stonegate.alert	Audited when management system sends an alert.
stonegate.alert.policy.upload	Uploading a policy to an alert server - success or failure.
stonegate.audit.archive.create	Audited when audit data archive is created.
stonegate.audit.archive.delete	Audited when audit data archive is deleted.
stonegate.audit.archive.restore	Audited when audit data archive is restored.
stonegate.backup.create	Audited when a backup is created in the origin server.
stonegate.backup.delete	Audited when a backup is deleted in the origin server.
stonegate.backup.restore	Audited when a backup is restored in the origin server.
stonegate.database.migrate	Audited when the server database is migrated.
stonegate.database.password.change	Audited when database password is changed.
stonegate.directarchive.start	Audited when the direct archive option is set to ON.
stonegate.directarchive.stop	Audited when the direct archive option is set to OFF.
stonegate.export.start	Audited when an export operation is started.
stonegate.firewall.connections.terminate	Audited when a connection is terminated.
stonegate.firewall.diagnostic	Diagnostic mode selected for a firewall.
stonegate.firewall.disable.userdatabase	Audited when user database is disabled.
stonegate.firewall.enable.userdatabase	Audited when user database is enabled.
stonegate.firewall.initial.contact	Firewall performed initial contact to management server.
stonegate.firewall.initial.generate	Initial configuration generated for a firewall.
stonegate.firewall.monitor.off	A firewall monitoring change by an administrator to deactivated.
stonegate.firewall.monitor.on	A firewall monitoring change by an administrator to activated.
stonegate.firewall.policy.upload	Uploading a policy to a single firewall - success or failure.

**Table D.16 Audit Entry Types (Continued)**

<b>Type</b>	<b>Definition</b>
stonegate.firewall.reboot	A firewall reboot by an administrator through the management system.
stonegate.firewall.reset.database	Audited when the user database is reset.
stonegate.firewall.state.lockoffline	A firewall state change by an administrator to locked offline.
stonegate.firewall.state.lockonline	A firewall state change by an administrator to locked online.
stonegate.firewall.state.offline	A firewall state change by an administrator to offline.
stonegate.firewall.state.online	A firewall state change by an administrator to online.
stonegate.firewall.state.standby	A firewall state change by an administrator to standby.
stonegate.firewall.time.adjust	Firewall node time adjustment.
stonegate.firewall.upgrade.end	Firewall node upgrade end through management system.
stonegate.firewall.upgrade.start	Firewall node upgrade start through management system.
stonegate.import.start	Audited when an import operation is started.
stonegate.ips.analyzer.diagnostic	Diagnostic mode selected for an analyzer.
stonegate.ips.analyzer.monitor.off	Monitoring mode offline for a sensor.
stonegate.ips.analyzer.monitor.on	Monitoring mode online for a sensor.
stonegate.ips.analyzer.policy.upload	Uploading a policy to an analyzer - single analyzer cluster success or failure.
stonegate.ips.analyzer.reboot	Analyzer reboot through the management system.
stonegate.ips.analyzer.state.lockoffline	Analyzer state changed to locked offline.
stonegate.ips.analyzer.state.lockonline	Analyzer state changed to locked online.
stonegate.ips.analyzer.state.offline	Analyzer state changed to offline.
stonegate.ips.analyzer.state.online	Analyzer state changed to online.
stonegate.ips.analyzer.state.standby	Sensor state changed to standby.
stonegate.ips.analyzer.time.adjust	Analyzer node time adjusted.
stonegate.ips.analyzer.upgrade.end	Analyzer node upgrade through management system ends.
stonegate.ips.analyzer.upgrade.start	Analyzer node upgrade through management system begins.
stonegate.ips.sensor.diagnostic	Diagnostic mode selected for a sensor.

**Table D.16 Audit Entry Types (Continued)**

Type	Definition
stonegate.ips.sensor.monitor.off	Monitoring mode offline for a sensor.
stonegate.ips.sensor.monitor.on	Monitoring mode online for a sensor.
stonegate.ips.sensor.policy.upload	Uploading a policy to a sensor - single sensor success or failure.
stonegate.ips.sensor.reboot	Sensor rebooted through the management system.
stonegate.ips.sensor.state.lockoffline	Sensor state changed to locked offline.
stonegate.ips.sensor.state.lockonline	Sensor state changed to locked online.
stonegate.ips.sensor.state.offline	Sensor state changed to offline.
stonegate.ips.sensor.state.online	Sensor state change by an administrator to online.
stonegate.ips.sensor.state.standby	Sensor state changed to standby.
stonegate.ips.sensor.time.adjust	Sensor node time adjusted.
stonegate.ips.sensor.upgrade.end	Sensor node upgrade through management system ends.
stonegate.ips.sensor.upgrade.start	Sensor node upgrade through management system begins.
stonegate.license.activate	Audited when a license file or a license component is activated.
stonegate.license.delete	Audited when a license component is deleted.
stonegate.license.import	Audited when a license file is imported.
stonegate.license.inactivate	Audited when a license is deactivated.
stonegate.logdatamanager.abort	Audited when a scheduled task is aborted in the log server.
stonegate.logdatamanager.complete	Audited when a scheduled task is completed in the log server.
stonegate.logdatamanager.create	Audited when a scheduled task is created in the log server.
stonegate.logdatamanager.delete	Audited when a scheduled task is deleted in the log server.
stonegate.logdatamanager.modify	Audited when a scheduled task is modified in the log server.
stonegate.logdatamanager.start	Audited when the user manually starts a task.
stonegate.logpruningfilter.apply	Audited when a pruning filter is applied to the log server.
stonegate.logpruningfilter.delete	Audited when a pruning filter is deleted from the log server.

**Table D.16 Audit Entry Types (Continued)**

<b>Type</b>	<b>Definition</b>
stonegate.logpruningfilter.refresh	Audited when, following to a log server re-logging to the management, all the pruning filters are retrieved at the management and re-applied.
stonegate.logreception.start	Log reception process begins.
stonegate.logreception.stop	Log reception process ends.
stonegate.logserver.certify	Audited when the log server is certified.
stonegate.mgtserver.certify	Audited when the management server is certified.
stonegate.object.delete	Audited when an object is deleted.
stonegate.object.insert	Audited when a new object is added.
stonegate.object.update	Audited when an object is updated.
stonegate.policy.display	Generate a policy for display.
stonegate.policy.upload.end	Uploading a policy ends.
stonegate.policy.upload.start	Uploading a policy starts.
stonegate.server.diskfull	Audited when the log server disk gets full.
stonegate.server.start	Audited when the log server is started.
stonegate.server.stop	Audited when the log server is stopped.
stonegate.vpn.certificate.download	Audited when client downloaded a VPN certificate.
stonegate.vpn.certificate.request	Audited when a VPN certificate is requested.
stonegate.vpn.certificate.sign	Audited when a VPN certificate is signed.
stonegate.vpn.gateway.remove	Audited when a VPN gateway is removed.
stonegate.vpn.site.remove	Audited when a VPN site is removed.
stonegate.vpn.validity.check	Audited when the VPN validity is checked.

# Syslog Entries

---

The following table presents the categories for messages that appear in log entries sent to an external syslog server.

**Table D.17 Syslog Entries**

Value
Clock daemon for BSD systems
Clock daemon for System V systems
File transfer protocol
Kernel messages
Line printer subsystem
Mail system
Messages generated internally by syslogd
Network news subsystem
Network time protocol
Random user-level messages
Security/authorization messages
Security/authorization messages (private)
System daemons
UUCP subsystem

## Log Fields Controlled by the Additional Payload Option

---

The following table presents the log fields that may be logged when the Additional Payload option is selected in an Inspection rule's Logging options.

**Table D.18 Additional Payload Log Fields**

Value
DNS qname
FTP command
FTP reply
FTP server banner
HTTP header
HTTP header name

**Table D.18 Additional Payload Log Fields (Continued)**

Value
HTTP request URI
HTTP request method
HTTP request version
ICMP field datagram reference
Imf encoded word
Imf header field
Imf token
SMTP command
SMTP misplaced command
SMTP recipient
SMTP reply
SMTP reverse path
SMTP server banner

## Connection States

The following states are used both in the **State** column in the Connections view and (in part) in the Logs view in conjunction with info messages or logs on the closing of connections. They reflect the standard states regarding the initiation and termination of TCP connections as seen by the firewall in the transmissions. The table below lists the possible states.

**Table D.19 Connection States**

State	Description
CP established	StoneGate cluster protocol packet is recognized.
ICMP echo	Ping reply is expected.
ICMP reply wait	Other ICMP request/reply types.
Invalid	The communication has violated the protocol.
IPsec established	IPsec tunnel packet is recognized.
New	New connection is being opened.
Related	New connection related to an existing one is expected soon.
Remove	Connection cannot be physically removed yet.

**Table D.19 Connection States (Continued)**

State	Description
Remove soon	Expecting to still see some packets (multiple reset packet), so delaying the removal for a few seconds. Eliminates unnecessary packet filtering and possible logging of dropped packets.
TCP close wait	One end of the connection waits for the FIN packet (passive close).
TCP close wait ack	Waiting for ACK for the FIN before going to close wait status (passive close).
TCP closing	Closing packet (FIN) sent by one end of the connection (simultaneous).
TCP closing ack	Waiting for ACK for the FIN before going to closing status (active close).
TCP established	Normal status of TCP connections for data transfer.
TCP fin wait 1	One end of the connection waits for sending the FIN packet (active close).
TCP fin wait 2	One end of the connection waits for receiving ACK packet.
TCP last ack	One end of the connection sent a FIN packet (passive close).
TCP last ack wait	Waiting for the FIN packet to be acknowledged.
TCP syn ack seen	Second phase of the TCP three-way handshake, the server has replied to client sent SYN with SYN+ACK, next status will be established.
TCP syn fin seen	T/TCP (Transactional TCP) connection, RFC 1644.
TCP syn return	Received simultaneous SYN from the other end (simultaneous open).
TCP syn seen	Very first packet sent by one end of the connection.
TCP time wait	One end of the connection acknowledged closing packet (FIN).
TCP time wait ack	Waiting for ACK for the FIN status before going to time wait status (active close).
UDP established	UDP connection is recognized.
Unknown established	Connection from other transport level protocol.



## APPENDIX E

# SCHEMA UPDATES FOR EXTERNAL LDAP SERVERS

This section lists the StoneGate-specific LDAP classes and attributes that you add to the schema of external LDAP servers.

The StoneGate specific attribute and class names start with “sg”. The classes are listed in the table below.

**Table E.1 StoneGate Specific LDAP Classes**

Class	Description
sggroup	StoneGate user group
sguser	StoneGate user account

The StoneGate specific attributes are listed in the table below.

**Table E.2 StoneGate Specific LDAP Attributes**

Attribute	Related Classes	Description
sgactivation	sguser	Activation date for the user account.
sgauth	sggroup, sguser	Authentication service for the user or group.
sgdelay	sggroup, sguser	Number of days the user account is valid after the activation.
sgexpiration	sguser	Last day when the user account is valid and the user can log in.
sggroupstype	sggroup	Indicates the type of the group: a subtree or discrete group.
sgmember	sggroup	The Distinguished Name (DN) for the user member of this group.

**Table E.2 StoneGate Specific LDAP Attributes (Continued)**

Attribute	Related Classes	Description
sgpassword	sguser	MD5 message digest hash of the user password.
sgpresharedkey	sguser	IPsec PreSharedKey for the user account.
sgsubjectaltnames	sguser	IPsec certificate SubjectAltNames for the user account.
sgvirtualip	sggroup, sguser	Virtual IP allocation allowed for the user.

Example schema updates are provided in the Management Servers' *<installation directory>/samples/LDAPSamples/LDAP/* directory:

- *SG\_AD.ldif* is an example schema update for Windows Server 2003 and 2008 Active Directory. For additional considerations and instructions on extending the schema, consult Microsoft's Documentation:
  - For Windows 2003, see <http://technet.microsoft.com/en-us/library/cc759633%28WS.10%29.aspx>.
  - For Windows 2008, see <http://technet.microsoft.com/en-us/library/cc771796%28WS.10%29.aspx>.
- *SG-v3.schema* is an example schema update in the LDAPv3 format (RFC 2252) used by OpenLDAP v.2.0.x and later, for example.
- *SG-schema.conf* is an example schema update in slapd.conf format, used by Netscape Directory server and OpenLDAP version 1.2.11, for example.

In addition to updating the directory schema, there may be some server-specific requirements. For the Netscape and the OpenLDAP version 1.2.11 servers, you must configure the following lines to the LDAP server's *slapd.conf* configuration file after stopping the LDAP service:

#### Illustration E.1 Additional Configuration for OpenLDAP v1.2.11 and Netscape Server

```
include /etc/openldap/slapd.at.conf
include /etc/openldap/slapd.oc.conf
include /etc/openldap/sg-schema.conf
schemacheck on
```

For the OpenLDAP server versions 2.0 and later, you must configure the following lines to the LDAP server's *slapd.conf* configuration file after stopping the LDAP service:

#### Illustration E.2 Additional Configuration for OpenLDAP version 2.0 or later

```
include /etc/openldap/schema/core.schema
include /etc/openldap/schema/cosine.schema
include /etc/openldap/schema/inetorgperson.schema
include /etc/openldap/schema/sg-v3.schema
```

# GLOSSARY

## A

### **Access Control List**

A list of Elements that can be used to define the Elements that an administrators with restricted permissions can access. See also [Administrator Role](#) and [Granted Element](#).

### **Action**

What the firewall engine should do with a packet that matches the criteria for a particular rule in the security policy.

### **Action Option**

Additional action-specific selections that affect how the traffic is handled set in the Action cell in rules.

### **Active Management Server**

See [Primary Management Server](#) (page 211).

### **Address Range**

A [Network Element](#) that defines a range of IP addresses. Use to avoid having to repeatedly type in the same IP addresses when defining address ranges that do not correspond to whole networks.

### **Address Resolution Protocol (ARP)**

An Internet standard (RFC 826) protocol used to associate IP addresses with the media hardware address of a network interface card on a local area network (LAN).

### **Administrator**

An [Element](#) that defines the details of a single person that is allowed to log on to the SMC using the Management Client. If used as a general term, Web Portal Users are also considered as administrators.

### **Administrator Role**

An Element that defines which actions an [Administrator](#) with restricted permissions is allowed to take. See also [Granted Element](#) and [Permission Level](#).

### **Aggressive Mode**

The authentication of two IPsec end-points with only three messages, as opposed to Main Mode's six. Aggressive mode also does not provide PFS support, and SA negotiation is limited. See [Main Mode](#) (page 208). See also [Security Association \(SA\)](#) (page 214).

### **AH (Authentication Header)**

See [Authentication Header \(AH\)](#) (page 195).

## Alert Chain

A list of rules defining which [Alert Channels](#) are used, and in which order, when an alert entry is directed to the Alert Chain from an [Alert Policy](#) to be escalated out from the Management Center. See also [Alert Escalation](#).

## Alert Channel

A method of sending alerts out from the [Log Server](#). You can send alerts via SMTP (e-mail), SNMP, SMS text messages, or some other action you define in a custom script. Alert Channels are defined in the Log Server's properties, after which they can be used in [Alert Chains](#).

## Alert Element

An [Element](#) that gives the name and description to an [Alert Event](#). The Alert element can be used as a matching criteria in the rules of an [Alert Policy](#).

## Alert Entry

A log message with an alert status that has been raised based on some [Situation](#) (which you can see in the [Logs View](#)). Alert entries trigger [Alert Escalation](#).

## Alert Escalation

Sending alerts out from the Management Center to administrators through [Alert Channels](#) (such as e-mail) according to a predefined [Alert Chain](#) until the original [Alert Entry](#) is acknowledged by some administrator in the [Logs View](#).

## Alert Event

A pattern in traffic or a problem in the system's operation that matches to some [Situation](#) used in a policy or internally in the system, and thus triggers an [Alert Entry](#).

## Alert Policy

A list of rules defining if an [Alert Entry](#) is escalated and which [Alert Chain](#) is used for escalating which type of alert entries. See also [Alert Escalation](#).

## Alert Server

A StoneGate Management Center component that handles receiving and handling of Alerts. The Alert Server cannot be installed separately, it is integrated in the [Log Server](#) installation.

## Alias

An [Element](#) that can be used to represent other network elements in configurations. It differs from a group element in that it does not represent all the elements at once: the value it takes in a configuration can be different on each engine where it is used.

## Allow Action

An [Action](#) parameter that allows a connection matching that rule to pass through the firewall to its destination.

## Analyzer

- 1) A device in the StoneGate IPS system that analyzes the log information from [Sensors](#) according to its policy to find patterns, so that separate log entries can be combined together.
- 2) The [Network Element](#) that represents an Analyzer device in the Management Center.

## **Antispoofing**

Technique used to protect against malicious packages whose IP header information has been altered. See also [IP Spoofing](#) (page 206).

## **Application**

A category of [Tags](#) for [Situations](#). Meant for grouping Situations that detect known vulnerabilities in a particular software application.

## **Application Layer Gateway; Application Level Firewall**

A firewall system, or gateway, in which packets are examined based on the application protocol being used (e.g., telnet, FTP, SMTP). Proxies for each application-level service are installed on the gateway, and are often configured to relay a conversation between two systems. That is, a packet's destination is the gateway, which then establishes a separate connection to the other system to complete the connection.

## **Apply VPN Action**

A Firewall [Action](#) parameter that directs traffic from protected local networks into the [Virtual Private Network \(VPN\)](#) tunnel and allows traffic that arrives through a VPN, but does not match non-VPN traffic from outside networks into the protected networks. See also [Enforce VPN Action](#) (page 201).

## **ARP (Address Resolution Protocol)**

See [Address Resolution Protocol \(ARP\)](#) (page 193).

## **Asymmetric Encryption**

A cryptographic technology that uses a pair of keys. The message is encrypted with the public half of a pair and can then be decrypted only with the matching private half of the key pair. Public key technology can be used to create digital signatures and deal with key management issues. Also referred to as public key encryption. See also [Symmetric Encryption](#) (page 217) and [Public-key Cryptography](#) (page 212).

## **Auditing**

A Management Center feature that logs administrators' actions and allows administrators with unrestricted permissions to view and manage these logs to keep track of system changes.

## **Authentication**

The process of proving that someone or something is who or what they claim to be. For example, typing a simple username-password combination is a form of authentication.

## **Authentication Header (AH)**

A security protocol supported by the IPsec protocol to enhance traffic security. It enables the authentication and integrity of data against packet corruption or tampering. AH protocol can use SHA-1 or MD5 to generate a hash signature based on a secret component from the SA, the packet payload and some parts of the packet header. See also [Security Association \(SA\)](#) (page 214).

## **Authentication Token/Authenticator**

A portable device for authenticating a user. Authentication tokens typically operate by challenge/response, time-based code sequences, or other techniques. One of the most commonly used tokens is the RSA SecurID card.

## B

### **Authorization**

The process of giving someone/something permission to do or have something. Usually related to authentication; once a user has authenticated (proved who they are), they are authorized (given permission) to perform certain actions.

### **Balancing Mode**

A StoneGate cluster mode that attempts to divide the traffic as equally as possible between the online engines participating in the cluster. Confer to [Standby Mode](#) (page 217).

### **Bandwidth Management**

The process of determining and enforcing bandwidth limits and guarantees for different types of traffic either together with [Traffic Prioritization](#) or on its own. Also see [QoS Class](#) (page 212) and [QoS Policy](#) (page 212).

### **Blacklisting**

- 1) The process of blocking unwanted network traffic either manually or automatically.
- 2) Persistently blocking access to certain URLs manually.

### **Bookmark**

A stored link to a view or layout in the [Management Client](#).

### **Bookmark Folder**

A folder in the toolbar of the [Management Client](#) for storing and sharing [Bookmarks](#).

### **Boot Recovery**

A StoneGate setting that brings the engines automatically back online after boot-up.

### **Border Routing**

Routing of connections between different autonomous systems.

### **BrightCloud**

A [Web Filtering](#) categorization service that provides categories for malicious sites as well as several categories for different types of non-malicious content that may be considered objectionable.

### **Buffer Overflow**

When a program's data in the memory of a computer exceeds the space reserved for it (the buffer), data may in some circumstances be written on other parts of the memory area. Attackers may use buffer overflows to execute harmful program code on a remote system.

### **Bugtraq**

A mailing list for discussing network security related issues, such as vulnerabilities.

### **Bulk Encryption Algorithm**

Describes symmetric encryption algorithms which operate on fixed-size blocks of plaintext and generates a block of ciphertext for each.

**CA**

See [Certificate Authority \(CA\)](#) (page 197).

**CAN**

A candidate for a [CVE](#) entry.

**Capture Interface**

A [Sensor](#) interface that can listen to traffic passing in the network, but which is not used for routing traffic through the Sensor. See also [Inline Interface](#).

**Category**

A way of organizing elements and policies to display a specific subset at a time when configuring a large StoneGate system in the Management Client to make it easier to find the relevant elements when configuring the system. For example, a Managed Service Provider (MSP) who manages networks of several different customers can add a customer-specific category to each element and policy to be able to view one customer's elements and policies at a time.

**Certificate**

Electronic identification of a user or device. Certificates prove the user or device is who/what they claim to be. This is done through using public/private key pairs and digital signatures. Certificates are used in StoneGate for authenticating communications between the system components and for [Virtual Private Network \(VPN\)](#) authentication. Digital certificates are granted and verified by a [Certificate Authority \(CA\)](#), such as the internal CA included in the Management Server.

**Certificate Authority (CA)**

A trusted third-party organization or company that issues digital certificates, used to create digital signatures and public-private key pairs. The role of the CA in this process is to guarantee that the individual granted the unique certificate is, in fact, who he or she claims to be.

**Challenge/Response**

An authentication technique whereby a server sends an unpredictable challenge to the user, who computes a response using some form of authentication token, which can be an authenticator, or pre-shared keys used to encrypt random data.

**Checksum**

A one-way function applied to a file to produce a unique “fingerprint” of the file for later reference. File tampering can then be discovered by verifying the checksum value in the future.

**CIS**

See [Content Inspection Server \(CIS\)](#) (page 198).

**Client**

In a client-server architecture, a client is usually an application running on a computer or a workstation that uses services provided by a [Server](#).

## **Client Protection Certificate Authority**

Contains the credentials that the engine uses to sign replacement server-side certificates the engine creates and presents to clients when inspecting the clients' HTTPS connections with external servers. Also see [Server Protection Credentials](#) (page 215).

## **Client-to-Gateway VPN**

A [Virtual Private Network \(VPN\)](#) between a software client and a [Security Gateway \(SGW\)](#). Allows connecting mobile and home office workers safely to corporate resources using a secure (authenticated and encrypted) connection through insecure networks.

## **Cluster**

A group of devices, or nodes, that share a given work load. In StoneGate, you can cluster Firewalls and Sensors to share the load and provide redundancy, allowing, for example, scheduled maintenance that takes one node out of service without interrupting services to the users.

## **Cluster Mode**

Determines if all members of a cluster participate to traffic processing at all times ([Balancing Mode](#)) or if other members remain inactive until a traffic-processing member stops processing traffic ([Standby Mode](#)).

## **Cluster Virtual IP Address (CVI)**

An IP and MAC address shared by all nodes in a cluster, which are used by every node in a cluster for communication. These interfaces give the cluster a single identity on the network, reducing the complexity of routing and network design. CVIs handle the traffic directed to the firewall for inspection in firewall clusters.

## **Combined Sensor-Analyzer**

- 1) StoneGate IPS device that has both [Sensor](#) and [Analyzer](#) engines running simultaneously on the same hardware.
- 2) The [Network Element](#) that represents a Combined Sensor-Analyzer device in the Management Center.

## **Connection Tracking**

The set of data maintained for a connection. Used for relating incoming packets to existing connections. Connection tracking information also includes information to necessary for [NAT \(Network Address Translation\)](#), [Load Balanced Routing](#) and [Protocol Agents](#). May also contain accounting information.

## **Contact Address**

The IP address that is needed to contact a device performing a function in the StoneGate Management Center when there is [NAT \(Network Address Translation\)](#) being performed in between the two devices and thus the actual IP address assigned to the network interface cannot be used directly.

## **Content Inspection Server (CIS)**

A server that performs detailed examination of a connection's data and assists in the determination to allow or discard packets. Common examples include virus scanning or filtering of Web URLs. Also known as *content screening*.

### **Continue Action**

A policy parameter that sets default values to those used in the rule. The defaults are used in all subsequent rules except where specifically overridden until some other rule with the Continue action changes the values or the policy ends.

### **Context**

An [Element](#) that is added to a [Situation](#) to define what the Situation should match. Provides a framework for defining parameters, which are most entered as a regular expression, or through a set of fields and options that the administrators adjust.

### **Correlation Situation**

A [Situation](#) that defines the patterns that the [Analyzer](#) looks for when it examines event data produced by [Sensors](#).

### **CRL Server**

A server that maintains a Certificate Revocation List (CRL), which can be used in [Authentication](#) to check if the certificate has been cancelled.

### **Custom Alert**

An [Alert Element](#) that is defined by a StoneGate administrator, as opposed to a ready-made [Default Element](#) created by Stonesoft.

### **CVE**

A dictionary that provides common names for publicly known information security vulnerabilities and exposures and thus a standardized description for each vulnerability that links the vulnerability information of different tools and databases.

### **CVI**

See [Cluster Virtual IP Address \(CVI\)](#) (page 198).

## **D**

### **Default Element**

An [Element](#) that is present in the system at installation, or is added to the system during an upgrade or from a [Dynamic Update \(Package\)](#). Default elements cannot be modified or deleted by administrators, but they may be modified or deleted by dynamic update packages or upgrades.

### **Defragmentation**

The process by which a large block of data is broken up into smaller pieces (datagrams), so that it can be packaged and transmitted by the underlying network technology ([Fragmentation](#)). Once the smaller pieces arrive at their destination, the datagrams are reassembled into the larger block of data (defragmentation).

### **DHCP (Dynamic Host Configuration Protocol)**

A protocol for dynamically assigning IP addresses and other network information to an interface, based on BOOTP. A device on a network with no network information can broadcast a request for an IP address, subnet mask, default gateway and other information from a DHCP server on that same network. DHCP is defined in RFC 2131.

## **Diagram**

An [Element](#) that contains one or more network diagrams created using the Diagram Editor.

## **Digital Certificate**

See [Certificate](#) (page 197).

## **Discard Action**

An [Action](#) parameter that stops all connections matching to the rule without sending any notification to the connecting host. Confer to [Refuse Action](#) (page 213).

## **Dispatch Clustering**

See [Packet Dispatch](#) (page 210).

## **DMZ Network**

A DMZ (DeMilitarized Zone Network) is a network separate from both internal and external networks, and connected through a gateway. Often used for isolating bastion hosts or publicly available machines, e.g., mail and HTTP servers are typically located on a DMZ network. Sometimes also referred to as a *screened subnetwork*.

## **DNS Spoofing**

An attack method whereby the DNS name of a system is assumed by a malicious system, either by corrupting the name service cache of a victim, or by compromising a domain name server for a valid domain. The victim system is then directed to the malicious system instead of the original server.

## **Domain**

Domains are administrative boundaries that allow you to separate the configuration details and other information in the system for the purpose of limiting administrator access.

## **DoS Attack (Denial of Service)**

An attack with the objective of causing enough disruption in a computer system that its usability to legitimate users suffers. For example, an attacker may target a website so that it becomes overloaded, and slows down so much that it becomes unusable for people wishing to view it.

## **DSCP (DiffServ Code Point)**

The Differentiated Services (DiffServ) Type of Service ([ToS Flag](#)) field added to packets in the network.

## **DSCP Mark**

A field in [QoS Policy](#) rules that writes a particular [DSCP \(DiffServ Code Point\)](#) marker to the packets, if the QoS Policy is applied on the interface the packets use to exit the firewall.

## **DSCP Match**

A field in [QoS Policy](#) rules that assigns the [QoS Class](#) specified in the rule to incoming packets that have a specific [DSCP \(DiffServ Code Point\)](#) marker set, if the QoS Policy is applied on the interface the packets use to enter of the firewall.

## **Dynamic IP address**

An IP address that is assigned by using the [DHCP \(Dynamic Host Configuration Protocol\)](#).

## Dynamic NAT

A way to translate network addresses, where for each original address, a translated address and possibly a port are selected dynamically from a predefined pool.

## Dynamic Update (Package)

A file supplied by Stonesoft that provides updates to [Default Elements](#) and policies, most importantly to the [Situation](#) and [Vulnerability](#) information that is used for traffic inspection in [Inspection Rules](#).

## E

### Element

A StoneGate object representing the equipment in your physical networks or some area or concept of configuration. Elements may, for example, represent a single device such as a server, a range of IP addresses, or some configuration aid in the Management Center, such as a Category. Also see [Network Element](#) (page 210).

### Encryption

Used for data security, encryption translates any data into a secret code. Public-key encryption and symmetric encryption are the main types of encryption. Decrypting ciphertext (encrypted data) into plaintext requires access to a secret key.

### Encryption Domain

Networks that are defined to be behind a certain VPN gateway in a [Virtual Private Network \(VPN\)](#) configuration.

### Encryption Key

The data that is used to convert plaintext to ciphertext. In symmetric algorithms, the same key is the decryption key as well. In public key algorithms, a different, but related key is used to convert the ciphertext back into plaintext.

### Encryption Policy

Settings that define which encryption and authentication methods are used to establish a [Virtual Private Network \(VPN\)](#).

### Enforce VPN Action

A firewall [Action](#) parameter that directs traffic from protected local networks into the [Virtual Private Network \(VPN\)](#) tunnel and allows traffic that arrives through a VPN, and drops any non-VPN traffic from external networks to the local network that matches the rule. See also [Apply VPN Action](#) (page 195).

### Engine

The device that runs firewall, sensor, or analyzer software; a standard server or a StoneGate appliance. Represented by a [Node](#) in the Management Client.

### Ethernet Rules

A set of rules in the [IPS Policy](#) that define which Ethernet traffic is allowed or discarded by a [Sensor](#) in [Transparent Access Control Mode](#).

## Expression

An [Element](#) that can be used to accurately define a whole complex set of elements by including and excluding elements using logical expressions.

## External Gateway

Any [Security Gateway \(SGW\)](#) that is managed by a different [Management Server](#) than the one on which the [Virtual Private Network \(VPN\)](#) is being configured.

# F

## Filter

A description of log fields and their values combined together using operators for the purpose of sorting in or out log, alert, and audit entries. Used, for example, to filter out logs from the display in the [Logs View](#) so that those entries that are interesting at the moment can be found more easily.

## Firewall

1) A [Network Element](#) that represents the firewall device in the Management Center. Either a [Single Firewall](#) or a [Firewall Cluster](#).

2) The device running the StoneGate firewall software.

## Firewall Cluster

A Group of two or more [Firewall Engines](#) that work together as if they were a single unit.

## Firewall Engine

The device that runs firewall software; a standard server or a StoneGate appliance Represented by the [Firewall Node](#) in the Management Client.

## Firewall Node

An individual [Firewall Engine](#) in the Management Client, representing a device that runs firewall software as part of a [Firewall Cluster](#) or a [Single Firewall](#).

## Forward Action

A firewall [Action](#) parameter that directs traffic from protected local networks or from a [Virtual Private Network \(VPN\)](#) tunnel into another VPN tunnel.

## Fragmentation

The process by which a large block of data is broken up into smaller pieces (datagrams), so that it can be packaged and transmitted by the underlying network technology (fragmentation). Once the smaller pieces arrive at their destination, the datagrams are reassembled into the larger block of data ([Defragmentation](#)).

# G

## Gateway

A device that provides VPN access for other devices.

## Gateway Certificate

A [Certificate](#) used for authenticating a [Gateway](#) to other Gateways and [VPN Clients](#) in a VPN.

## Gateway Profile

An element that defines a set of VPN-related capabilities that a VPN [Gateway](#) supports.

## Gateway Settings

An element that contains general settings for StoneGate firewall/VPN engines related to VPN performance.

## Gateway-to-Gateway VPN

In StoneGate, a [Virtual Private Network \(VPN\)](#) element which is set up so that the VPN is established between two gateway devices providing connectivity to networks behind the gateways.

## Geolocation

Elements that define a geographical location of an IP address. Used for illustrating networks and network traffic on a map and other informative purposes in the [Management Client](#).

## Granted Element

An [Element](#) or [Security Policy](#) that an administrator has been given permission to edit and install when their [Administrator Role](#) would otherwise prevent them from doing so.

## Group

A [Network Element](#) that includes other elements and represents them all at once in policies and other parts of the configuration. For example, you can define a Group of several WWW-servers, and then use the Group element in policies when you need to make a rule that concerns all of the WWW-servers.

# H

## Hardware

A category of [Tags](#) for [Situations](#). Meant for grouping Situations that detect known vulnerabilities in applications that run on a particular hardware platform.

## Hash Signature

A cryptography-related concept that refers to a digital fingerprint associated with a given message and computed with one-way algorithms. Hash signatures are used to secure the integrity of encrypted data, ensuring that no tampering has taken place during transmission. See also [Client-to-Gateway VPN](#) (page 198), and [SHA-1](#) (page 215).

## Heartbeat

A protocol that the nodes of a [Firewall Cluster](#) or [Sensor Cluster](#) use to monitor each other and for other tasks that are needed for collaboration between each [Node](#).

## High Availability

The implementation of clustering technology, hot standby technology, or general redundancy in a system to increase the availability of an application, service, or network beyond what a single system is capable of providing. Increased availability is achieved by eliminating all single points of failure, with clustering technology providing the highest level of availability.

## Host

1) A [Network Element](#) that represents any single device that has an IP address.

2) Any device connected to a TCP/IP network, including the Internet, with one or more IP addresses. Hosts are distinguishable from gateways or routers, in that they do not forward, or route, packets to other networks.

### **Hot Standby**

A solution where one node handles the work load with the support of a back-up node, which takes over connections in case of failure in the first node.

### **Hybrid Authentication**

A system using both [Asymmetric Encryption](#) and [Symmetric Encryption](#). Asymmetric techniques are used for key management and digital signatures. The symmetric algorithms are used to encrypt the bulk of data with reduced strain on resources.

### **IKE Proposal**

The suggested encryption algorithms, authentication methods, hash algorithms, and Diffie-Hellman information in the Security Association (SA) component of an IPsec VPN. The initiator of an IPsec tunnel can make multiple proposals, but the responder only sends one proposal in return. See also [Internet Key Exchange \(IKE\)](#) (page 205) and [Security Association \(SA\)](#) (page 214).

### **Incident Case**

An [Element](#) that administrators can use to gather together all the data, actions, system configuration information, and files related to a specific incident of suspicious activity.

### **Incident History**

A collection of all the logs and audit entries that track actions performed in a particular [Incident Case](#) window.

### **Info Panel**

A tab in [Management Client](#) windows that shows information on the selected element or other object. The Info view shows, for example, the nodes belonging to a selected cluster.

### **Inherited Rule**

A rule either hidden or shown on a grey background in a [Security Policy](#) or [Template Policy](#) which has been added in a template higher up in the policy hierarchy so that it has been passed down to the security policy or template policy. Inherited rules are enforced just as any other rules, but they can be edited only in the template where the rule was originally added.

### **Inline Interface**

A Sensor interface that combines together two physical interfaces, enabling the traffic to be routed through as if the Sensor was an extension of the network cable, but allowing the Sensor to actively monitor packets and connections and stop them according to its [Actions](#) and [Inspection Rules](#).

## **Insert Point**

The place in a [Security Policy](#) or [Template Policy](#) where new rules can be inserted when no rules have been inserted in that place yet (shown as a green row) or the place in a template policy where rules can be inserted in inheriting policies and template policies (shown as an orange row).

## **Inspection Rule**

The definitions on the Inspection tab in a Firewall or IPS policy that defines options for deeper inspection and reactions to traffic accepted in [Actions](#). The matching in Inspection rules is done based on matching information provided by [Situation](#) elements. Confer to [Action](#) (page 193).

## **Internal Gateway**

A StoneGate [Firewall](#)/VPN engine that are managed by the same [Management Server](#) on which the [Virtual Private Network \(VPN\)](#) is being configured.

## **Internal Network**

The networks and network resources that StoneGate is protecting. In StoneGate, there is no concept of internal and external networks in the system.

## **Internet Key Exchange (IKE)**

A protocol defined by the [IPsec \(IP Security\)](#) standard for securely exchanging key-related information between connecting hosts when establishing a [Virtual Private Network \(VPN\)](#).

## **Internet Service Provider (ISP)**

A company that provides Internet connectivity to subscribers.

## **Intrusion Detection System (IDS)**

A system that monitors network traffic for determining, and making administrators aware of data security exploits or attempts by providing logs or other network information. Confer to [Intrusion Prevention System \(IPS\)](#).

## **Intrusion Prevention System (IPS)**

A system that monitors network traffic (like an [Intrusion Detection System \(IDS\)](#)) and has the capability of actively stopping traffic if it is deemed malicious or otherwise unwanted.

## **IP Address Bound License**

A [License](#) file for the engines that includes the information on the IP address of the component it licenses. If you need to change the IP address of the component, you must request an IP address change at the Stonesoft Licensing website. On engines, an alternative to a [Management Bound License](#) (page 208).

## **IPComp (IP Payload Compression Protocol)**

A protocol used to reduce the size of IP datagrams. Increases the overall communication performance between a pair of communicating gateways by compressing the datagrams, provided the nodes have sufficient computation power, and the communication is over slow or congested links. IPComp is defined in RFC 2393.

### **IP Splicing (or Hijacking)**

An attack performed by intercepting and using an active, established session. Often occurs after the authentication phase of the connection is complete, giving the attacker the permissions of the original, authenticated user. Encryption at the session or network layer is typically the best defense from such an attack.

### **IP Spoofing**

A technique used to obtain unauthorized access to computers by sending connection requests with tampered headers, simulating a trusted source.

### **IPsec (IP Security)**

A set of protocols supporting secure exchange of packets. Used for the implementation of [Virtual Private Network \(VPN\)](#) solutions when high performance and/or support for a wide variety of protocols are needed. IPsec provides transport and tunnel encryption modes. IPsec is defined in RFC 2401.

### **IPsec Proposal**

Suggested encryption algorithms, hash algorithms, authentication methods, etc. to be used for an [IPsec \(IP Security\)](#) tunnel. See also [IKE Proposal](#) (page 204).

### **IPS Policy**

The [Security Policy](#) for IPS Sensors and Analyzers containing the [Action](#) and [Inspection Rule](#) definitions that determine how traffic is inspected and how the system reacts when a match is found.

### **IPv4 Access Rule**

A row in a Firewall or IPS policy that defines how one type of IPv4 connection is handled by providing matching criteria based on the source, destination, and protocol information. Confer to [IPv6 Access Rule](#) (page 206).

### **IPv6 Access Rule**

A row in an IPS policy that defines how one type of IPv6 connection is handled by providing matching criteria based on the source, destination, and protocol information. Confer to [Action](#) (page 193).

### **ISAKMP (Internet Security Association Key Management Protocol)**

An open-ended encoding protocol necessary for IKE negotiation when establishing Security Associations. See also [Security Association \(SA\)](#) (page 214).

### **ISP (Internet Service Provider)**

See [Internet Service Provider \(ISP\)](#) (page 205).

## **J**

### **Journal**

A tool in the [Incident Case](#) window that allows administrators to create a permanent record of their actions while investigating an incident.

## Jump Action

A [Security Policy](#) parameter that directs the inspection to a [Sub-Policy](#), against which connections matching the rule with the Jump action are checked. Can be used to speed up traffic processing, as connections that do not match the Jump rules are not checked against rules in the sub-policies.

## L

### License

Files you import to the system to tell the [Management Server](#) that the components you have installed have been legally purchased. You generate the Licenses at the Stonesoft Licensing website and import them to the Management Server using the Management Client.

### Lifetime

The interval at which the IPsec participants should begin to negotiate a replacement [Security Association \(SA\)](#) (soft lifetime) or the interval at which the current SA for an IPsec tunnel is no longer valid (hard lifetime) in a [Virtual Private Network \(VPN\)](#).

### Load Balancing

A process for distributing work evenly across multiple, available devices to avoid overwhelming any single system.

### Load Balancing Filter

A software component that determines which network connections should be handled by a particular node in a cluster, based on address information, current load, performance of individual machines, and other factors.

### Load Balanced Routing

A method for choosing routes to destinations based on determining the fastest response time through multiple gateways. The application of [Multi-Link](#) technology to determine which network link provides the best round trip time.

### Load Sharing

The distribution of work between multiple devices. Similar to [Load Balancing](#), but not as effective, since the techniques used do not ensure an *equal* distribution of the work load. Load sharing is typically a static method of distributing a load, whereas load balancing is often a dynamic method.

### Location

An [Element](#) that groups together system components that are on the same side of a device doing [NAT \(Network Address Translation\)](#). Used to define [Contact Addresses](#) for components that communicate within the StoneGate Management Center.

### Logging Options

A selection available in all rules in policies that determines if and how a record is created when the rule matches.

### Logging Profile

Defines how the Log Server converts [Syslog](#) data received from a particular type of third-party component into StoneGate log entries.

## Log Server

A component of the [Management Center](#) responsible for storing and managing log (and alert) data.

## Log Spool

A temporary storage area in a firewall node for log data before it is sent to a [Log Server](#).

## Logical Interface

An IPS [Element](#) used in the IPS policies to represent one or more physical network interfaces as defined in the [Sensor](#) properties.

## Logs View

A tool that allows browsing logs, alerts, audit data, and connections each in an adapted version of the same user interface.

# M

## Main Mode

An IKE negotiation mode, which exchanges six messages between the end-points of an IPsec tunnel to complete the negotiation of authentication and keys for a [Virtual Private Network \(VPN\)](#). Optionally, Perfect Forward Secrecy (PFS) can be applied to protect further negotiations. See also [Aggressive Mode](#) (page 193) and [Perfect Forward Secrecy \(PFS\)](#) (page 211).

## Malware

Malicious software designed to infiltrate or damage a computer system.

## Management Bound License

A [License](#) file for StoneGate engines that is based on information on the Management Server's [Proof of License \(POL\)](#) code. An alternative to an [IP Address Bound License](#) (page 205).

## Management Center

The system consisting of a [Management Server](#), one or more [Log Servers](#) and none to several Web Portal Servers that is used to manage the [Firewall Engines](#), and to store and manage traffic and system related data.

## Management Client

A graphical user interface component that provides the tools for configuring, managing, and monitoring the firewalls, sensors, analyzers, and other components in the StoneGate system. The Management Client connects to the [Management Server](#) to provide these services based on the [Administrator](#) information that you use when launching the Management Client software.

## Management Network

The network used for communication between firewalls, Management Servers, Log Servers and the Management Client.

## Management Server

A system component that stores all information about the configurations of all firewalls, sensors, analyzers, and other StoneGate components in the system, monitors their state, and provides access for Management Clients when administrators want to change the configurations or command the engines. The most important component in the system.

### **Maximum Transmission Unit (MTU)**

The largest physical size of a datagram that can be transmitted over a network without fragmentation. Often expressed in bytes, it can apply to frames, packets, cells or other media, depending on the underlying topology.

### **Modem Interface**

A firewall interface that defines the settings of a 3G modem that provides a wireless outbound link for a [Single Firewall](#).

### **Monitored Element**

A StoneGate server or engine component that is actively polled by the Management Server, so that administrators can keep track of whether it is working or not. All StoneGate system components are monitored by default.

### **Monitoring Agent**

A software component that can be installed on servers in a [Server Pool](#) to monitor the server's operation for the purposes of [Traffic Management](#).

### **Multicast**

A technique by which a set of packets are sent to a group of machines sharing a common address. Unlike broadcast, it does not include all machines, and unlike unicast, it usually has more than one member of the group.

### **Multi-Layer Inspection**

A hybrid firewall technology that incorporates the best elements of application level and network level firewalls, with additional technology to enable the secure handling of many connection types.

### **Multi-Link**

Patented Stonesoft technology to connect one site to another, or to the Internet, using more than one network link. Applications of Multi-Link technology include inbound and outbound traffic management for unencrypted as well as VPN traffic. See also [Outbound Multi-link](#) (page 210).

## **N**

### **NAT (Network Address Translation)**

A mechanism for assigning local networks a set of IP addresses for internal traffic and another for external traffic. It increases security by hiding internal IP addresses and enables hosts with "invalid" (non-routable) addresses to communicate on the Internet.

### **NDI**

See [Node Dedicated IP Address \(NDI\)](#) (page 210).

### **NetLink**

An [Element](#) used for implementing routing of StoneGate's [Multi-Link](#) features. NetLinks can represent any IP-based network links (such as ISP routers, xDSL, leased lines, dial-up modems). NetLinks are combined together into an [Outbound Multi-link](#).

## Network Element

1) All [Elements](#) that represent one or more components that have an IP address, that is, a general category ('Network Elements') for those elements that represent physical devices and networks in StoneGate.

2) The Network Element called 'Network' that represents a (sub)network of computers. Used for rules and configurations that are common for all hosts in a specific (sub)network.

## Network Scan

A stage of an attack in which the attacker scans the target to enumerate or map the directly-connected network(s).

## Node

The representation of an individual firewall, sensor or analyzer [Engine](#) in the Management Client.

## Node Dedicated IP Address (NDI)

A unique IP address for each machine. The only interface type for single firewalls. Not used for operative traffic in firewall clusters and sensors. Firewall clusters use a second type of interface, [Cluster Virtual IP Address \(CVI\)](#), for operative traffic. Sensors have two types of interfaces for traffic inspection, the [Capture Interface](#) and the [Inline Interface](#).

## O

## Operating System

A category of [Tags](#) for [Situations](#). Meant for grouping Situations that detect known vulnerabilities in a particular operating system or applications that run on that operating system.

## Outbound Multi-link

An [Element](#) used for combining [NetLinks](#) for load balancing outbound traffic. The NetLinks included in a Outbound Multi-link element are frequently tested to determine which is the fastest NetLink for new outbound connections.

## P

## Packet

A segment of data sent across a network that includes a header with information necessary for the transmission, such as the source and destination IP addresses.

## Packet Dispatch

A [Cluster Virtual IP Address \(CVI\)](#) mode in which only one node in the cluster receives packets. This dispatcher node then forwards the packets to the correct node according to [Load Balancing](#), as well as handles traffic as a normal node. The recommended cluster mode for new installations.

## Packet Filtering

A method of controlling access to a network, or set of networks, by examining packets for source and destination address information, and permitting those packets to pass, or halting them based on defined rules.

## Packet Sniffer

See [Sniffer](#) (page 216).

## **Perfect Forward Secrecy (PFS)**

A property of IKE transactions that enhances the secrecy of keys, but requires additional processing overhead. PFS ensures that the distribution of key-related information remains independent from previously existing key material. See also [Internet Key Exchange \(IKE\)](#) (page 205).

## **Permission Level**

The general level of rights that an [Administrator](#) has. Permissions are customized with [Administrator Roles](#) and [Granted Elements](#).

## **Permit Action**

An [Inspection Rule](#) action that stops the inspection of all traffic that matches to the rule that uses the Permit action and lets the traffic continue to its destination.

## **Phishing**

A [Social Engineering](#) attack in which a malicious e-mail or web page attempts to solicit sensitive information such as usernames, passwords, and credit card details by masquerading as coming from a trustworthy entity.

## **Player**

Any element or IP address that was involved in an incident that is being investigated using the [Incident Case](#) element.

## **Policy**

A container for the Access rules, Inspection rules, and NAT rules.

## **Policy Routing**

User-defined routing based on information that is not normally used in routing, such as the source IP address, port information, or service type.

## **Policy Snapshot**

A record of policy configuration that shows the configuration in the form that it was installed or refreshed, including the rules of the policy, the elements included and their properties, as well as the time when the policy was uploaded, and which administrator performed the upload. Helps in keeping track of configuration changes.

## **Port Address Translation (PAT)**

A process, similar to [NAT \(Network Address Translation\)](#), where the source or destination port is changed to a different port. PAT is often used to disguise, or masquerade a service in place of another. See also [NAT \(Network Address Translation\)](#) (page 209).

## **Pre-shared Key**

A string of characters that is stored on two (or more) systems and that is used for authenticating or encrypting communications between the systems.

## **Primary Management Server**

The Management Server that is actively used for configuring the system in a system that has at least one [Secondary Management Server](#).

## Probing Profile

Settings that define how a Log Server monitors third-party components.

## Proof of License (POL)

A code used for verifying the legitimate purchase of StoneGate software products. Used for generating [License](#) files at the Stonesoft website.

## Proof of Serial Number (POS)

Identification code attached to StoneGate appliances.

## Protocol

An element that is used inside [Service](#) elements to specify a [Protocol Agent](#) for the Firewall [Actions](#) and the protocol of the traffic for the [Inspection Rules](#).

## Protocol Agent

A process on the firewalls that assists the engine in handling a particular [Protocol](#). Protocol Agents ensure that related connections for a service are properly grouped and evaluated by the firewall engine, as well as assisting the engine with content filtering or network address translation tasks. See also [Connection Tracking](#) (page 198).

## Protocol Tag

A type for [Protocol](#) elements that are only used to define the protocol of traffic for inspection against the inspection rules. Confer to [Protocol Agent](#).

## Proxy ARP

Proxy ARP option on a device that does routing means that the device relays broadcast messages between two hosts that are in separate physical networks, but still have IP addresses from the same network. This proxy is needed for the ARP requests, as broadcast messages are not normally relayed from one network to another. See also [Address Resolution Protocol \(ARP\)](#) (page 193).

## Pruning

Deleting log entries according to [Filters](#) either as the logs arrive on the Log Server or before they are stored (after displaying them in the current view in the Logs view).

## Public-key Cryptography

A cryptographic system that uses a pair of keys: a public key, used to encrypt a message, and a private (secret) key that can decrypt the message. This is also called asymmetric encryption.

## Q

### QoS Class

An [Element](#) that works as a link between a rule in a [QoS Policy](#) and one or more firewall [Actions](#). The traffic allowed in the access rule is assigned the QoS Class defined for the rule, and the QoS class is used as the matching criteria for applying QoS Policy rules.

### QoS Policy

A set of rules for [Bandwidth Management](#) and [Traffic Prioritization](#) for traffic that has a particular [QoS Class](#), or rules for assigning QoS Classes based on a [DSCP Match](#) found in the traffic.

**Refragmentation**

A technique to fragment outbound packets from the firewall in the same manner in which they were fragmented when the firewall received them. See also [Virtual Defragmentation](#) (page 220).

**Refuse Action**

An [Action](#) parameter that blocks the packet that matches the rule and sends an error message to the originator of the packet. Confer to [Discard Action](#) (page 200).

**Regular Expression**

A string that describes a set of strings. Used in many text editors and utilities to search for text patterns and, for example, replace them with some other string. In StoneGate, regular expressions are used, for example, for defining patterns in traffic that you want a certain [Situation](#) to match when you give the Situation a [Context](#) that calls for a Regular Expression.

**Related Connection**

A connection that has a relationship to another connection defined by a [Service](#). For example, the FTP protocol defines a relationship between a control connection, and one or more data connections at the application level. The firewall may be required to allow a connection that would otherwise be discarded, if it is related to an already allowed connection.

**Request for Comments (RFC)**

A document that outlines a proposed standard for a protocol. RFCs define how the protocol should function, and are developed by working groups of the Internet Engineering Task Force (IETF), and reviewed and approved by the Internet Engineering Steering Group (IESG). See <http://www.rfc-editor.org/>.

**Retained License**

A [Management Bound License](#) that has been used to install a policy on an engine and has then been unbound without relicensing or deleting the engine the license was bound to. Retained licenses cannot be bound to any engine before the engine the license was previously bound to is deleted or has a new policy refresh with a valid license.

**RFC**

See [Request for Comments \(RFC\)](#).

**Rootkit**

A set of tools that intruders to computer systems use for hiding their presence and the traces of their actions.

**Route**

The set of routers or gateways a packet travels through in order to reach its destination. In TCP/IP networks, individual packets for a connection may travel through different routes to reach the destination host.

**Router**

A [Network Element](#) representing a physical router in your network. Most often used to indicate next-hop routers in the Routing view and in Network Diagrams.

## Routing Table

A database maintained on every router and gateway with information on paths to different networks. In StoneGate, the routing table is represented graphically in the Routing view.

## Rule

An expression used to define the eventual outcome of packets arriving at the firewall, which match certain conditions (e.g., source and destination address, protocol, user).

## Rules Tree

The main configuration tool for adjusting [Inspection Rule](#) definitions.

## S

### SA (Security Association)

See [Security Association \(SA\)](#) (page 214).

### Scan

See [Network Scan](#) (page 210).

### Secondary IP address

An IP address used for identifying an element with multiple addresses as a source or destination of traffic, defined in addition to a primary IP address.

### Secondary Log Server

A [Log Server](#) defined as a backup channel for components that primarily send their logs to some other Log Server.

### Secondary Management Server

A redundant [Management Server](#) that replicates the configuration data from the [Primary Management Server](#) under normal conditions so that the services offered by the Management Server can be used without interruption if components fail or are otherwise unavailable.

### Secret Key Cryptography

See [Symmetric Encryption](#) (page 217).

### Security Association (SA)

A unidirectional, logical connection established for securing [Virtual Private Network \(VPN\)](#) communications between two sites. A security association records the information required by one site to support one direction of the IPsec connection whether inbound or outbound. It uses transport mode for communications between two hosts and tunnel mode for communication between security gateways. See also [Authentication Header \(AH\)](#) (page 195).

### Security Gateway (SGW)

A device, typically a firewall, that performs encryption/decryption on [Virtual Private Network \(VPN\)](#) packets sent between [Sites](#) through untrusted networks.

### Security Parameter Index (SPI)

A value used by AH and ESP protocols to help the firewall cluster select the security association that will process an incoming packet. See also [Authentication Header \(AH\)](#) (page 195).

## Security Policy

The set of templates, policies, and sub-policies together or individually that define what traffic is acceptable and what traffic is unwanted. Policies are defined using the Management Client, stored on the Management Server and installed on firewalls, sensors, and analyzers, which then use their installed version of the policies to determine the appropriate action to take regarding packets in the network.

## Sensor

A StoneGate IPS component that captures all the traffic from a physical network link, inspects it according to its policy, and if installed inline, selects which connections are allowed to continue. Provides data for the Analyzer (see [Analyzer](#) (page 194)).

## Sensor Cluster

Group of two or more IPS Sensor nodes that work together as if they were a single Sensor.

## Server

1) A [Network Element](#) representing a physical server in your network. Generally, server elements are only defined to configure a specific server for use with the [Management Center](#) (such as a RADIUS server used for authenticating administrators), but generic Servers can be used in Network Diagrams instead of [Host](#) elements to better illustrate the network layout.

2) In a client-server architecture, a computer that is dedicated for running services used by [Client](#) computers. The services may include, for example, file storage, e-mail, or web pages.

## Server Pool

A [Network Element](#) representing a group of [Servers](#). Used for inbound traffic management.

## Server Protection Credentials

An element that stores the private key and certificate of an internal HTTPS server. The private key and certificate allow the engine to present itself as the server to clients so that the engine can decrypt and inspect incoming HTTPS traffic. Also see [Client Protection Certificate Authority](#) (page 198).

## Service

An [Element](#) that is used for matching traffic to an application level protocol, for example, FTP, HTTP or SMTP. The TCP and UDP Services also determine the port number. Service elements are used in policies to make the rule match only a particular protocol, to enable [Protocol Agents](#), and select traffic to be matched against [Inspection Rules](#).

## Session Stealing

See [IP Splicing \(or Hijacking\)](#) (page 206).

## SHA-1

A cryptographic algorithm used for hash functions. It generates a 160-bit signature from an input of any length. See also [Hash Signature](#) (page 203).

## Single Firewall

A firewall that has only one [Firewall Engine](#).

## **Single Point of Failure**

The point at which the failure of a single device or component of a system will lead to either the failure of the entire system, or the inability to use services normally provided by that system. Redundant systems, using high availability technologies, eliminate single points of failure.

## **Site**

A set of resources protected by StoneGate.

## **Situation**

- 1) An [Element](#) that identifies and describes detected events in the traffic or in the operation of the system. Situations contain the [Context](#) information, i.e., a pattern that the system is to look for in the inspected traffic.
- 2) An [Inspection Rule](#) cell where Situation elements are inserted.

## **Situation Type**

A category of [Tags](#) for [Situations](#). Meant for indicating what kind of events the associated Situations detect (for example, Attacks, Suspicious Traffic).

## **Sniffer**

A device or program that captures data traveling over a network. Sniffers are often used for troubleshooting network problems, as they can show the packet flow taking place. They can also be used maliciously to steal data off a network.

## **SNMP Agent**

A software component that sends SNMP traps when specific events are encountered.

## **Social Engineering**

An attack involving trickery or deception for the purpose of manipulating people into performing actions or divulging confidential information.

## **SPI (Security Parameter Index)**

See [Security Parameter Index \(SPI\)](#) (page 214).

## **SSH (Secure Shell)**

A program to log into another computer over a network, to execute commands in a remote machine, and to move files from one machine to another. It provides strong authentication and secure communications over insecure channels. Often used as a replacement for insecure programs such as `telnet` or `rsh`. In StoneGate, SSH can be used for remotely accessing the engine command line.

## **SSL VPN**

A VPN technology that utilizes SSL encryption to secure users' remote access to specific applications. Allow authenticated users to establish secure connections to a limited number of specific internal services through a standard web browser ("clientless" access) or through a client application that allows a wider range of services.

## **Standby Management Server**

See [Secondary Management Server](#) (page 214).

## **Standby Mode**

An operating state of a StoneGate cluster that keeps one node online and the rest in standby, so that [State Synchronization](#) is done, but node does not process the traffic. If the online node is taken offline or fails, one of the standby nodes takes over the existing connections.

## **State Synchronization**

The communication of connection tracking information between several firewall nodes in a cluster. Can be either a full synchronization, where all connection tracking information is transferred to the other nodes of a cluster, or an incremental synchronization, where only the information on connections changed after the last synchronization are transferred. See also [Connection Tracking](#) (page 198).

## **Static IP address**

IP address that is typed in by a user or an administrator, and which does not change without their action.

## **Static NAT**

[NAT \(Network Address Translation\)](#) where for each original address, there is a single, predefined translated address.

## **Static Routing**

A form of routing that has permanent routes between networks programmed into every [Routing Table](#).

## **Sub-Policy**

A set of rules that are separated from the main policy, based on some common category, such as the service or the destination IP address. In this way, related rules can be grouped together to make the entire policy easier to understand. Because subrules are only processed if the general rule in the main policy matches, the overall processing time is improved.

## **Subtunnel**

The actual tunnels that are combined logically within a multi-route VPN tunnel in a StoneGate [Multi-Link](#) environment. They represent all possible routes that connect the end-points of the security gateways between which a [Virtual Private Network \(VPN\)](#) is formed. The individual subtunnels may connect the two gateways through different network links.

## **Symmetric Encryption**

An Encryption mechanism that uses the same shared secret key for encrypting and decrypting messages. It is often referred to as symmetric bulk encryption since it processes large amounts of data rather quickly. Also known as conventional or secret key cryptography. There are two main types of symmetric encryption algorithms, bulk and stream encryption (also known as block ciphers and stream ciphers). Common symmetric algorithms are DES and 3DES. See also [Asymmetric Encryption](#) (page 195).

## **Syslog**

A standard protocol for exchanging logs between network components. Defined in RFC 5424.

## **System Summary**

A panel in the System Status view that provides a general summary view of the current status of the monitored elements according to the component type.

**Tag**

An [Element](#) for organizing [Situations](#). Tags can also be used in [Inspection Rules](#), in the Situation cell, to represent all Situations marked with that Tag.

**Takeover Period**

The time interval during which the active nodes in a firewall or sensor cluster collaborate to redistribute the work load of a failed node.

**Task**

An [Element](#) that allows you to schedule commands to run automatically at a convenient time.

**Template Policy**

A combination of rules and [Insert Points](#), which is used as a basis when creating policies or other template policies. Policies and template policies created from a particular template policy then inherit all the rules from that template policy and any of the template policies higher up in the inheritance hierarchy. The [Inherited Rules](#) cannot be edited within the inheriting policy. Used, for example, by high-privilege Administrators to restrict changes administrators with a lower [Administrator Role](#) can make to rules.

**Temporary Filter**

A log filter that is created from details of entries in the [Logs View](#) or the Connections view, and which is only available until the view is closed.

**Terminate Action**

An [Inspection Rule](#) parameter that stops or attempts to stop the connection matching to the rule according to the [Action Option](#) selected and the whether the [Engine](#) where the rule matching occurs is capable of stopping the connection.

**Tester**

A tool that can automatically run tests on StoneGate engines to check system or network operation and take action based on the results of those tests.

**Timeline**

A tool in the [Logs View](#) that allows you to select and change the time range for the logs that are displayed.

**ToS Flag**

A data field in IP packet headers that provides a number representing the type of the service the packet is a part of. The ToS flag is used for [Traffic Prioritization](#) and is also know as [DSCP \(DiffServ Code Point\)](#).

**Traffic Handler**

The set of [Network Elements](#) used for inbound and outbound traffic management. Includes [NetLinks](#), [Outbound Multi-links](#), and [Server Pools](#).

## Traffic Management

The control, definition, and management of how packets or connections should flow through firewalls, routers, network links, VPNs or other gateway objects, based on load balancing, clusters, availability of links and more.

## Traffic Prioritization

The process of assigning traffic a priority value, which is used to determine the order in which queued packets are sent forward, overriding the standard first-come-first-served operation of network devices. Used for assuring Quality of Service (QoS) for time-critical connections. Can be used together with [Bandwidth Management](#) or on its own. See also [DSCP \(DiffServ Code Point\)](#) (page 200), [QoS Class](#) (page 212) and [QoS Policy](#) (page 212).

## Transparent Access Control Mode

A [Sensor](#) configuration in which the Sensor examines Ethernet traffic according to the [Ethernet Rules](#).

## Transparent Proxy

A technique whereby a connection is routed to a proxy server, which then establishes a second connection to the original destination host, but the entire transaction takes place without notifying the user, or requiring the user to perform any additional actions.

## Transport Protocol

Any protocol that communicates and functions on the transport layer of the TCP/IP protocol stack. These protocols function above the network layer, and are usually responsible for error correction, quality of service, and other characteristics not handled by the network layer. TCP, UDP, and IPsec are common examples of transport protocols.

## Tunneling

A technology that enables one network to send its data through another, perhaps dissimilar, network. Tunneling works by encapsulating, or packaging, a network protocol within packets carried by the second network.

## U

### Use IPsec VPN Action

A firewall [Action](#) parameter that directs traffic matching to the rule to a VPN. Can be either an [Apply VPN Action](#) or an [Enforce VPN Action](#).

### UDP Tracking

Information maintained by the firewall engines to group together UDP requests and replies, handling them as a single virtual connection. See also [Virtual Connection Tracking](#) (page 220).

### User

An [Element](#) that defines an end-user in your network. Used for defining [Authentication](#) with or without [Client-to-Gateway VPN](#) access. Confer to [Administrator](#) (page 193).

### User Response

Defines additional notification actions for rule matches, such as redirecting access to a forbidden URL to a page on an internal web server instead.

## **UTM (Unified Threat Management)**

A device that combines different types of traffic filtering in one physical appliance. The features offered in a UTM device vary greatly from vendor to vendor. The StoneGate UTM comprises a firewall, deep packet inspection (IDS), and antivirus.

## **V**

### **Virtual Adapter**

A component of the StoneGate VPN Client, or a third-party VPN client, that allows using a second, [Virtual IP address](#) for [Virtual Private Network \(VPN\)](#) traffic. Shown as a network adapter in the operating system.

### **Virtual Connection Tracking**

A superset of UDP tracking, ICMP tracking, etc. A technology that is used by the firewall engines for connectionless network protocols like UDP and ICMP. The firewall engines keep track of virtual connections by grouping together packets that are related, based on information in the packet headers. See also [Related Connection](#) (page 213).

### **Virtual Defragmentation**

A procedure in which incoming packet fragments are collected. The packet is defragmented for processing by the firewall engine, and refragmented before it is transmitted again. See also [Fragmentation](#) (page 202).

### **Virtual IP address**

A second IP address that is given to a [VPN Client](#) that has a [Virtual Adapter](#) enabled, and that is connecting to a security gateway using [Client-to-Gateway VPN](#). A virtual IP address enables the use of certain services that require the client to have an IP address belonging to a specific address range, while enabling it to retain its primary IP address for maintaining other connections. The Virtual IP address for StoneGate VPN Clients is always assigned by [DHCP \(Dynamic Host Configuration Protocol\)](#).

### **Virtual Local Area Network (VLAN)**

A local area network which is defined through software in a switch or other networking device, rather than by the more traditional hardware division.

### **Virtual Private Network (VPN)**

Refers to a confidential connection that is established through unsecured networks by the means of authentication, encryption, and integrity checking. The two major VPN technologies are [IPsec \(IP Security\)](#), which is better suited when a wide variety of network services and large traffic volumes are involved, and [SSL VPN](#), which is used to provide access to a limited number of services to individual users without client-side device configuration.

### **VPN Client**

Software that can be used to establish a [Virtual Private Network \(VPN\)](#) with a VPN gateway device to securely access remote resources over insecure networks.

### **VPN Profile**

An element that defines the [IPsec \(IP Security\)](#)-related settings for one or more VPNs.

**Vulnerability**

An IPS element that contains information on a publicly known flaw that affects security of some system. Vulnerabilities are attached to [Situations](#) to provide you more information on what has happened when the Situation matches.

**W****Web Filtering**

A feature that compares the URLs that users attempt to open to a list of URLs to prevent users from intentionally or accidentally accessing most web sites that are objectionable or potentially harmful.

**Web Portal**

Browser-based service that allows users to view logs, [Policy Snapshots](#), and reports.

**Whitelisting**

The process of exempting specific traffic from being blocked by [Blacklisting](#) or [Web Filtering](#).



# INDEX

## A

- access control lists, 54, 55–56
- acknowledging alerts, 93
- action field, 172
- active alerts, 93
- address range element, 40
- administration configuration view, 34
- administrator accounts, 53
  - domains, 57, 62
  - RADIUS authentication, 58
  - using, 57–58
- administrator roles, 54, 55, 56
- administrators, 53
  - access control lists, 54, 55–56
  - administrator roles, 54, 55, 56
  - authenticating, 56
  - log colors, 58
  - password policy, 59
  - RADIUS authentication, 58
  - web portal user elements, 57–58
- alert chains, 90, 91
- alert channels, 93, 94
- alert entries, 82, 90, 93
- alert entry fields, 152
- alert escalation, 89–97
  - custom scripts for, 94–95
  - examples, 96
- alert event traces, 93
- alert policies, 90–92, 94
- alert trace entry fields, 152
- alias element, 40
- aliases, 143
  - system aliases, 144
  - user aliases, system-defined, 144
- architecture, 15
- audit entries, 82
- audit entry fields, 153
- audit entry types, 182
- authentication
  - administrators, 56
  - web portal users, 58
- authentication server, 17

## B

- backup servers, 18
- browser-based interface, 16

## C

- categories, 67–69
  - category filters, 68
- centralized management, 17
- certificate authority, internal, 16

- combined category filters, 69
- command line tools, 125
- commands
  - engine, 135
  - log server, 126
  - management server, 126
- components of the management center, 20
- connection states, 188
- contact information, 12
- custom alerts, 91
- custom services, 41
- customer support, 12

## D

- data for reports, 101
- default services, 41
- defined operation in filters, 77
- deployment, 19–22
- disaster recovery, 18
- discard before storing filters, 83–85
- documentation available, 11
- domain name element, 40
- domains, 61–65
  - administrator permissions, 62
  - associating elements with, 63
  - creating, 62
  - examples, 64–65
  - moving elements, 63
  - shared domain, 62
  - user authentication, 63
- drill-down top rate summaries, 102

## E

- editor, 55
- elements
  - access control lists, 54
  - administration, 34
  - administrators, 54
  - associating with domains, 63
  - expressions, 46
  - firewall, 35
  - group, 40
  - host elements, 40
  - introduction to, 34
  - IPS, 37
  - monitoring, 39
  - moving across domains, 63
  - network elements, 40
  - server elements, 40
  - services, 41
  - situations, 41
  - SSL VPN gateway elements, 40

- traffic handler elements, 40
- VPN, 43
- web portal users, 54
- event field, 172
- examples
  - alert escalation, 96
  - archiving logs, 86
  - categories, 69
  - domains, 64–65
  - filters, 80
  - incident cases, 112
  - log management, 86
  - pruning logs, 86
- exporting reports, 105–107
- expressions, 40, 45–49
  - grouping, 48
  - nesting, 49
  - operands, 46
  - processing order, 48
- external LDAP
  - schema files, 192

## F

- facility field, 169
- fields in filters, 75
- filters, 73–80
  - fields, 75
  - operations, 76
  - undefined values, 77
- fingerprint of certificates, 133
- firewall configuration view, 35
- firewall element, 40
- firewall log fields, 154

## G

- group element, 40
- grouping parts of expressions, 48

## H

- hardware requirements, 12
- high availability, 18
- host element, 40

## I

- immediate discard filters, 83–85
- incident cases, 109–112
  - example, 112
  - journal, 111
  - player list, 111
  - tabs, 110
- internal certificate authority, 16
- intersections in expressions, 47
- IP address expressions, 46
- IPS configuration view, 37

- IPS log fields, 156
- IPS recording logs fields, 168

## L

- LDAP (Lightweight Directory Access Protocol)
  - schema updates, 192
- licenses, 18
- log entries, 82
- log files, 83, 85
- log management, 81–87
  - log tasks, 84
- log pruning, 83–85
- log server, 16
- log tasks, 84
- logging options, 84
- logs
  - action field values, 172
  - additional payload, 187
  - alert entry fields, 152
  - alert trace entry fields, 152
  - audit entry fields, 153
  - connection states, 188
  - event field values, 172
  - firewall log fields, 154
  - IPS log fields, 156
  - IPS recording log fields, 168
  - log field values, 148
  - non-exportable log fields, 148
  - SSL VPN log fields, 169
  - syslog entries, 187
  - VPN log messages, 177

## M

- management center components, 20
- management client, 16, 26–31
- management server, 16
- monitoring configuration view, 39
- monitoring server, see web portal server
- monitoring users, see web portal users

## N

- negations in expressions, 46
- nesting expressions, 49
- network diagrams in monitoring, 27
- network element, 40
- network elements, 40
  - address range, 40
  - alias, 40
  - domain name, 40
  - expressions, 40, 46
  - firewall, 40
  - group, 40
  - host, 40
  - IPS, 40

- network, 40
- router, 40
- server, 40
- SSL VPN gateway, 40
- traffic handlers, 40
- zones
  - element
  - zones, 40

non-exportable log fields, 148

## O

- operands in expressions, 46
- operations in filters, 76
- operator, 55
- owner, 55

## P

- parenthesis in expressions, 48
- passwords, administrator password policy, 59
- PCI reporting, 105
- post-processing reports, 106
- pre-defined aliases, 144
- predefined services, 41
- processing order of expressions, 48
- progress summaries, 102

## R

- RADIUS authentication, 58
- remote management, 17
- report designs, 100–101
- report items, 100–104
- report sections, 100–104
- report tasks, 105
- reports, 99–107
  - bar charts, 102
  - curve charts, 102
  - drill-down top rate summaries, 102
  - exporting, 105–107
  - filters, 101
  - log data, 100, 101
  - maps, 102
  - monitoring statistics, 100
  - period comparisons, 103
  - pie charts, 102
  - post-processing, 106
  - progress summaries, 102
  - report designs, 100–101
  - report files, 105–107
  - report items, 100–104
  - report sections, 100–104
  - report tasks, 105
  - summary table summaries, 102
  - summary types, 102–103
  - system information summaries, 102

- system reports, 105
- tab-delimited text files, 105–107
- tables, 102
  - top rate summaries, 102
- requirements for hardware, 12
- router element, 40

## S

- secondary servers, 18
- server element, 40
- services, 41
  - custom services, 41
- shared domain, 62
- situations, 41
- SSL VPN gateway element, 40
- SSL VPN log fields, 169
- standard services, 41
- state overview, *see* system status view
- statistics monitoring, 27
- summaries
  - drill-down top rate summaries, 102
  - progress summaries, 102
  - summary table summaries, 102
  - system information summaries, 102
  - top rate summaries, 102
- summary table summaries, 102
- support services, 12
- syslog, 187
- syslog servers, 85
- system aliases, 144
- system components, 15
- system design, overview, 15
- system information summaries, 102
- system reports, 105
- system requirements, 12
- system services, 41
- system status view, 27
- system-defined user aliases, 144

## T

- tab-delimited text report files, 105–107
- technical support, 12
- top rate summaries, 102
- traffic handler element, 40
- type field, 171
- typographical conventions, 10

## U

- undefined value policy, 77
- unions in expressions, 47
- user aliases, system-defined, 144
- user authentication, in domains, 63
- user-defined service elements, 41

## V

- viewer, 55
- VPN (virtual private network)
  - user aliases, 144
- VPN configuration view, 43
- VPNs
  - error codes, 181
  - error messages, 179
  - log messages, 177
  - notification messages, 177

## W

- web portal server, 16
- web portal users
  - authenticating, 58
  - domains, 58
  - passwords, 58

## Z

- zones element, 40

## StoneGate Guides

*Administrator's Guides* - step-by-step instructions for configuring and managing the system.

*Installation Guides* - step-by-step instructions for installing and upgrading the system.

*Reference Guides* - system and feature descriptions with overviews to configuration tasks.

*User's Guides* - step-by-step instructions for end-users.

For more documentation, visit  
[www.stonesoft.com/support/](http://www.stonesoft.com/support/)

### **Stonesoft Corporation**

Itälahdenkatu 22 A  
FI-00210 Helsinki  
Finland

Tel. +358 9 476 711  
Fax +358 9 4767 1349

# STONESOFT

Secure Information Flow

### **Stonesoft Inc.**

1050 Crown Pointe Parkway  
Suite 900  
Atlanta, GA 30338  
USA

Tel. +1 770 668 1125  
Fax +1 770 668 1131